



# SERVICE PARTS LIST

BULLETIN NO.  
54-24-2800

SPECIFY CATALOG NO. AND SERIAL NO. WHEN ORDERING PARTS		REVISED BULLETIN	DATE
<b>28 VOLT 1/2" HAMMER-DRILL</b>			Aug. 2012
CATALOG NO.	<b>0726-20</b>	STARTING SERIAL NO.	<b>C26A</b>
		WIRING INSTRUCTION <b>SEE REVERSE SIDE</b>	

**EXAMPLE:**  

00	0
----	---

 Component Parts (Small #) Are Included When Ordering The Assembly (Large #).

FIG.	PART NO.	DESCRIPTION OF PART	NO. REQ.
1	05-88-1500	M6 x 1.0 Pan Hd. Chuck Screw T-25	(1)
2	42-66-0755	1/2" Keyless Chuck	(1)
3	05-88-1700	M3.5 Handle Screw T-10	(7)
4	18-01-3025	Service Field	(1)
5	16-01-3060	Service Armature Assembly	(1)
6	22-22-0750	Brush Card	(1)
7	45-24-0675	High / Low Shifter	(1)
8	42-42-0800	Forward / Reverse Button	(1)
9	-----	Switch	(1)
10	-----	Terminal Block Cover	(1)

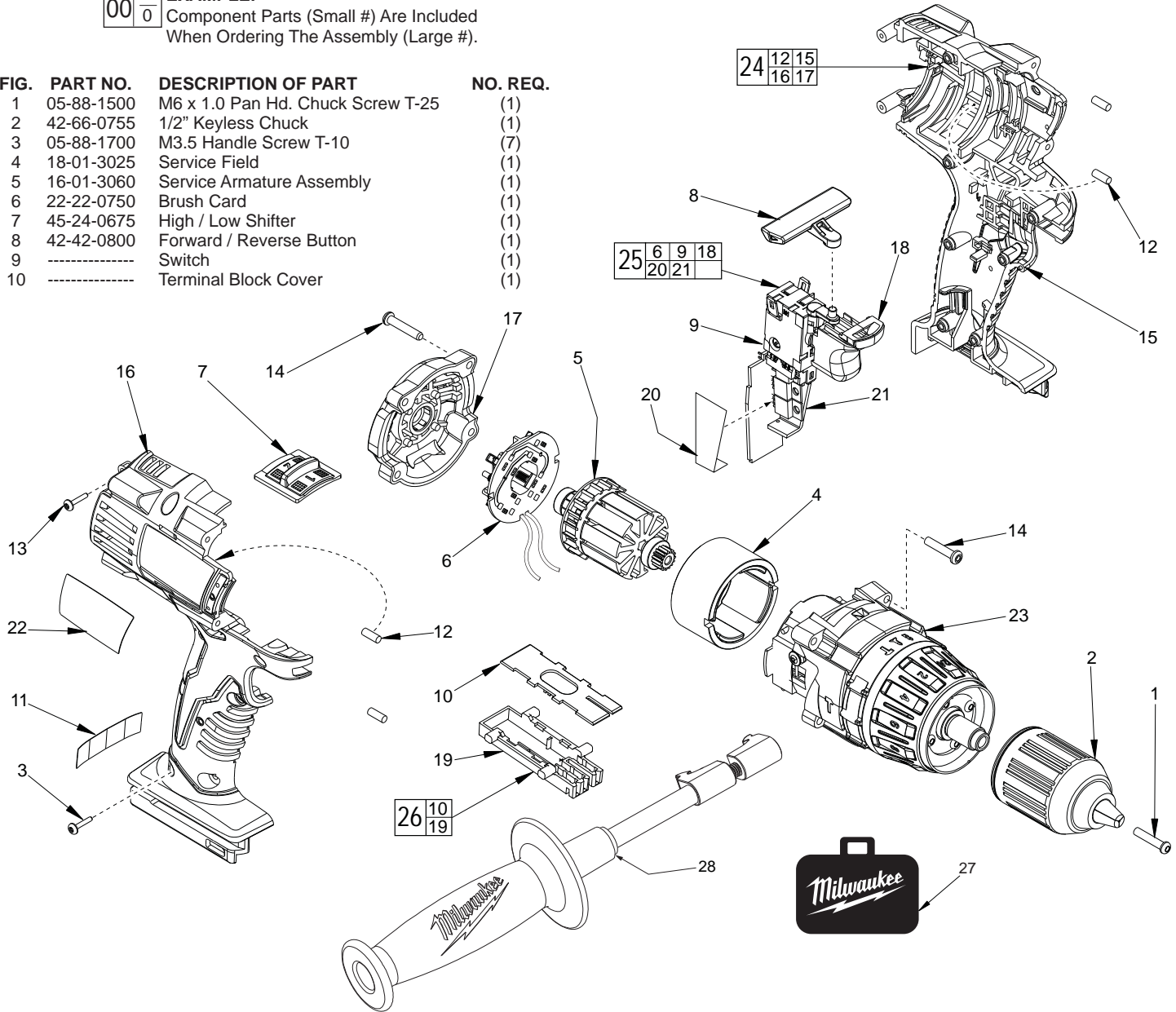
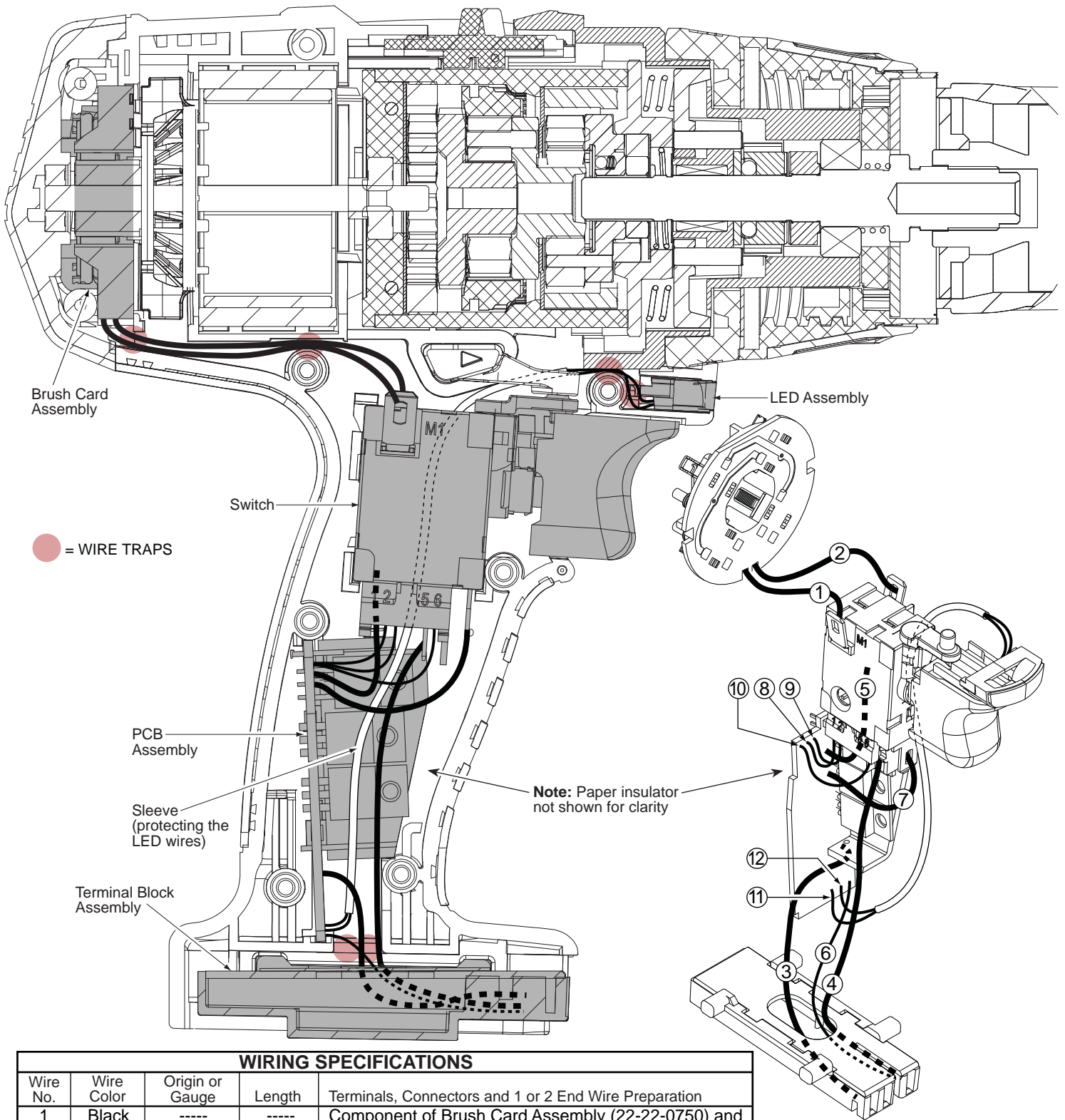

FIG.	PART NO.	DESCRIPTION OF PART	NO. REQ.
11	10-20-2760	Warning Label	(1)
12	45-30-0255	Rubber Slug	(4)
13	06-82-6350	M3 x 16mm Handle Screw T-10	(2)
14	05-88-1710	M3.5 x 22mm End Cap/Gearcase Scr T-10	(8)
15	-----	Left Handle	(1)
16	-----	Right Handle	(1)
17	42-52-0390	End Cap	(1)
18	-----	LED Assembly	(1)
19	-----	Terminal Block	(1)
20	-----	Paper Insulator	(1)
21	-----	PCB Assembly	(1)
22	12-20-2811	Service Nameplate Kit	(1)
23	14-29-0400	Service Gearcase Assembly	(1)
24	31-44-2480	Service Housing Kit	(1)
25	23-66-1335	Switch / Brush Card Assembly	(1)
26	22-56-1185	Terminal Block Assembly	(1)
27	42-55-1050	Carrying Case	(1)
28	42-62-0526	Side Handle Assembly	(1)



**WIRING SPECIFICATIONS**

Wire No.	Wire Color	Origin or Gauge	Length	Terminals, Connectors and 1 or 2 End Wire Preparation
1	Black	----	----	Component of Brush Card Assembly (22-22-0750) and the Switch/Brush Card Assembly (23-66-1335).
2	Red	----	----	
3	Black	----	----	Component of the Switch/Brush Card Assembly (23-66-1335), which contains the switch, brush card, PCB assembly, LED, terminal block, paper insulator and insulating sleeve.
4	Red	----	----	
5	White	----	----	
6	Red	----	----	
7	Blue	----	----	
8	Green	----	----	
9	Blue	----	----	
10	Black	----	----	
11	Red	----	----	
12	White	----	----	