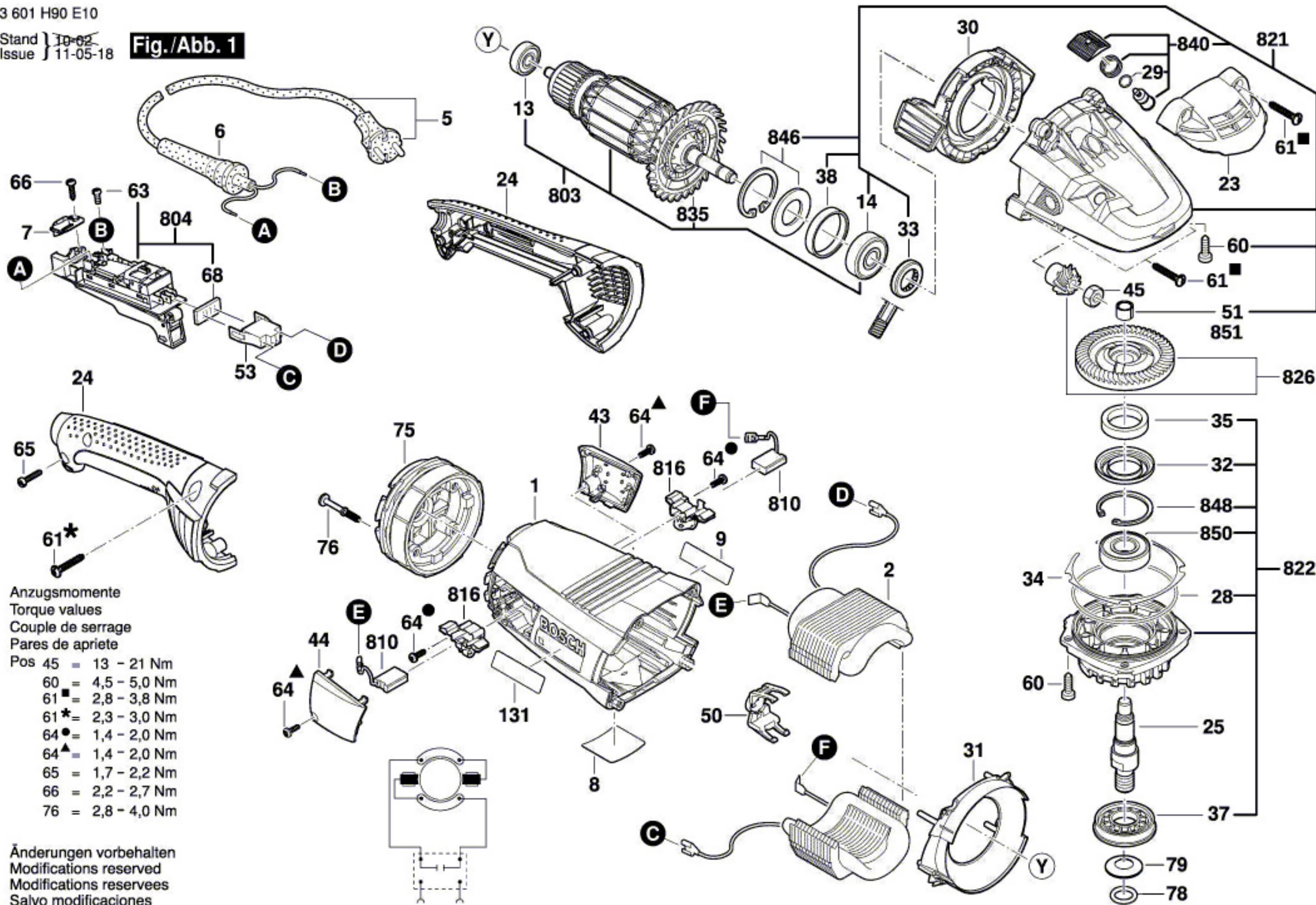

Fig./Abb. 1



- Anzugsmomente
Torque values
Couple de serrage
Pares de apriete
- | | | |
|--------|---|--------------|
| Pos 45 | = | 13 - 21 Nm |
| 60 | = | 4,5 - 5,0 Nm |
| 61 ■ | = | 2,8 - 3,8 Nm |
| 61 * | = | 2,3 - 3,0 Nm |
| 64 ● | = | 1,4 - 2,0 Nm |
| 64 ▲ | = | 1,4 - 2,0 Nm |
| 65 | = | 1,7 - 2,2 Nm |
| 66 | = | 2,2 - 2,7 Nm |
| 76 | = | 2,8 - 4,0 Nm |

Änderungen vorbehalten
Modifications reserved
Modifications reserves
Salvo modificaciones