

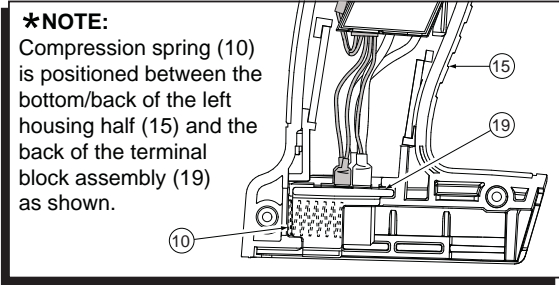

# SERVICE PARTS LIST

**BULLETIN NO.**  
54-24-2600

SPECIFY CATALOG NO. AND SERIAL NO. WHEN ORDERING PARTS		REVISED BULLETIN	DATE
<b>M18 1/2" COMPACT HAMMER-DRILL</b>			July 2012
CATALOG NO. <b>2602-20</b>	STARTING SERIAL NO. <b>C15A</b>	WIRING INSTRUCTION <b>SEE PAGE 3</b>	



**EXAMPLE:**  
Component Parts (Small #) Are Included When Ordering The Assembly (Large #).

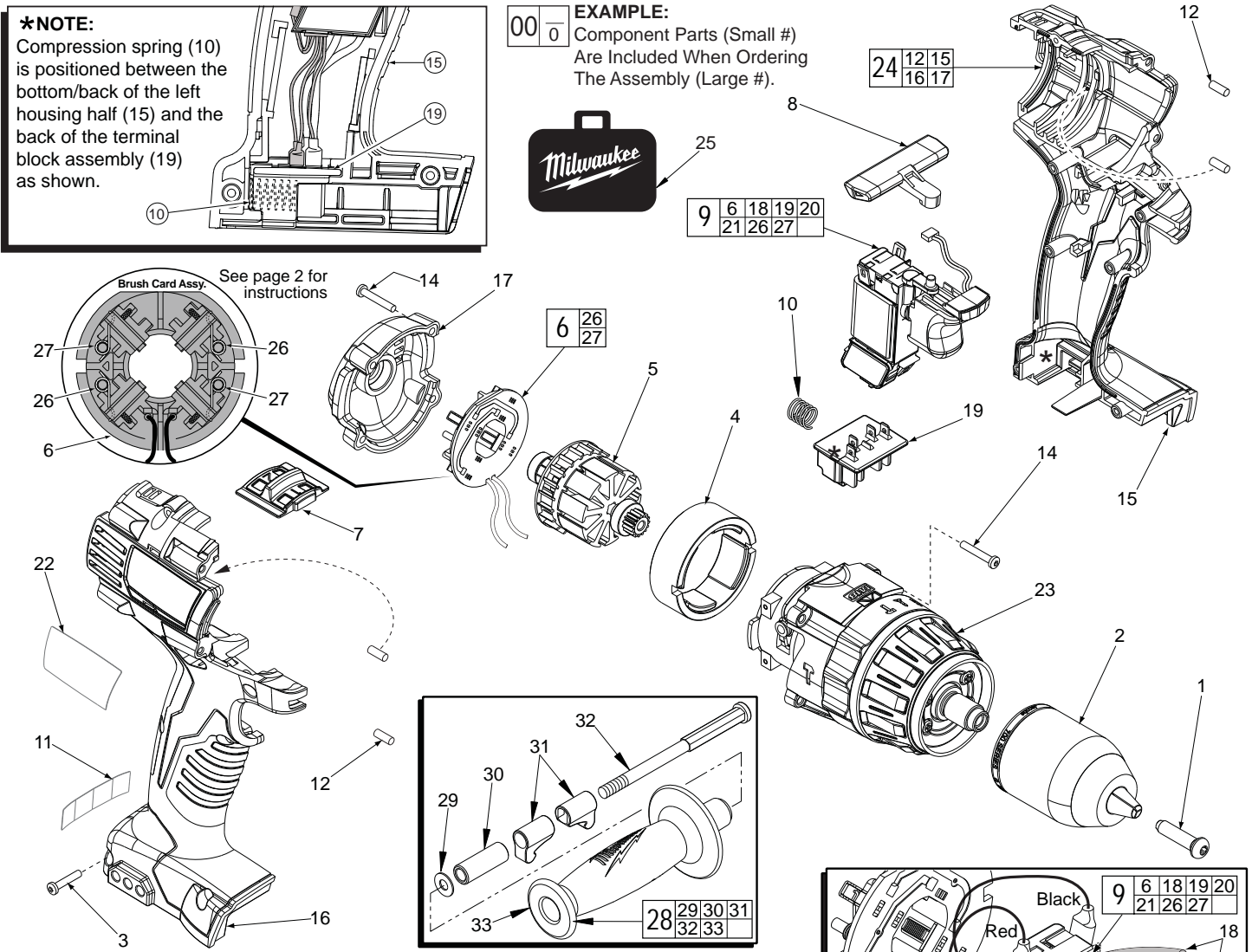

FIG.	PART NO.	DESCRIPTION OF PART	NO. REQ.
1	05-88-1500	M6 x 1.0 LH Chuck Screw w/ locking patch	(1)
2	42-66-0780	1/2" Chuck	(1)
3	05-88-0770	M3 Handle Screw T-10	(1)
4	18-01-3010	Service Field	(1)
5	16-01-3015	Service Armature Assembly	(1)
6	22-22-1550	Brush Card	(1)
7	45-24-0250	High / Low Shifter	(1)
8	42-42-0850	Forward / Reverse Button	(1)
9	23-66-1235	Switch Assembly	(1)
10	40-50-1090	Compression Spring	(1)
11	10-20-2695	Warning Label	(1)
12	45-30-0270	Rubber Slug	(4)
14	05-88-0675	M3.0 x 20mm End Cap/Gearcase Scr T-10	(8)
15	-----	Left Handle	(1)
16	-----	Right Handle	(1)
17	42-50-1060	End Cap	(1)
18	-----	LED Assembly	(1)
19	-----	Terminal Block Assembly	(1)
20	-----	Red Leadwire Assembly	(1)
21	-----	Black Leadwire Assembly	(1)
22	12-20-2602	Service Nameplate Kit	(1)
23	14-29-0375	Service Gearcase Assembly	(1)
24	31-44-2630	Service Housing Kit	(1)
25	42-55-2602	Carrying Case, Optional	(1)
26	40-50-2170	Brush Spring - Right Handed	(2)
27	40-50-2175	Brush Spring - Left Handed	(2)
28	42-62-0525	Side Handle Assembly	(1)
29	45-88-2090	Washer	(1)
30	45-22-0800	Sleeve	(1)

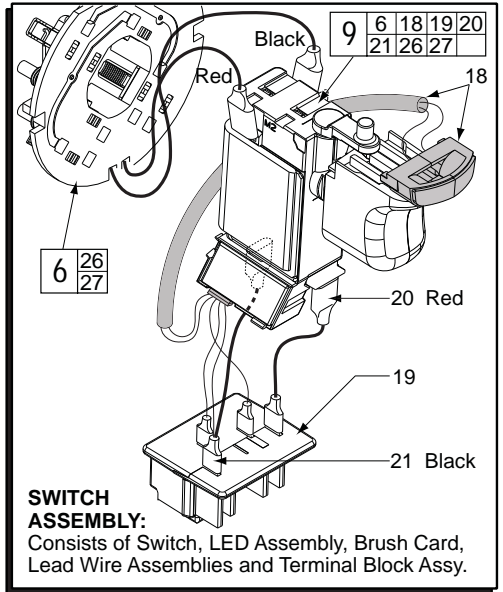
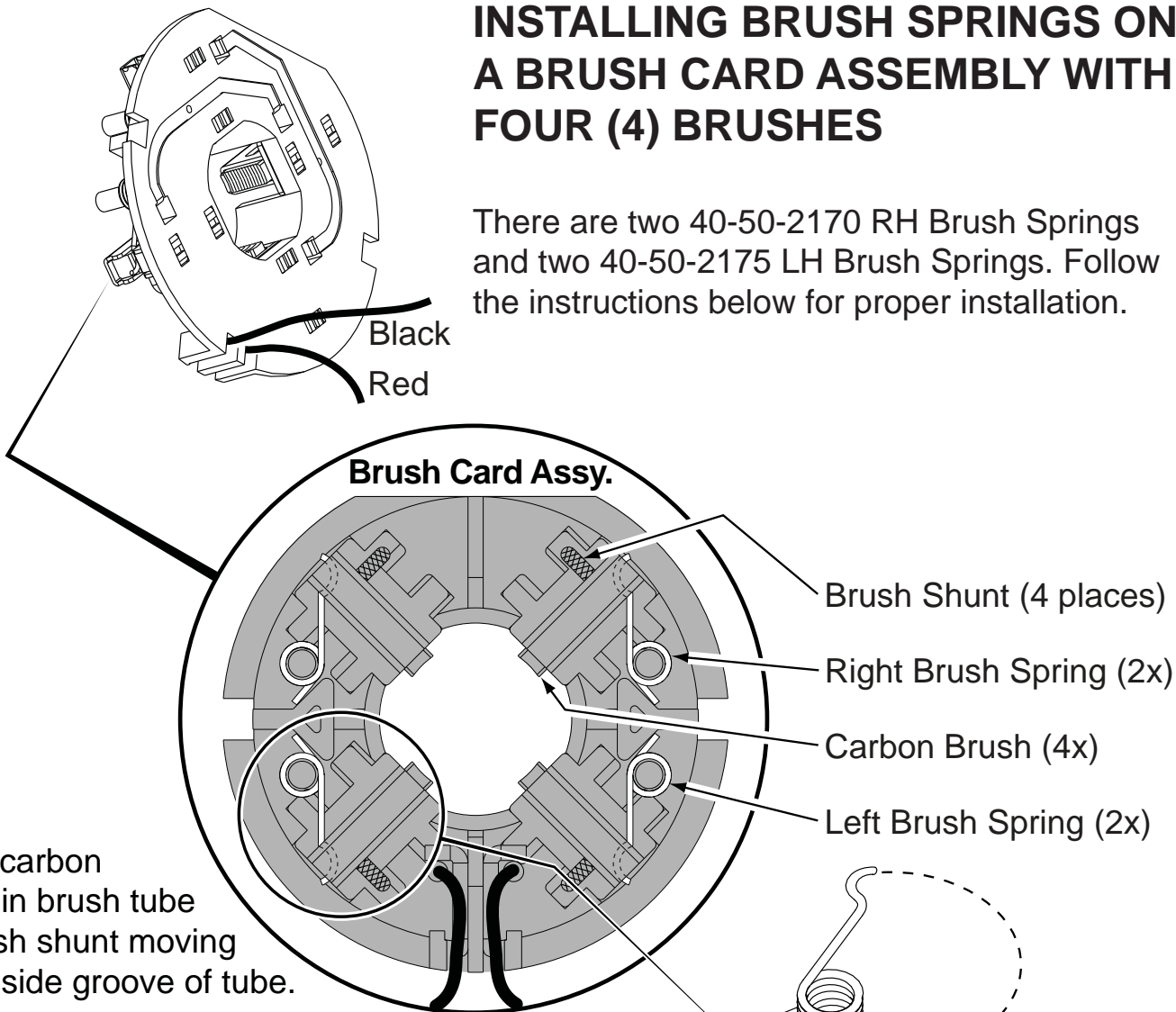

FIG.	PART NO.	DESCRIPTION OF PART	NO. REQ.
31	42-68-0925	Clamp	(2)
32	45-04-0975	Adjustment Screw	(1)
33	43-62-1375	Handle Grip	(1)

**MILWAUKEE ELECTRIC TOOL CORPORATION**  
13135 W. Lisbon Road, Brookfield, WI 53005  
Drwg. 5

# INSTALLING BRUSH SPRINGS ON A BRUSH CARD ASSEMBLY WITH FOUR (4) BRUSHES

There are two 40-50-2170 RH Brush Springs and two 40-50-2175 LH Brush Springs. Follow the instructions below for proper installation.



Be sure carbon brush is in brush tube with brush shunt moving freely in side groove of tube.

Place brush spring over post with short leg positioned downward as shown. Be sure spring is completely down with short leg trapped against 'Y' shaped wall on brush card.

While holding spring in place, bring the long leg of spring over the brush tube and through rear opening of tube. Position rounded hook of spring in groove on back of carbon brush. Be sure to check for free movement between carbon brush, brush shunt and brush spring.

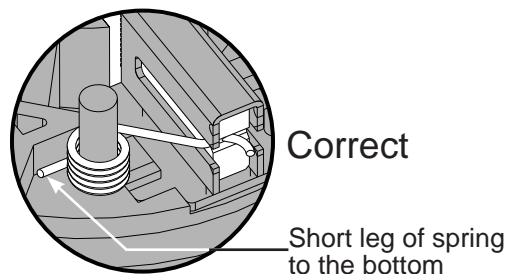
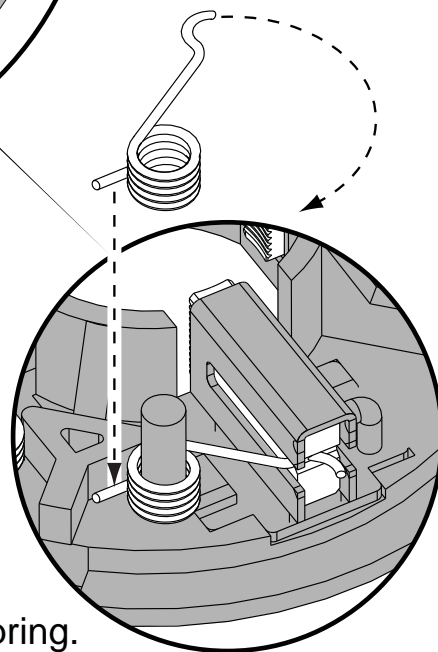

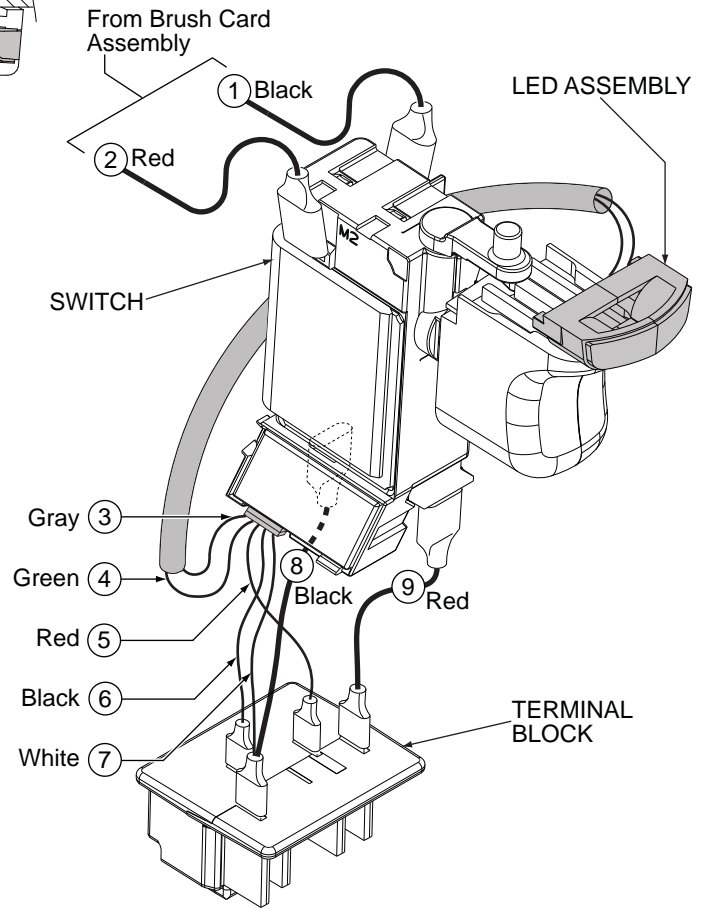
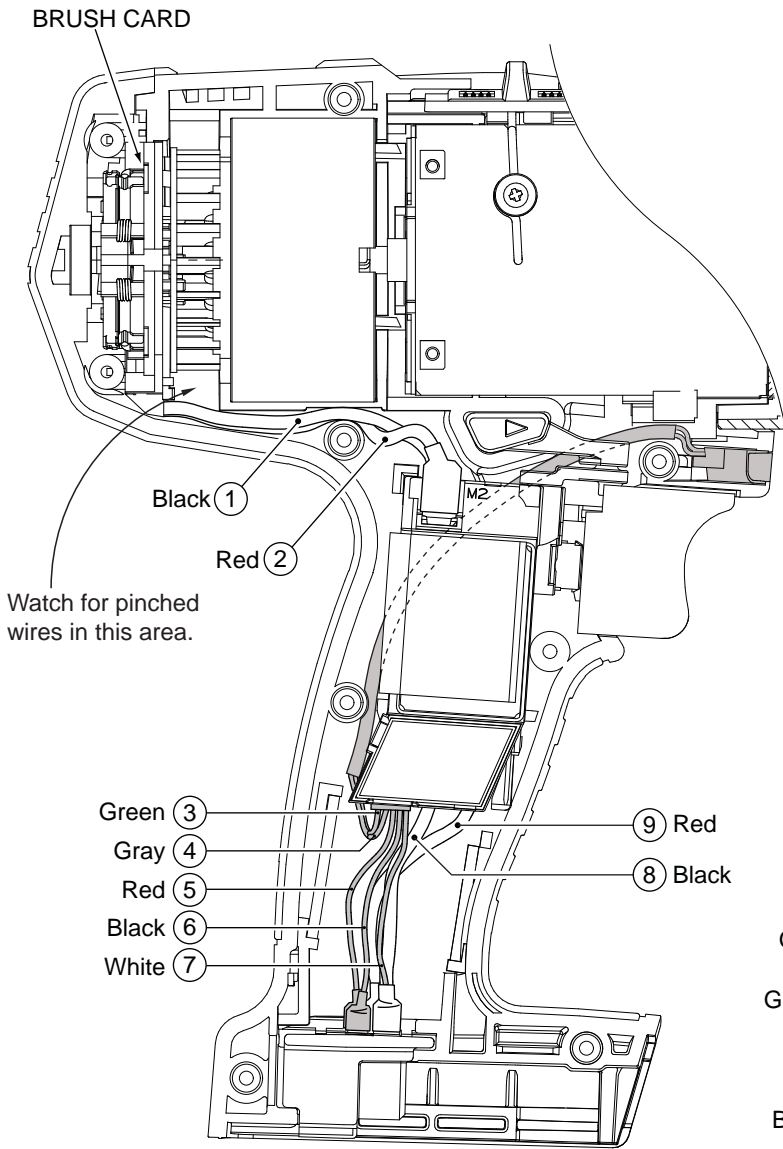

### WIRING SPECIFICATIONS

Wire No.	Wire Color	Origin or Gauge	Length	Terminals, Connectors and 1 or 2 End Wire Preparation
1	Black	-----	-----	Component of the Brush Card Assembly.
2	Red	-----	-----	Component of the Brush Card Assembly.
3	Green	-----	-----	Component of the LED Assy./Switch Assembly
4	Gray	-----	-----	Component of the LED Assy./Switch Assembly
5	Red	-----	-----	Component of the LED Assy./Switch Assembly
6	Black	-----	-----	Component of the LED Assy./Switch Assembly
7	White	-----	-----	Component of the LED Assy./Switch Assembly
8	Black	-----	-----	Component of the Switch Assembly.
9	Red	-----	-----	Component of the Switch Assembly.