



SERVICE PARTS LIST

BULLETIN NO.
54-24-2660

SPECIFY CATALOG NO. AND SERIAL NO. WHEN ORDERING PARTS		REVISED BULLETIN	DATE
M18 FUEL™ COMPACT 1/2" HAMMER-DRILL			Dec. 2012
CATALOG NO.	2604-20	STARTING SERIAL NO.	D56A
WIRING INSTRUCTION			

EXAMPLE:
Component Parts (Small #)
Are Included When Ordering
The Assembly (Large #).

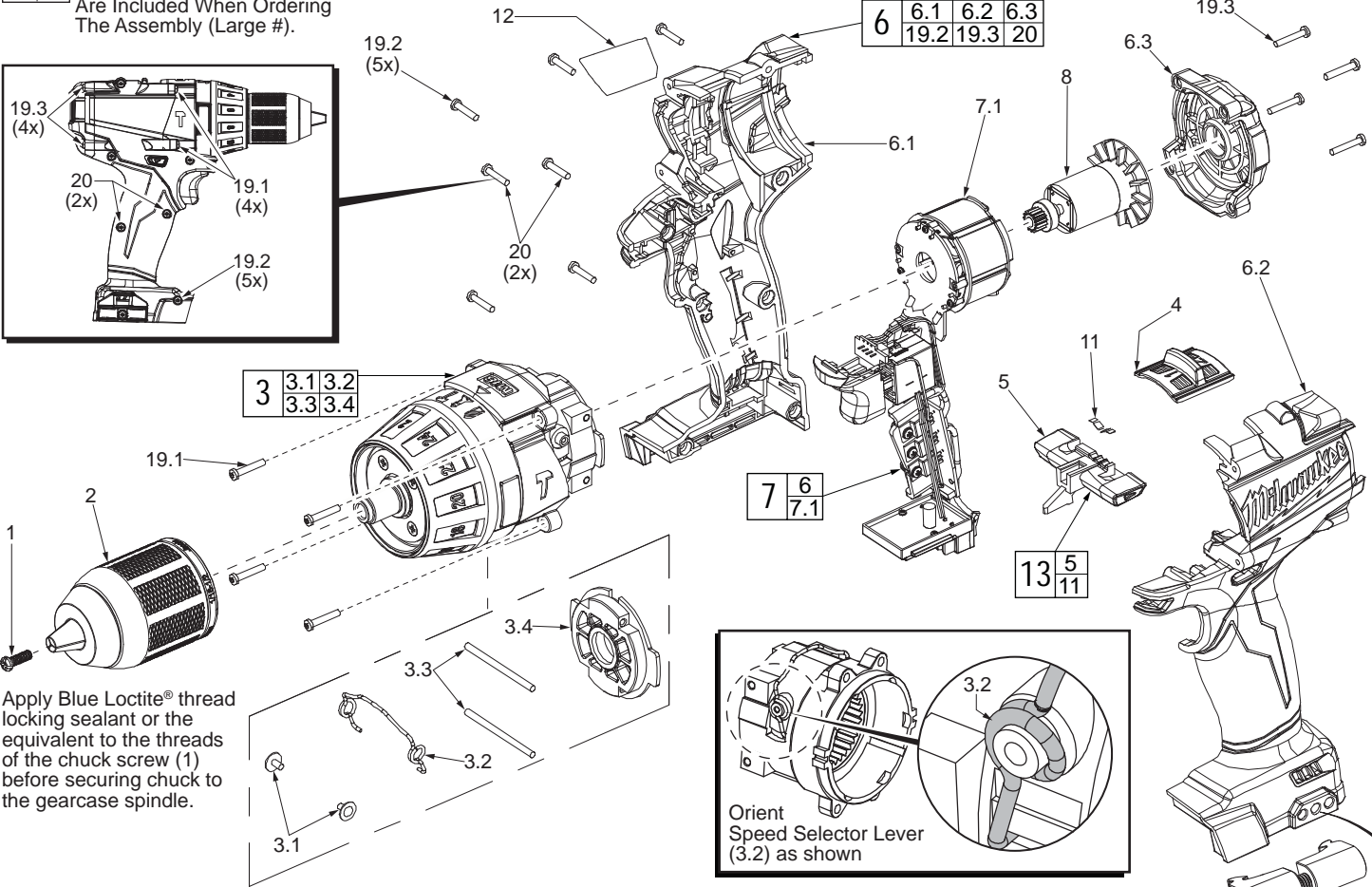
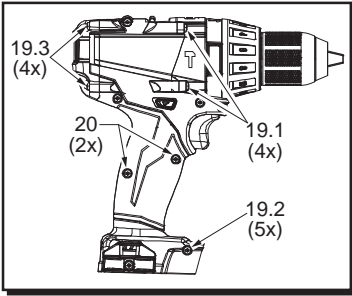

Apply Blue Loctite® thread locking sealant or the equivalent to the threads of the chuck screw (1) before securing chuck to the gearcase spindle.

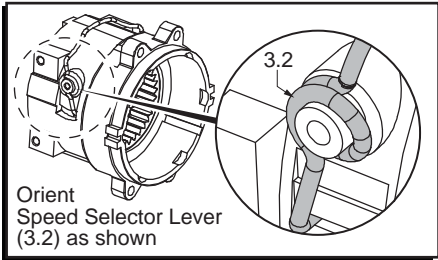
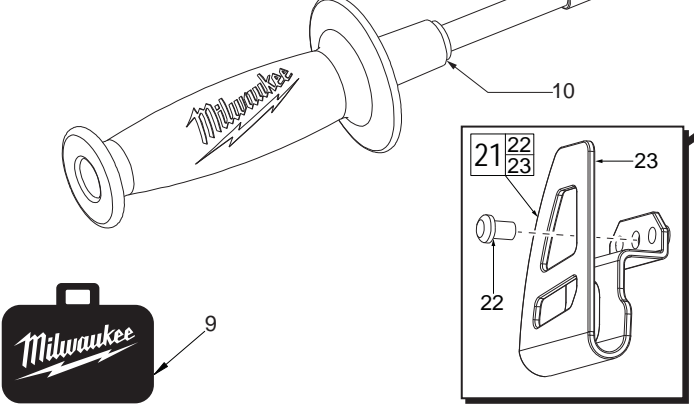

FIG.	PART NO.	DESCRIPTION OF PART	NO. REQ.
1	05-88-1500	M6 x 1.0 LH Chuck Screw w/ locking patch	(1)
2	42-66-0210	1/2" Keyless Chuck	(1)
3	14-29-2604	Gearcase Assembly	(1)
3.1	05-81-0542	M2.3 x 4.5mm ST Screw	(2)
3.2	44-10-2603	Speed Selector Lever	(1)
3.3	-----	2.3 x 34 Pin	(2)
3.4	-----	Motor Mounting Plate	(1)
4	45-24-2603	Speed Selector Button	(1)
5	42-42-2603	Forward / Reverse Shuttle	(1)
6	31-44-2603	Housing Kit	(1)
6.1	-----	Right Housing Halve	(1)
6.2	-----	Left Housing Halve	(1)
6.3	-----	Rear Cap	(1)
7	14-20-2603	Housing / Electronics Kit	(1)
7.1	-----	Motor / Switch / PCBA Assembly	(1)
8	16-07-2603	Service Armature	(1)
9	42-55-2604	Blow Molded Carrying Case	(1)
10	42-62-0525	Auxiliary Side Handle Assembly	(1)
11	40-50-1135	Shuttle Spring	(1)
12	12-20-2604	Service Nameplate	(1)
13	42-42-2604	Forward / Reverse Shuttle Kit	(1)
14	45-88-2090	Washer	(1)
15	45-22-0800	Sleeve	(1)
16	42-68-0925	Clamp	(2)
17	45-04-0975	Adjustment Screw	(1)
18	43-62-1375	Handle Grip	(1)
19.1	06-82-6350	M3 x 16mm T-10 ST Screw (Gearcase)	(4)
19.2	06-82-6350	M3 x 16mm T-10 ST Screw (Handle Halves)	(5)
19.3	06-82-6350	M3 x 16mm T-10 ST Screw (Rear Cap)	(4)
20	06-82-1080	M3 x 14mm T-10 ST Screw (Handle Halves)	(2)
21	42-70-2653	Belt Clip Assembly	(1)
22	06-82-0130	6-32 x 5/16" Pan Hd. T-15 Machine Screw	(1)
23	-----	Belt Clip	(1)



SCREW TORQUE SPECIFICATION CHART			
FIG.	PART NO.	DESCRIPTION	SEATING TORQUE (IN-LBS)
1	05-88-1500	Chuck Screw	33±2.5
3.1	05-81-0542	Speed Selector Lever Screw	3.5±1
19.1	06-82-6350	Gearcase Assembly Screw	7.0±2.5
19.2	06-82-6350	Right Housing Halve Scr (Qty. 5)	7.0±2.5
19.3	06-82-6350	Rear Cap Screw	4.0±1
20	06-82-1080	Right Housing Halve Scr (Qty. 2)	7.5±2.5

MILWAUKEE ELECTRIC TOOL CORPORATION
13135 W. Lisbon Road, Brookfield, WI 53005
Drwg. 3