

# JET<sup>®</sup>

## Operating Instructions and Parts Manual 2-Wheel Belt Grinder 3" x 79"

Model BG-379



**WALTER MEIER (Manufacturing) Inc.**

427 New Sanford Road  
LaVergne, Tennessee 37086  
Ph.: 800-274-6848  
[www.waltermeier.com](http://www.waltermeier.com)

**Part No. M-414610**  
Revision B 07/2012

Copyright © 2012 Walter Meier (Manufacturing) Inc.

# 1.0 Warranty and Service

Walter Meier (Manufacturing) Inc., warrants every product it sells. If one of our tools needs service or repair, one of our Authorized Service Centers located throughout the United States can give you quick service. In most cases, any of these Walter Meier Authorized Service Centers can authorize warranty repair, assist you in obtaining parts, or perform routine maintenance and major repair on your JET® tools. For the name of an Authorized Service Center in your area call 1-800-274-6848.

## MORE INFORMATION

Walter Meier is consistently adding new products to the line. For complete, up-to-date product information, check with your local Walter Meier distributor, or visit [waltermeier.com](http://waltermeier.com).

## WARRANTY

JET products carry a limited warranty which varies in duration based upon the product (MW = Metalworking, WW = Woodworking).

<b>90</b> DAY WARRANTY	<b>1</b> YEAR WARRANTY	Body Repair Kits Bottle Jacks Cable Pullers Cold Saws Hoists-Air Hoists-Electric Metal forming Mill/Drills Milling Machines MW Bandsaws MW Drill Presses MW Finishing Equipment MW Lathes MW Precision Vises	<b>2</b> YEAR WARRANTY	Palet Trucks Rigging Equip. Service Jacks Stackers Surface Grinders Tapping Trolleys-Air Trolleys-Electric Web Slings Winches-Electric	<b>3</b> YEAR WARRANTY	WW Benchtop Tools	<b>5</b> YEAR WARRANTY	Beam Clamps Chain Hoist- Manual Lever Hoists Pullers-JCH Models Scissor Lift Tables Screw Jacks Trolleys-Geared Trolleys-Plain Winches-Manual WW Air Filtration WW Bandsaws WW Buffers	WW Drill Presses WW Dust Collectors WW Dust Filters WW Dust Fittings WW Jointers WW Lathes WW Planers WW Sanders WW Shapers WW Tablesaws	<b>LIFE</b> LIFETIME WARRANTY	Fastening Tools Mechanics Hand Tools Striking Tools Vises (no -precision) Clamps
<i>Warranty reverts to 1 Year Warranty if woodworking (WW) products listed above are used for industrial or educational purposes.</i>											

## WHAT IS COVERED?

This warranty covers any defects in workmanship or materials subject to the exceptions stated below. Cutting tools, abrasives and other consumables are excluded from warranty coverage.

## WHO IS COVERED?

This warranty covers only the initial purchaser of the product.

## WHAT IS THE PERIOD OF COVERAGE?

The general JET warranty lasts for the time period specified in the product literature of each product.

## WHAT IS NOT COVERED?

Five Year Warranties do not cover woodworking (WW) products used for commercial, industrial or educational purposes. Woodworking products with Five Year Warranties that are used for commercial, industrial or education purposes revert to a One Year Warranty. This warranty does not cover defects due directly or indirectly to misuse, abuse, negligence or accidents, normal wear-and-tear, improper repair or alterations, or lack of maintenance.

## HOW TO GET SERVICE

The product or part must be returned for examination, postage prepaid, to a location designated by us. For the name of the location nearest you, please call 1-800-274-6848.

You must provide proof of initial purchase date and an explanation of the complaint must accompany the merchandise. If our inspection discloses a defect, we will repair or replace the product, or refund the purchase price, at our option. We will return the repaired product or replacement at our expense unless it is determined by us that there is no defect, or that the defect resulted from causes not within the scope of our warranty in which case we will, at your direction, dispose of or return the product. In the event you choose to have the product returned, you will be responsible for the shipping and handling costs of the return.

## HOW STATE LAW APPLIES

This warranty gives you specific legal rights; you may also have other rights which vary from state to state.

## LIMITATIONS ON THIS WARRANTY

WALTER MEIER (MANUFACTURING) INC., LIMITS ALL IMPLIED WARRANTIES TO THE PERIOD OF THE LIMITED WARRANTY FOR EACH PRODUCT. EXCEPT AS STATED HEREIN, ANY IMPLIED WARRANTIES OR MERCHANTABILITY AND FITNESS ARE EXCLUDED. SOME STATES DO NOT ALLOW LIMITATIONS ON HOW LONG THE IMPLIED WARRANTY LASTS, SO THE ABOVE LIMITATION MAY NOT APPLY TO YOU.

WALTER MEIER SHALL IN NO EVENT BE LIABLE FOR DEATH, INJURIES TO PERSONS OR PROPERTY, OR FOR INCIDENTAL, CONTINGENT, SPECIAL, OR CONSEQUENTIAL DAMAGES ARISING FROM THE USE OF OUR PRODUCTS. SOME STATES DO NOT ALLOW THE EXCLUSION OR LIMITATION OF INCIDENTAL OR CONSEQUENTIAL DAMAGES, SO THE ABOVE LIMITATION OR EXCLUSION MAY NOT APPLY TO YOU.

Walter Meier sells through distributors only. The specifications in Walter Meier catalogs are given as general information and are not binding. Members of Walter Meier reserve the right to effect at any time, without prior notice, those alterations to parts, fittings, and accessory equipment which they may deem necessary for any reason whatsoever. JET®-branded products are not sold in Canada by Walter Meier.

## 2.0 Table of Contents

<b>Section</b>	<b>Page</b>
1.0 Warranty and Service .....	2
2.0 Table of Contents .....	3
3.0 Safety Warnings .....	4
4.0 About this manual .....	5
5.0 Features .....	6
6.0 Specifications .....	7
7.0 Set-Up and Assembly .....	8
7.1 Floor Diagram .....	8
7.2 Unpacking and cleanup .....	8
7.3 Electrical Connections .....	8
7.4 Voltage Conversion (3PH only) .....	8
8.0 Adjustments .....	9
8.1 Belt tracking .....	9
8.2 Belt change .....	9
8.3 Belt tension adjustment .....	9
9.0 Operation .....	9
9.1 Contact grinding .....	9
9.2 Surface grinding .....	9
10.0 Maintenance .....	9
11.0 Troubleshooting .....	10
12.0 Replacement Parts .....	10
12.1.1 BG-379 Belt Grinders – Exploded View .....	11
12.1.2 BG-379 Belt Grinders – Exploded View .....	12
12.1.3 BG-379 Belt Grinders – Parts List .....	13
13.0 Electrical Connections – single phase only .....	16
13.2 Electrical Connections – 3 phase only .....	17



### 3.0 Safety Warnings

1. Read and understand the entire owner's manual before attempting assembly or operation.
2. Read and understand the warnings posted on the machine and in this manual. Failure to comply with all of these warnings may cause serious injury.
3. Replace the warning labels if they become obscured or removed.
4. This belt grinder is designed and intended for use by properly trained and experienced personnel only. If you are not familiar with the proper and safe operation of a belt grinder, do not use until proper training and knowledge have been obtained.
5. Do not use this machine for other than its intended use. If used for other purposes, Walter Meier (Manufacturing), Inc., disclaims any real or implied warranty and holds itself harmless from any injury that may result from that use.
6. Always wear approved safety glasses/face shields while using this belt grinder. (Everyday eyeglasses only have impact resistant lenses; they are not safety glasses.) Eye wear shall be impact resistant, protective safety glasses with side shields which comply with ANSI Z87.1 specifications.
7. Before operating this belt grinder, remove tie, rings, watches and other jewelry, and roll sleeves up past the elbows. Do not wear loose clothing, and confine long hair. Non-slip footwear or anti-skid floor strips are recommended. Do not wear gloves or hold the work with a rag when grinding.
8. Wear ear protectors (plugs or muffs) during extended periods of operation.
9. Some dust created by power sanding, sawing, grinding, drilling and other construction activities contains chemicals known to cause cancer, birth defects or other reproductive harm. Some examples of these chemicals are:
  - Lead from lead based paint.
  - Crystalline silica from bricks, cement and other masonry products.
  - Arsenic and chromium from chemically treated lumber.
10. Do not operate this machine while tired or under the influence of drugs, alcohol or any medication.
11. Make certain switch is in **OFF** position before connecting machine to power supply.
12. Make certain machine is properly grounded.
13. Make all machine adjustments or maintenance with machine unplugged from power source.
14. Remove adjusting keys and wrenches. Form a habit of checking to see that keys and adjusting wrenches are removed from the machine before turning it on.
15. Keep safety guards in place at all times when machine is in use. If removed for maintenance purposes, use extreme caution and replace the guards immediately after maintenance is complete.
16. The belt grinder should be secured to the floor before using.
17. Check damaged parts. Before further use of the machine, a guard or other part that is damaged should be carefully checked to determine that it will operate properly and perform its intended function. Check for alignment of moving parts, binding of moving parts, breakage of parts, mounting and any other conditions that may affect its operation. A guard or other part that is damaged should be properly repaired or replaced.
18. Provide for adequate space surrounding work area and non-glare, overhead lighting.
19. Keep the floor around the machine clean and free of scrap material, oil and grease.
20. Keep visitors a safe distance from the work area. **Keep children away.**
21. Make your workshop child proof with padlocks, master switches or by removing starter keys.
22. Give your work undivided attention. Looking around, carrying on a conversation and "horse-play" are careless acts that can result in serious injury.

23. Maintain a balanced stance at all times so that you do not fall or lean against moving parts. Do not overreach or use excessive force to perform any machine operation.
24. Use the right tool at the correct speed and feed rate. Do not force a tool or attachment to do a job for which it was not designed. The right tool will do the job better and more safely.
25. Use recommended accessories; improper accessories may be hazardous.
26. Maintain tools with care. Keep cutting tools sharp and clean for the best and safest performance. Follow instructions for lubricating and changing accessories.
27. Turn off machine and disconnect from power before cleaning. Use a brush or compressed air to remove chips or debris — do not use your hands.
28. Do not stand on the machine. Serious injury could occur if the machine tips over.

29. Never leave the machine running unattended. Turn power off and do not leave machine until it comes to a complete stop.
30. Remove loose items and unnecessary work pieces from the area before starting the machine.
31. Do not grind magnesium, as it may create a fire hazard.

**Familiarize yourself with the following safety notices used in this manual.**

**CAUTION** This means that if precautions are not heeded, it may result in minor injury and/or possible machine damage.

**WARNING** This means that if precautions are not heeded, it may result in serious or even fatal injury.

## 4.0 About this manual

This manual is provided by Walter Meier (Manufacturing) Inc. covering the safe operation and maintenance procedures for a JET Model BG-379 Belt Grinder. This manual contains instructions on installation, safety precautions, general operating procedures, maintenance instructions and parts breakdown. Your machine has been designed and constructed to provide years of trouble-free operation if used in accordance with instructions set forth in this document.

This manual is not intended to be an exhaustive guide to belt grinder operational methods, stock choice, abrasive selection, etc. Additional knowledge can be obtained from experienced users or trade journals. Whatever accepted methods are used, always make personal safety a priority.

If there are questions or comments, please contact your local supplier or Walter Meier. Walter Meier can also be reached at our web site: [www.waltermeier.com](http://www.waltermeier.com).

Retain this manual for future reference. If the machine transfers ownership, the manual should accompany it.

## 5.0 Features

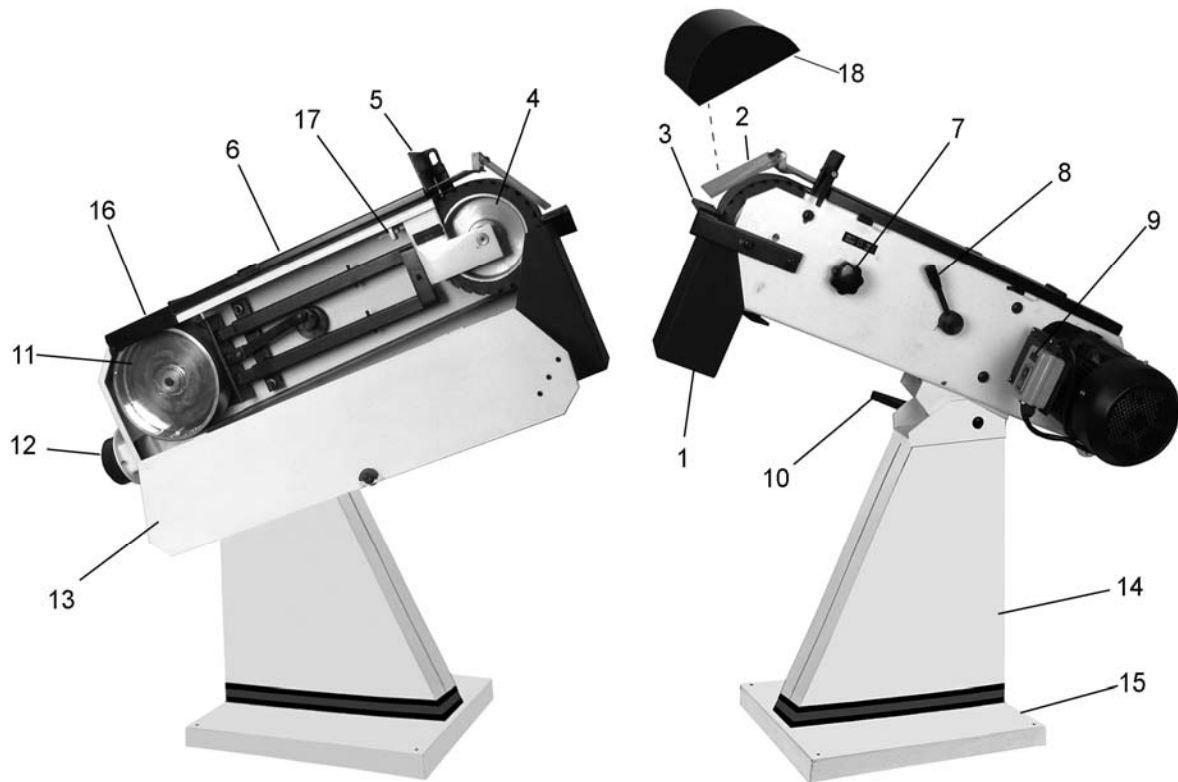

Figure 1

1. Spark trap
2. Eye shield
3. Front work support
4. Contact wheel
5. Top work support
6. Belt guard
7. Tracking adjustment knob
8. Belt tension release lever
9. Industrial switch with overload protection
10. Angle lock handle (x2)
11. Drive wheel
12. Dust port
13. Side panel
14. Pedestal
15. Base
16. Hinged guard plate
17. Tension adjustment nuts
18. Swing-away safety guard

## 6.0 Specifications

Model Number.....	BG-379-1.....	BG-379-3.....
Stock Number.....	414610.....	414615.....

### Materials:

Pedestal and Base .....	steel .....	steel .....
Belt housing .....	steel .....	steel .....
Abrasive belt provided .....	zirconium, closed coat, 80G .....	zirconium, closed coat, 80G .....
Drive wheel .....	aluminum .....	aluminum .....
Contact wheel .....	8" durometer (HRA60-65), serrated .....	8" durometer (HRA60-65), serrated .....

### Motor and Electricals:

Motor type.....	totally enclosed fan cooled, induction, capacitor start .....	totally enclosed fan cooled, induction .....
Horsepower .....	4 HP (3 kW) .....	4 HP (3 kW) .....
Phase .....	single .....	3 .....
Voltage .....	230V .....	230/460V (prewired 230V) .....
Listed FLA (full load amps) .....	34.7A .....	15.6A/8.5A .....
Starting amps.....	56.6A .....	19.2A/11.6A .....
Running amps, no load.....	15.2A .....	4.9A/2.2A .....
Start capacitor .....	400µF 250VAC .....	n/a .....
Run capacitor .....	50µF 450VAC .....	n/a .....
Cycle .....	60Hz .....	60Hz .....
Motor speed .....	3360 RPM .....	3440 RPM .....
Power transfer.....	direct drive .....	direct drive .....
Power cable length.....	300 cm (10 ft) .....	183 cm (6 ft) .....
Power plug included .....	no .....	no .....
Controls .....	industrial push button, 24V, 30A .....	industrial push button, 24V, 30A .....
Recommended circuit and breaker/fuse <sup>1</sup> .....	50A .....	30A/15A .....
Noise emission:		
Without load <sup>2</sup> .....	85 db at 93mm (3.66") distance .....	85 db at 93mm (3.66") distance .....
With load <sup>3</sup> .....	88 db at 93mm (3.66") distance .....	88 db at 93mm (3.66") distance .....

### Dimensions and Capacities:

Abrasive belt size (LxW) .....	2000 x 75 mm (79" x 3") .....	2000 x 75 mm (79" x 3") .....
Flat grinding surface .....	530 mm (21") .....	530 mm (21") .....
Working height (variable) .....	780 – 1150 mm (30-3/4" – 45-1/4") .....	780 – 1150 mm (30-3/4" – 45-1/4") .....
Belt speed.....	40 m/s (131.2 fps) .....	40 m/s (131.2 fps) .....
Contact wheel size (Dia. x W) .....	200 x 75 mm (8" x 3") .....	200 x 75 mm (8" x 3") .....
Drive wheel size (Dia. x W).....	225 x 75 mm (9" x 3") .....	225 x 75 mm (9" x 3") .....
Shipping carton (LxWxH) .....	110 x 70 x 120cm (43-1/4"x27-1/2"x47-1/4") .....	110 x 70 x 120cm (43-1/4"x27-1/2"x47-1/4") .....
Machine size (LxWxH).....	103 x 63 x 105cm (40.5"x25"x41.2") .....	103 x 63 x 105cm (40.5"x25"x41.2") .....
Base footprint (LxW).....	17" x 21" (43x53cm) .....	17" x 21" (43x53cm) .....

### Dust Extraction:

Dust port outside diameter .....	3" (76.2mm) .....	3" (76.2mm) .....
Dust collection minimum capacity required.....	450 cfm (12.74cmm) .....	450 cfm (12.74cmm) .....

### Weights:

Net.....	90 kg (198.4 lb) .....	90 kg (198.4 lb) .....
Shipping.....	130 kg (286.6 lb) .....	130 kg (286.6 lb) .....

<sup>1</sup> subject to local and national electrical codes.

<sup>2</sup> no load with dust collection.      <sup>3</sup> grinding flat bar 50x15mm with dust collection.

*The specifications in this manual were current at time of publication, but because of our policy of continuous improvement, Walter Meier reserves the right to change specifications at any time and without prior notice, without incurring obligations.*

## 7.0 Set-Up and Assembly

### 7.1 Floor Diagram

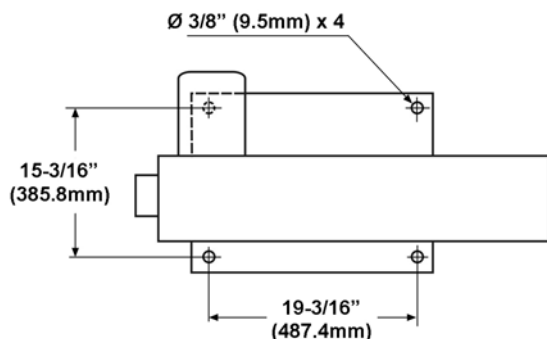

Figure 2

### 7.2 Unpacking and cleanup

Inspect contents of shipping container for shipping damage. Report any damage to your distributor.

Remove all contents from carton, and compare to the contents list in this manual. Report any part shortages to your distributor.

Do not discard carton or packing material until belt grinder is assembled and running satisfactorily.

Exposed metal areas may have a rust protectant applied. Remove this with a soft rag and WD-40® or kerosene. (Do not use gasoline, paint thinner, acetone, etc., as these will damage painted surfaces.)

#### Contents of shipping container

- 1 Belt Grinder
- 1 Instructions and Parts Manual (not shown)
- 1 Warranty Card (not shown)

### 7.3 Electrical Connections

**⚠WARNING** Electrical connections must be made by a qualified electrician in compliance with all relevant codes. This machine must be properly grounded to help prevent electrical shock and possible fatal injury.

The belt grinder is equipped with a single phase 230 volt only motor; or a 3-phase 230/460V (prewired 230V) motor. A plug is not included.

You may either install a UL/CSA listed plug suitable for the specified voltage, or hard-wire the machine directly to a service panel.

If the machine is to be hard-wired to a panel, make sure a disconnect is available for the

operator. During hard-wiring of the machine, make sure the fuses have been removed or the breakers have been tripped in the circuit to which the machine will be connected. Place a warning placard on the fuse holder or circuit breaker to prevent it being turned on while the machine is being wired.

#### Grounding Instructions

This machine must be grounded. In the event of a malfunction or breakdown, grounding provides a path of least resistance for electric current to reduce the risk of electric shock.

Improper connection of the equipment-grounding conductor can result in a risk of electric shock. The conductor with insulation having an outer surface that is green with or without yellow stripes, is the equipment-grounding conductor. If repair or replacement of the electric cord or plug is necessary, do not connect the equipment-grounding conductor to a live terminal.

Check with a qualified electrician or service personnel if the grounding instructions are not completely understood, or if in doubt as to whether the tool is properly grounded. Repair or replace a damaged or worn cord immediately.

Make sure the voltage of your power supply matches the specifications on the motor plate of the belt grinder.

It is recommended that the **single-phase** belt grinder be connected to a dedicated, minimum 50 amp circuit with a 50 amp circuit breaker or time-delay fuse; the **three phase** belt grinder (at **230 volt** operation) be connected to a dedicated minimum 30 amp circuit with a 30 amp circuit breaker or time delay fuse; and the **three phase** belt grinder (at **460 volt** operation) be connected to a dedicated, minimum 15 amp circuit with 15 amp circuit breaker or time delay fuse. **Local codes take precedence over recommendations.**

### 7.4 Voltage Conversion (3PH only)

To convert the 3-phase belt grinder from 230 to 460 volt operation:

1. Switch the incoming power leads according to the diagram inside the motor junction box. Similar diagrams are found in Section 13 of this manual. (In case of discrepancy, the diagrams in the motor junction box will take precedence.)
2. Make sure connections to transformer are suitable for the new voltage.
3. If a plug is being used, install a UL/CSA listed plug suitable for 460 volt operation.



## Extension Cords

The use of extension cords is discouraged; try to position machines within reach of the power source. If an extension cord becomes necessary, make sure the cord rating is suitable for the amperage listed on the machine's motor plate. An undersized cord will cause a drop in line voltage resulting in loss of power and overheating.

Use Table 1 as a general guide in choosing the correct size cord. If in doubt, use the next heavier gauge. The smaller the gauge number, the heavier the cord.

Recommended Gauges (AWG) of Extension Cords

Amps	Extension Cord Length *					
	25 feet	50 feet	75 feet	100 feet	150 feet	200 feet
< 5	16	16	16	14	12	12
5 to 8	16	16	14	12	10	NR
8 to 12	14	14	12	10	NR	NR
12 to 15	12	12	10	10	NR	NR
15 to 20	10	10	10	NR	NR	NR
21 to 30	10	NR	NR	NR	NR	NR

\*based on limiting the line voltage drop to 5V at 150% of the rated amperes.

NR: Not Recommended.

Table 1

## 8.0 Adjustments

Numbers in parentheses refer to Figure 1.

### 8.1 Belt tracking

1. Open side panel (13) and spin drive wheel (11) by hand to check preliminary tracking.
2. Use tracking knob (7) to correct until belt runs centered on wheels. Clockwise knob rotation shifts belt toward the left; counterclockwise toward the right, as viewed from the contact wheel end.
3. Close side panel (13).
4. Connect machine to power and turn on to check final tracking. Adjust as needed with knob.

**⚠ WARNING** Do not operate machine with side panel open.

### 8.2 Belt change

1. Disconnect machine from power.

2. Allow belt to completely stop, then remove spark trap (1).
3. Open side cover, and slacken belt by pushing tension release lever (8) downward (counterclockwise).
4. Install new belt according to direction arrows printed on belt.
5. Move tension release lever (8) upward (clockwise) to tighten belt.
6. Close side cover and reinstall spark trap (1).

### 8.3 Belt tension adjustment

Belt tension has been adjusted by the manufacturer. If future adjustment is needed, distance between the wheels can be changed using the two hex nuts (17).

## 9.0 Operation

### 9.1 Contact grinding

The operator faces the contact wheel (4) and holds the work piece with both hands. *Note: Keep hands away from contact area, which will grow warm during operation.*

The work piece is pushed against belt, and rested upon front work support (3) if needed.

### 9.2 Surface grinding

The operator faces the open belt guard (6) during surface grinding. The work piece is held with both hands and pushed hard against the top work support (5).

## 10.0 Maintenance

**⚠ WARNING** Before doing maintenance on the machine, disconnect it from the electrical supply by pulling out the plug or switching off the main switch! Failure to comply may cause serious injury.

Ball bearings have been packed with grease and sealed, and require no further lubrication.

Frequent cleaning is mandatory to ensure best operation and extended life of the belt grinder.

If graphite layer becomes damaged, replace it.

Use a brush to remove swarf from the wheels and interior.

Check belt periodically for cuts, frays, or worn areas. Replace belt when these symptoms are found.

Empty spark trap frequently.

If power cord is worn, cut, or damaged in any way, have it replaced immediately.

## 11.0 Troubleshooting

Trouble	Probable Cause	Remedy
Grinder will not start.	No incoming power.	Check all connections.
	Fuse blown, or circuit breaker tripped.	Replace fuse, or reset circuit breaker.
	Cord damaged.	Replace cord.
	Starting capacitor malfunction (single phase model).	Replace starting capacitor.
Poor belt tracking.	Improper belt splice.	Check belt for irregular seam or shape.
	Excessive or insufficient belt tension.	Set tension so belt is just taut.
	Worn contact surfaces.	Check durometer on contact wheel. Replace worn wheel.
	Misaligned wheels.	Check alignment of drive and contact wheel. Adjust using tracking knob.
	Lack of crown on drive wheel.	Check for slight crown (approx. 1/16"). Replace drive wheel if crown is not present.
Slack belt.	Insufficient belt tension.	Set tension so belt is just taut.
Premature wear of contact wheel.	Excessive belt tension.	Set tension so belt is just taut.
	Grinding on one area of belt.	Use entire belt work surface whenever possible.
	Excess deposits on belt; debris in machine.	Clean or replace belt. Periodically clean interior of grinder.
Short belt life.	Excessive grinding pressure.	Allow belt to do the cutting. Excessive pressure dulls belt and removes its grit.
	Grinding on one area of belt.	Use entire belt work surface whenever possible.

Table 2

## 12.0 Replacement Parts

Replacement parts are listed on the following pages. To order parts or reach our service department, call 1-800-274-6848, Monday through Friday (see our website for business hours, [www.waltermeier.com](http://www.waltermeier.com)). Having the Model Number and Serial Number of your machine available when you call will allow us to serve you quickly and accurately.

12.1.1 BG-379 Belt Grinders – Exploded View

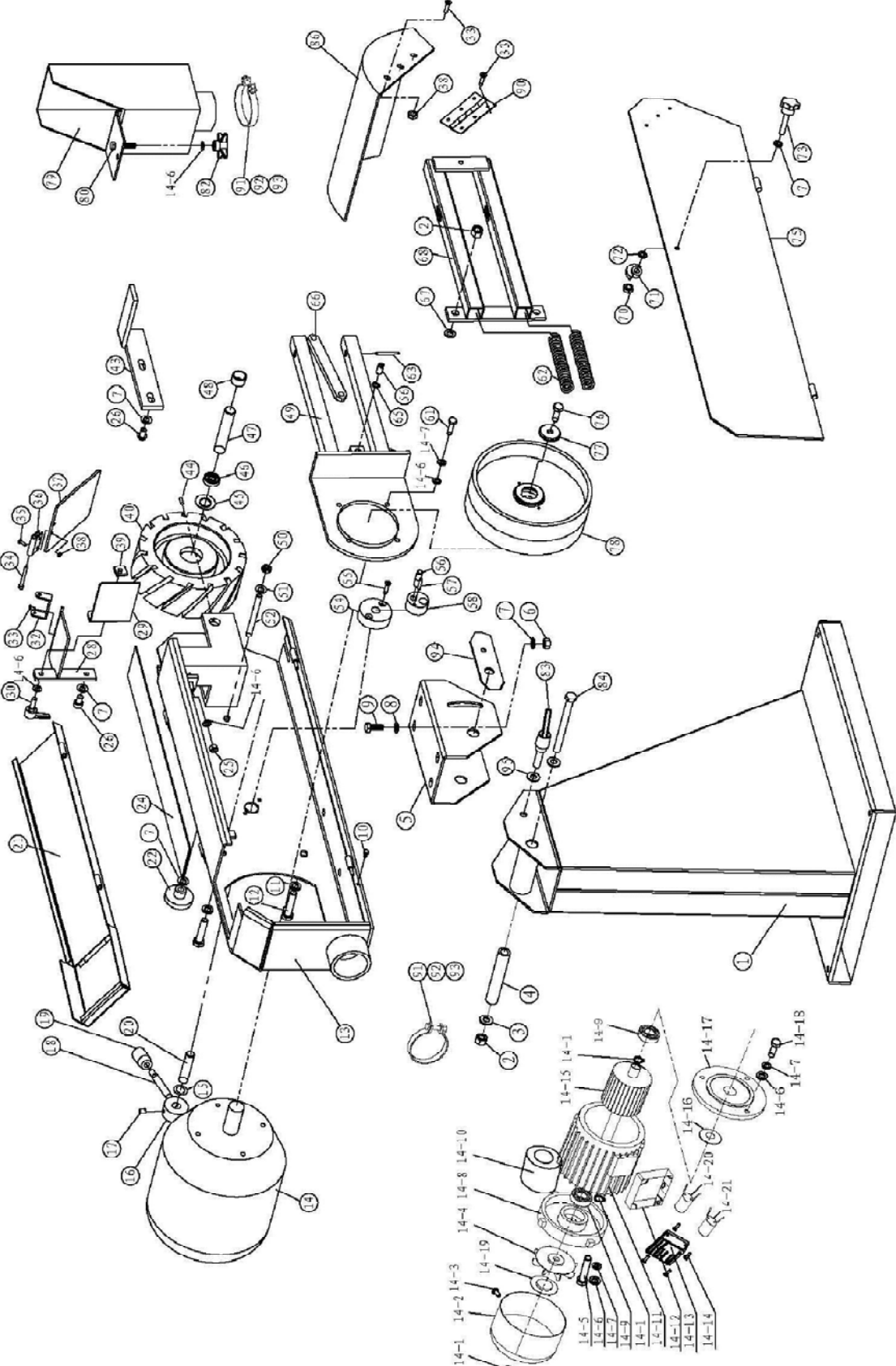

## 12.1.2 BG-379 Belt Grinders – Exploded View

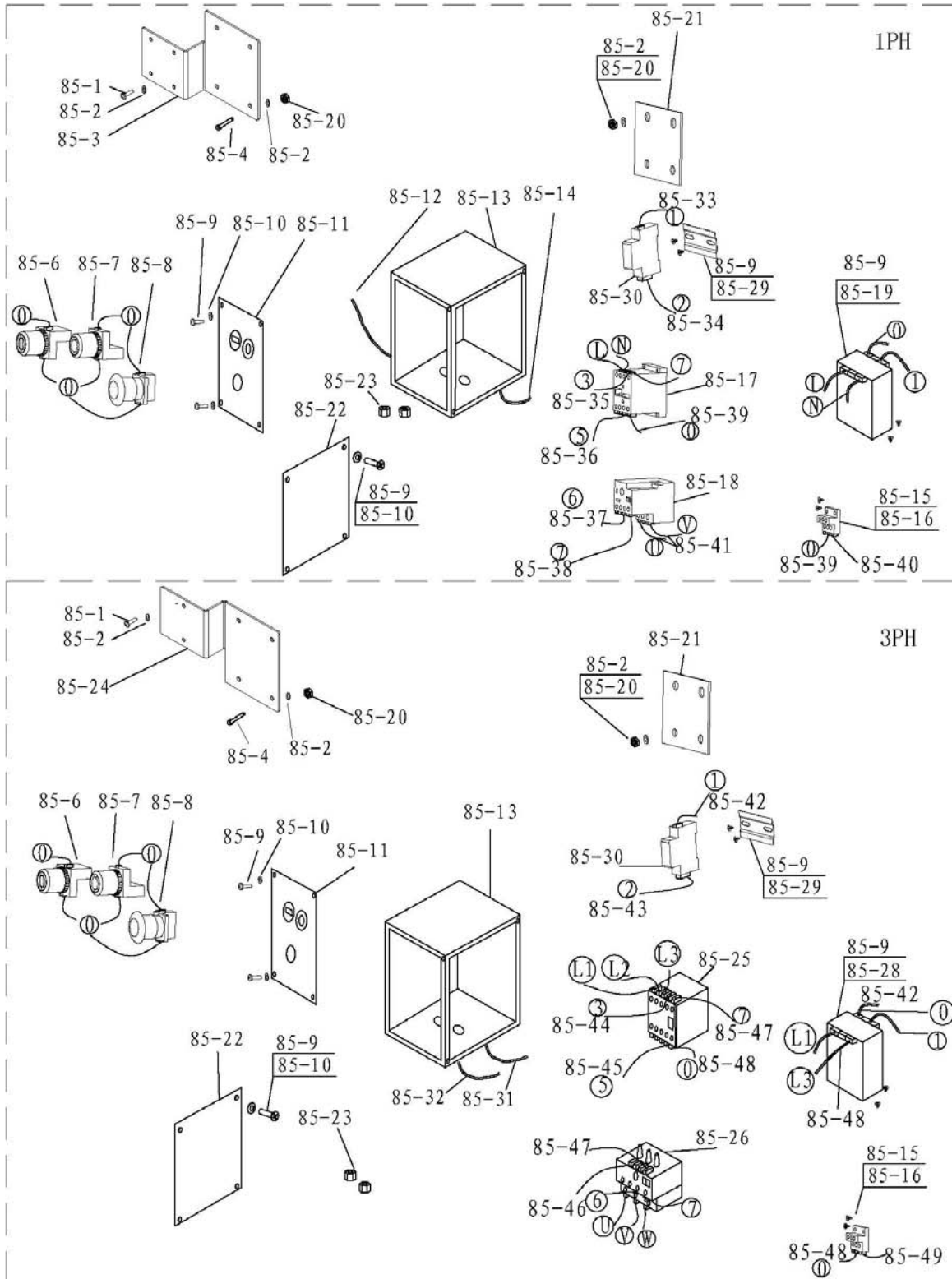

### 12.1.3 BG-379 Belt Grinders – Parts List

Index No.	Part No.	Description	Size	Qty
1	S-75B-000	Stand		1
2	TS-2342121	Nylon Lock Hex Nut	M12	3
3	TS-2360121	Flat Washer	12mm	2
4	S-75B-006	Inside Tube		1
5	S-75B-004	Stand		1
6	TS-1540071	Hex Nut	M10	4
7	TS-1550071	Flat Washer	10mm	9
8	BG379-08	Internal Serrated Washer	10mm	4
9	BG379-09	Socket Head Flat Screw	M10x20	4
10	TS-1502021	Socket Head Cap Screw	M5x10	2
11	BG379-11	External Serrated Washer	12mm	2
12	TS-1517041	Socket Head Flat Screw	M12x50	2
13	S-75-1003	Body		1
14	S-75-14/1	Motor (for 1PH)	4HP 1PH 230V	1
	S-75-14/3	Motor (for 3PH)	4HP 3PH 230/460V	1
14-1	BG379-14-1	Retaining Ring	25mm	3
14-2	S-75-14-2	Motor Fan Cover (for 1PH)		1
	S-75-14-2/3	Motor Fan Cover (for 3PH)		1
14-3	TS-1501031	Socket Head Cap Screw	M4x10	3
14-4	S-75-14-4	Motor Fan (for 1PH)		1
	S-75-14-4/3	Motor Fan (for 3PH)		1
14-5	TS-1490041	Hex Cap Screw	M8x25	3
14-6	TS-1550061	Flat Washer	8mm	11
14-7	TS-2361081	Lock Washer	8mm	7
14-8	S-75-14-8	Housing Cover		1
14-9	BB-6206	Ball Bearing	6206	2
14-10	S-75-14-10/1	Stator (for 1PH)		1
	S-75-14-10/3	Stator (for 3PH)		1
14-11	S-75-14-11	Motor Canister		1
14-12	S-75-14-12	Upper Junction Box		1
14-13	S-75-14-13	Lower Junction Box		1
14-14	TS-2284082	Phillips Pan Head Machine Screw	M4x8	4
14-15	S-75-14-15/1	Rotor (for 1PH)		1
	S-75-14-15/3	Rotor (for 3PH)		1
14-16	S-75-14-16	Washer		1
14-17	S-75-14-17	Cover		1
14-18	BG379-14-18	Hex Bolt (fully threaded)	M8x20	3
14-19	S-75-14-19	Centrifugal Switch (for 1PH)		1
14-20	S-75-14-20	Start Capacitor (for 1PH)	400 $\mu$ F, 250VAC	1
14-21	S-75-14-21	Run Capacitor (for 1PH)	50 $\mu$ F, 450VAC	1
15	S-75-1022	Thin Plain Washer		1
16	S-75-1023	Belt Tension Release Base		1
17	TS-1504031	Socket Head Cap Screw	M8x16	1
18	S-75-1024	Belt Tension Release Lever		1
19	BG379-19	Sleeve	M10x50	1
20	S-75-1019	Shaft		1
21	S-75-1001	Belt Guard		1
22	S-75-22	Locking Handle	10x63mm	1
24	S-75-24	Graphite Layer	520x75mm	1
25	TS-1540061	Hex Nut	M8	2
26	BG379-26	Socket Head Flat Screw	M10x16	3
28	S-75-1030	Top Work Support		1
29	S-75-1033	Top Work Support Plate		1
30	BG379-30	Lock Handle	M8x63	1
32	S-75-1032	Eye Protection Base		1
33	TS-1532042	Phillips Pan Head Machine Screw	M4x12	8
34	BG379-34	Socket Head Cap Screw	M5x50	1
35	5712561	Phillips Pan Head Machine Screw	M5x8	2
36	S-75-1031	Eye Protection Hinge		1

Index No.	Part No.	Description	Size	Qty
37	S-75-1029	Eye Protection Cover		1
38	TS-1540021	Hex Nut	M4	5
39	S-75-1034	Block with Thread		1
40	S-75-1011	Contact Wheel		1
43	S-75-1013	Work Support		1
44	TS-1513031	Socket Head Flat Screw	M5x16	1
45	BG379-45	Stop Ring	42mm	2
46	BB-6004ZZ	Ball Bearing	6004ZZ	2
47	S-75-1012	Shaft		1
48	S-75-1014	Spacer		2
49	S-75-1002	Motor Support		1
50	TS-1541041	Nylon Lock Hex Nut	M10	1
51	BG379-51	Butterfly Spring	10mm	1
52	S-75-1025	Screw Bar		1
54	S-75-1021	Base		1
55	BG379-55	Socket Head Countersunk Screw	M6x25	2
56	S-75-1017	Shaft		1
57	SBR30M-62	Spring Pin	5x20mm	1
58	S-75-1020	Eccentric wheel		1
61	BG379-61	Hex Bolt, fully threaded	M8x22	4
62	S-75-1015	Spring		2
63	BG379-63	Elasticity pin	6x40mm	2
65	BG379-65	Retaining Ring	10mm	3
66	S-75-1018	Draw Bar		1
67	BG379-67	Butterfly Spring	12mm	12
68	S-75-1016	Support		1
70	TS-2245081	Socket Head Flat Screw	M5x8	1
71	PRS76-044	Catch		1
72	BG379-72	Thin Hex Nut	M10	1
73	S-75-73	Wing Handle	M10x25	1
75	S-75-1035	Side Panel		1
76	BG379-76	Hex Bolt, fully threaded	M10x30	1
77	S-75-1009	Washer		1
78	S-75-1008	Drive Wheel		1
79	S-75-1036	Spark Trap		1
80	BG379-80	Hex Bolt, fully threaded	M8x15	1
82	S-75-1037	Knob		1
83	S-75-83	Adjustable Handle	M12x32	1
84	BG379-84	Hex Screw	M12x140	1
85-1	618M1-0216	Phillips Pan Head Machine Screw (for 1PH)	M5x8	4
	618M1-0216	Phillips Pan Head Machine Screw (for 3PH)	M5x8	2
85-2	TS-1550031	Flat Washer (for 1PH)	5mm	8
	TS-1550031	Flat Washer (for 3PH)	5mm	6
85-3	S-75-85-3	Bracket (for 1PH)		1
85-4	TS-1533052	Phillips Pan Head Machine Screw (for 1PH)	M5x16	4
85-6	S-75-85-6	Start Switch (for 1PH)		1
	S-75-85-6/3	Start Switch (for 3PH)		1
85-7	S-75-85-7	Stop Switch (for 1PH)		1
	S-75-85-7/3	Stop Switch (for 3PH)		1
85-8	S-75-85-8	Emergency Switch (for 1PH)	SB	1
	S-75-85-8/3	Emergency Switch (for 3PH)	SB	1
85-9	TS-2284082	Pan Head Machine Screw	M4x8	14
85-10	TS-1550021	Flat Washer	4mm	8
85-11	S-75-85-11	Electric Box Cover (for 1PH)		1
	S-75-85-11/3	Electric Box Cover (for 3PH)		1
85-12	S-75-85-12/1	Cable (for 1PH)		1
85-13	S-75-85-13	Electric Box (for 1PH)		1
	S-75-85-13/3	Electric Box (for 3PH)		1
85-14	S-75-85-14	Cable	3x2.5	1
85-15	TS-1532042	Phillips Pan Head Machine Screw	M4x12	2

Index No.	Part No.	Description	Size	Qty
85-16	S-75-85-16	Grounding Copper (for 1PH)		1
	S-75-85-16/3	Grounding Copper (for 3PH)		1
85-17	S-75-85-17	A.C. Contactor (for 1PH)	KM	1
85-18	S-75-85-18	Thermal Relay (for 1PH)	FR	1
85-19	S-75-85-19	Transformer (for 1PH)		1
85-20	TS-1540031	Hex Nut (for 1PH)	M5	4
	TS-1540031	Hex Nut (for 3PH)	M5	8
85-21	S75-85-21	Board (for 1PH)		1
	S75-85-21/3	Board (for 3PH)		1
85-22	S75-85-22	Cover Plate (for 1PH)		1
	S75-85-22/3	Cover Plate (for 3PH)		1
85-23	S75-85-23	Strain Relief	M20x1.5	2
85-24	S75-85-24	Bracket (for 3PH)		1
85-25	S75-85-25	A.C. Contactor (for 3PH)	KM	1
85-26	S75-85-26	Thermal Relay (for 3PH)	FR	1
85-28	S75-85-28	Transformer (for 3PH)	1.5/0.75	1
85-29	S75-85-29	Holder (for 1PH)		1
	S75-85-29/3	Holder (for 3PH)		1
85-30	S75-85-30	Breaker (for 1PH)		1
	S75-85-30/3	Breaker (for 3PH)		1
85-31	S-75-85-31	Cable (for 3PH)	3.3m, 16 AWG x 4C	1
85-32	S-75-85-32	Cable (for 3PH)	0.8m, 16 AWG x 4C	1
85-33	S-75-85-33	Cable (for 1PH)	0.341M, 18 AWG	1
85-34	S-75-85-34	Cable (for 1PH)	0.196m, 18 AWG	1
85-35	S-75-85-35	Cable (for 1PH)	0.433m, 18 AWG	1
85-36	S-75-85-36	Cable (for 1PH)	0.479m, 18 AWG	1
85-37	S-75-85-37	Cable (for 1PH)	0.435m, 18 AWG	1
85-38	S-75-85-38	Cable (for 1PH)	0.3m, 18 AWG	1
85-39	S-75-85-39	Cable (for 1PH)	0.215m, 18 AWG	1
85-40	S-75-85-40	PE Cable (for 1PH)	0.115m, 16 AWG	1
85-41	S-75-85-41	UV Cable (for 1PH)	12 AWG	1
85-42	S-75-85-42	Cable (for 3PH)	0.332m, 18 AWG	1
85-43	S-75-85-43	Cable (for 3PH)	0.181m, 18 AWG	1
85-44	S-75-85-44	Cable (for 3PH)	0.415m, 18 AWG	1
85-45	S-75-85-45	Cable (for 3PH)	0.468m, 18 AWG	1
85-46	S-75-85-46	Cable (for 3PH)	0.412m, 18 AWG	1
85-47	S-75-85-47	Cable (for 3PH)	0.300m, 18 AWG	1
85-48	S-75-85-48	Cable (for 3PH)	0.200m, 18 AWG	1
85-49	S-75-85-49	PE Cable (for 3PH)	0.115m, 16 AWG	1
LN	S-75-85-LN	LN Cable to TC (for 1PH)	16 AWG	1
LN	S-75-85-LN	LN Cable to KM1 (for 1PH)	16 AWGx3C	1
L1/L3	S-75-85-L1L3	L1/L3 Cable to TC (for 3PH)	16 AWG	1
U/V/W	S-75-85-UVW	U/V/W Cable to FR (for 3PH)	16 AWGx4C	1
L1/L2/L3	S-75-85-L1L2L3	L1/L2/L3 Cable to KM1 (for 3PH)	16 AWGx4C	1
86	S-75-040	Safety Guard		1
90	S-75-90	Hinge		1
91	S-75-91	Hose Clamp		4
92	TS-2285352	Phillips Pan Head Machine Screw	M5x35	4
93	TS-1540031	Hex Nut	M5	2
94	S-75-94	Pad		2
95	S-75-95	Large Washer	Ø30x Ø12.5x3mm	1
	BG379-94	Label – Read Manual (not shown)	Ø1.5"	1
	BG379-95	Label – Alert Symbol (not shown)	Ø1.5"	1
	BG379-96	Label – Eye Protection (not shown)	Ø1.5"	1
	BG379-97	Label – Hearing Protection (not shown)	Ø1.5"	1
	BG379-WL	Warning Label (not shown)	2" x 4-1/4"	1
	JETLOGO-1	Jet Logo Plate (not shown)	2-3/4" x 8"	1
	STRIPE-1-3/4	JET Stripe (not shown)	1-3/4" w	per ft.

# 13.0 Electrical Connections – single phase only

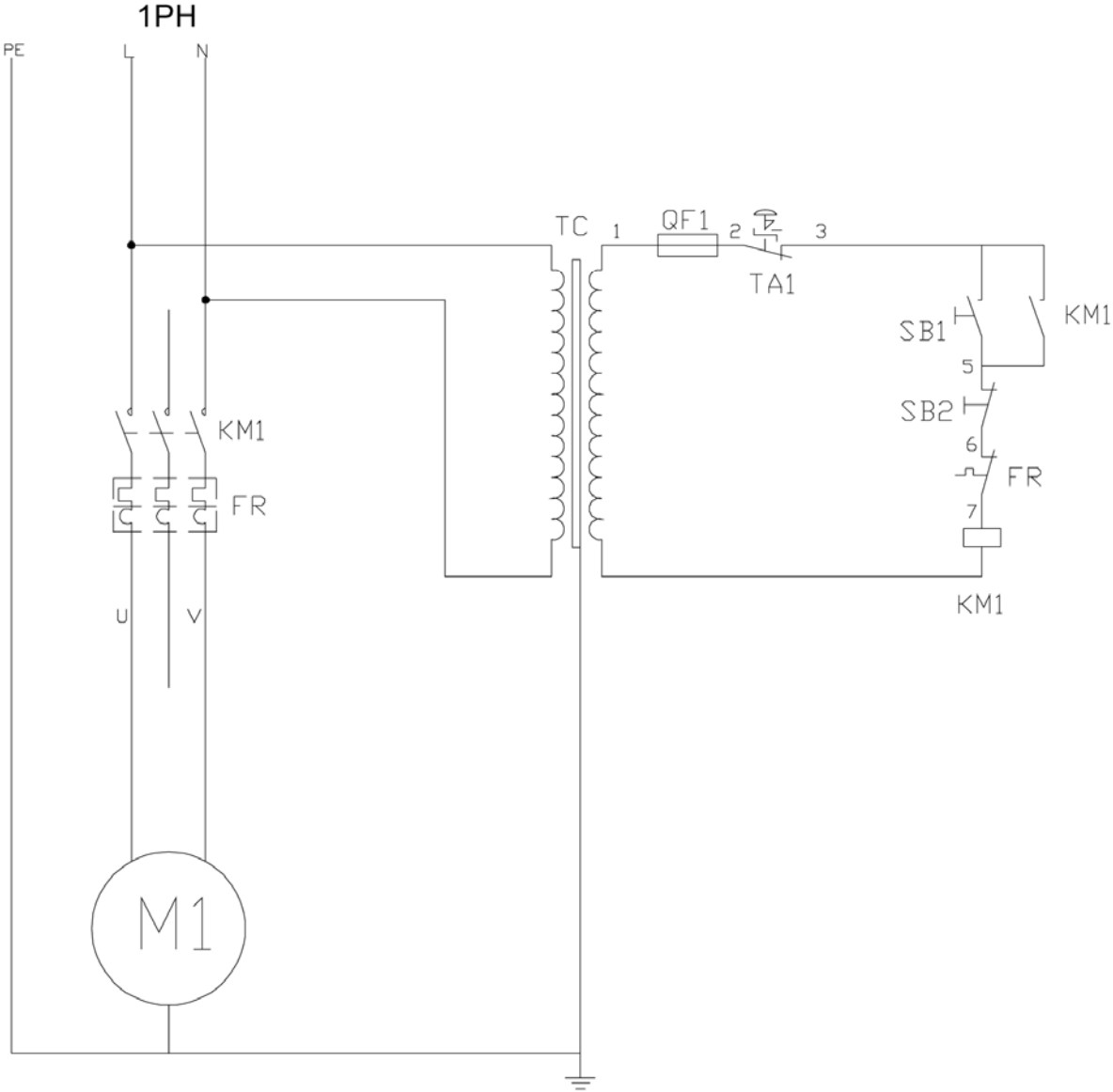



# 13.2 Electrical Connections – 3 phase only

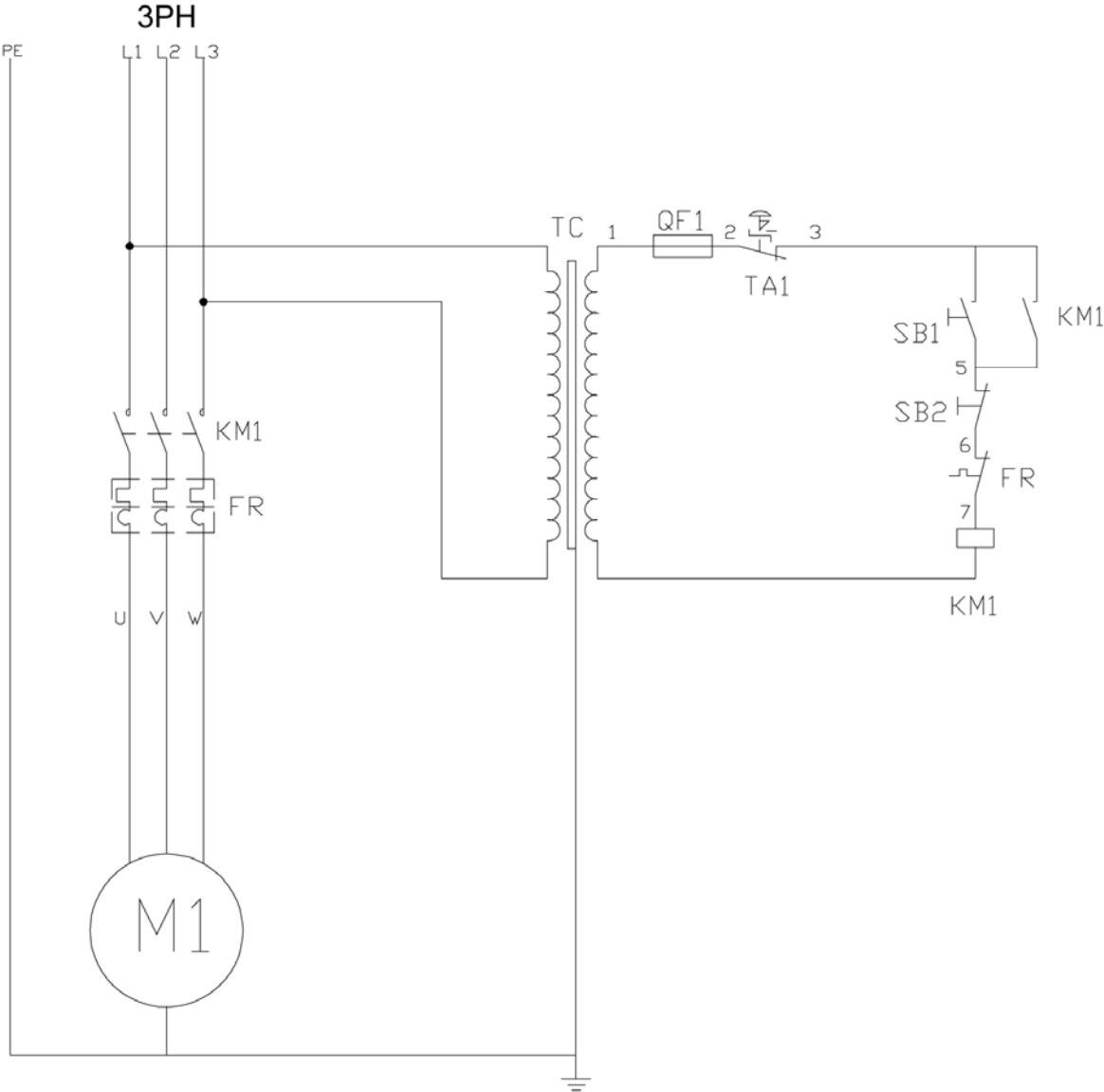

This page intentionally left blank

This page intentionally left blank



**WALTER MEIER (Manufacturing) Inc.**

427 New Sanford Road  
LaVergne, Tennessee 37086  
Phone: 800-274-6848  
[www.waltermeier.com](http://www.waltermeier.com)