



SERVICE PARTS LIST

BUL. 54-22-2037

4" GRINDER

REVISED BUL 54-22-2036 DATE Jan. '70

Catalog No. 5200

Starting Serial No. **74-3511**

WIRING INSTR. **58-01-0310**

Both Model and Serial No. must be furnished to obtain correct parts.

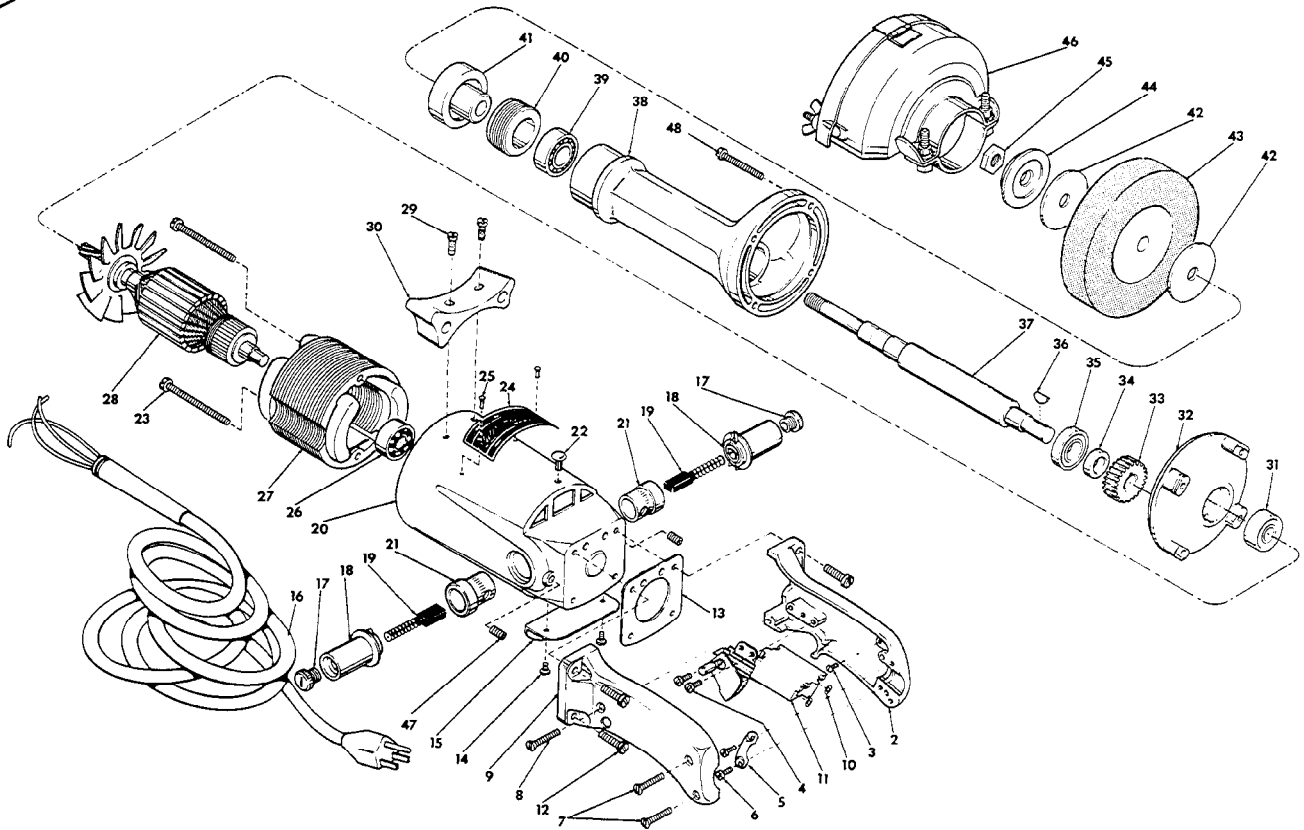

FIG.	PART NO.	DESCRIPTION OF PART	NO.REQ.	FIG.	PART NO.	DESCRIPTION OF PART	NO.REQ.
1	14-78-0100	Switch Handle Assembly (Includes Fig. Nos. 2 thru 9)		24	12-98-3500	Name Plate	
2	28-44-1041	Handle (Switch Mount Side)		★25	06-77-0625	6x1/4 Rd. Driv-In Screw	(2)
3	06-81-8625	6-32x1/4 Rd.Hd. Bronze		26	02-04-1070	Ball Bearing	
4	06-81-5400	8-32x5/16 Binder Sem	(2)	27	18-82-1110	Field Assembly	
5	28-17-0200	Clamp Strap		28	16-82-1660	Armature Assembly	
6	06-81-6150	8-32x1/2 Fil.Hd. Sem	(2)	29	06-81-6950	10-24x1/2 Fil.Hd. Sem	(2)
7	06-81-3700	8-32x7/8 Oval Hd. Screw	(2)	30	28-79-0241	Tool Rest	
8	06-81-3750	8-32x1 Oval Hd. Screw		31	02-04-1260	Ball Bearing	
9	28-44-9081	Handle (Switch Cover Side)		32	28-28-0421	Diaphragm	
10	06-97-1800	Lockwasher	(4)	33	32-75-2201	Spindle Gear	
11	23-66-0250	Switch		34	45-36-0220	Spindle Gear Spacer	
★12	06-81-7620	12-28x3/4 Fil.Hd. Sem	(4)	35	02-04-1520	Ball Bearing	
13	43-86-0050	Handle Insulator		36	06-42-2000	Woodruff Key	
14	06-81-8650	6-32x1/4 Rd.Hd. Sem	(2)	37	38-50-2051	Spindle	
15	44-66-0100	Cover Plate		38	28-50-7601	Spindle Housing	
16	22-64-0090	Cord Set		39	02-20-1720	Ball Bearing	
17	23-44-0065	Brush Retaining Screw	(2)	40	44-40-0180	Lock Nut	
18	22-22-0130	Brush Holder Assy.	(2)	41	43-34-0070	Inner Wheel Flange	
19	22-18-0260	Carbon Brush Assy.	(2)	42	45-88-0190	Rubber Washer	(2)
★20	28-50-4563	Motor Housing Assembly (Includes Fig. Nos. 21 thru 23)		43	49-92-1140	Grinding Wheel	
21	22-24-0100	Bushing	(2)	44	43-34-0050	Outer Wheel Flange	
22	06-77-1400	14x5/16 Driv-In Screw		45	06-55-2850	1/2-13 Hex Nut	
23	06-81-9200	10-24x2-1/2 Rd.Hd. Sem	(2)	46	43-54-0100	Wheel Guard Assy.	
				★47	06-83-2725	1/4-28x3/8 Hdls. Set Screw	(2)
				48	06-81-7150	10-24x1-3/8 Fil.Hd. Sem	(4)