



SERVICE PARTS LIST

BULLETIN NO.
54-24-5200

SPECIFY CATALOG NO. AND SERIAL NO. WHEN ORDERING PARTS		REVISED BULLETIN	DATE
5/8" (16mm) SDS Rotary Hammer			Oct. 2012
CATALOG NO. 5263-20	STARTING SERIAL NO. C59A	WIRING INSTRUCTION SEE PAGE 4	

EXAMPLE:
Component Parts (Small #) Are Included
When Ordering The Assembly (Large #).

FIG.	PART NO.	DESCRIPTION OF PART	NO. REQ.
1	05-73-0010	Screw	(1)
2	22-64-0575	Cord Set	(1)
3	12-20-0010	Service Nameplate	(1)
4	14-38-0010	Handle Housing Assembly	(1)
4a	-----	Right Handle Housing Halve	(1)
4b	-----	Left Handle Housing Halve	(1)
5	18-07-0065	Service Field	(1)
6	16-07-0045	Service Armature	(1)
7	22-84-0040	Fan	(1)
8	02-04-0305	Ball Bearing	(1)
9	44-90-0340	External Snap Ring	(1)

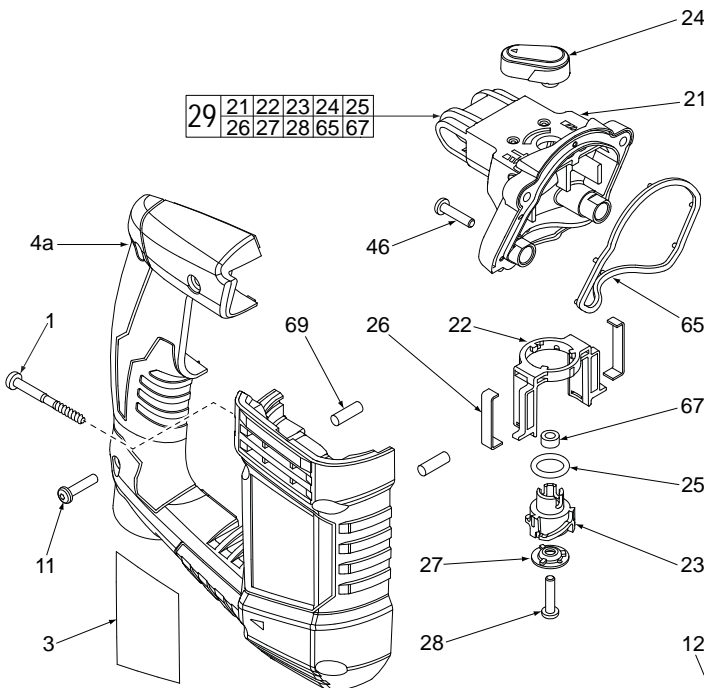
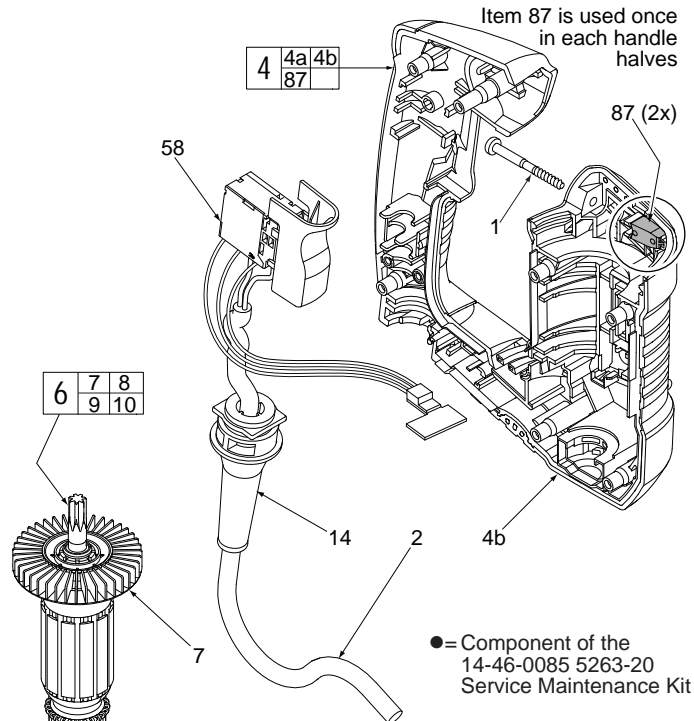

FIG.	PART NO.	DESCRIPTION OF PART	NO. REQ.
10	45-88-0925	Insulating Disc	(1)
11	05-81-0210	M4 x 18 Pan Hd. Plast. T-15 Screw	(7)
12	44-10-0055	Lever	(1)
13	22-22-0115	Brush Card	(1)
14	44-76-0035	Cord Protector	(1)
21	28-14-0095	Housing Cover	(1)
22	31-10-0010	Hammer Switch Carriage	(1)
23	31-88-0070	Pivot	(1)
24	44-10-0175	Lever	(1)
25	34-40-0235	O-Ring	(1)
26	44-86-0025	Fastening Bow	(2)
27	31-88-0080	Disc	(1)
28	05-81-0210	M4 x 18 Pan Hd. Plast. T-15 Screw	(1)
29	31-40-0125	Housing Cover Assembly	(1)
46	05-74-0105	Screw	(4)
58	23-66-0655	Switch Assembly	(1)
60	42-55-0235	Carrying Case	(1)
62	22-18-0030	● Carbon Brush (Set of 2)	(1)
63	45-22-0540	● Bearing Cup	(1)
65	43-44-0035	● Gasket	(1)
67	43-84-0010	● Felt	(1)
69	45-30-0045	● Rubber Slug	(2)
87	43-84-5200	Housing Insert	(2)
	23-94-0330	Leadwire Assembly (See wiring on page 4)	(1)
	23-94-0335	Leadwire Assembly (See wiring on page 4)	(1)



● = Component of the
14-46-0085 5263-20
Service Maintenance Kit



●14-46-0085

SERVICE MAINTENANCE KIT			
FIG.	PART NO.	DESCRIPTION	QTY.
62	22-18-0030	Carbon Brush Set	(1)
63	45-22-0540	Bearing Cup	(1)
65	43-44-0035	Gasket	(1)
67	43-84-0010	Felt	(1)
69	45-30-0045	Rubber Slug	(2)
64	42-52-5262	Dust Cap	(1)
66	44-90-0375	External Snap Ring	(1)
68	44-90-0085	Protection Washer	(1)
70	34-40-0285	O-Ring	(1)
71	44-90-0185	Retaining Ring	(1)
72	44-90-0195	Retaining Ring	(1)
73	44-90-0205	Protection Washer	(3)
74	34-40-1510	O-Ring	(1)
75	34-40-0305	O-Ring	(1)
76	42-76-0095	Thrust Collar	(2)
77	45-88-0985	Backing Flange	(1)
78	45-88-1060	Spacer	(1)
79	45-88-1115	Stop Washer	(1)
80	45-88-1145	Bearing Washer	(1)
81	45-88-1155	Disc Washer	(1)
82	42-36-0175	Backing Flange	(1)
83	05-74-0480	M5 x 25 Screw	(2)
84	34-40-0320	Seal Ring	(1)
85	34-40-0325	O-Ring	(1)
	49-08-5350	P' Grease (100g tube)	(1)
	49-08-5345	Q2' Grease (45g tube)	(1)

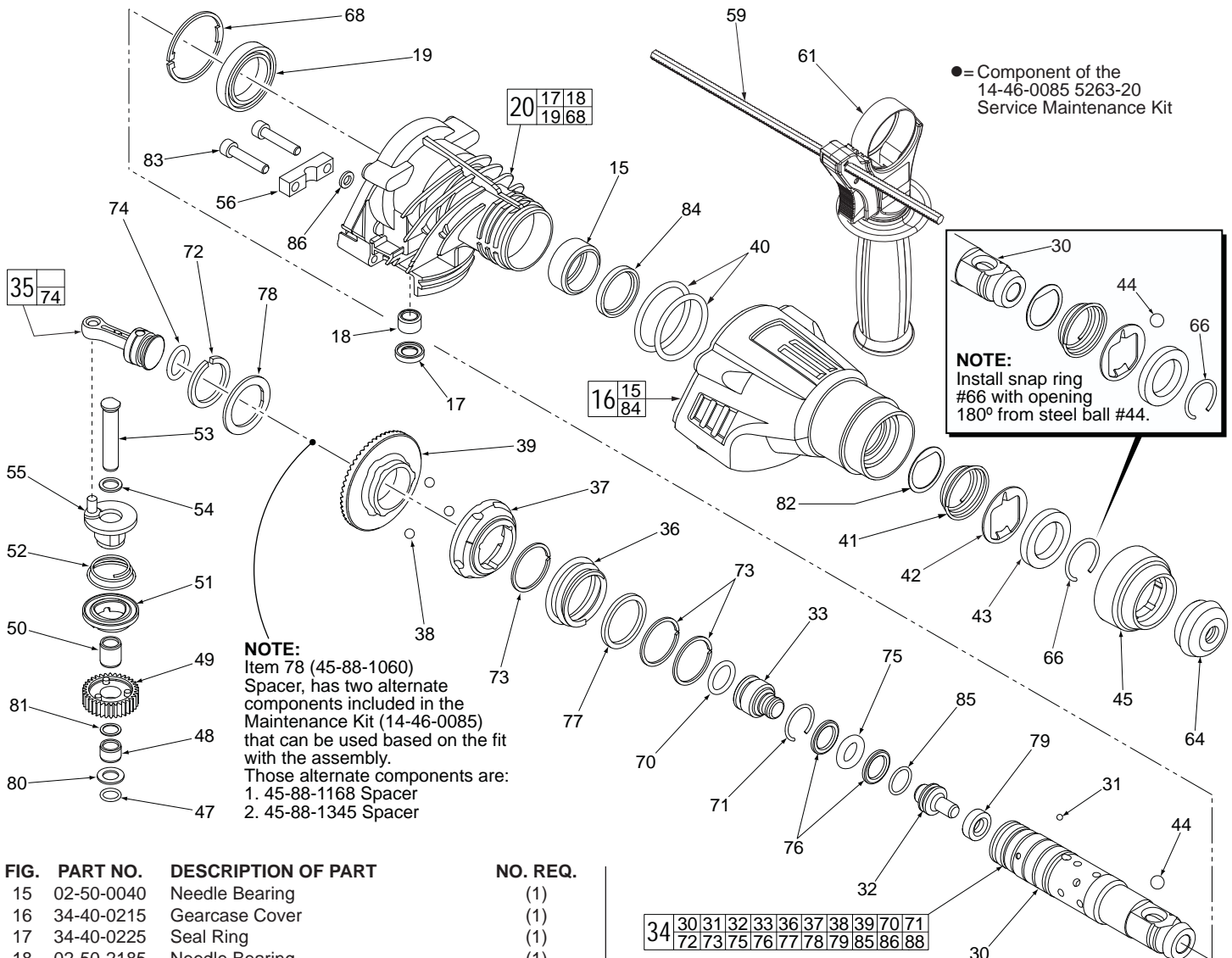

FIG.	PART NO.	DESCRIPTION OF PART	NO. REQ.
15	02-50-0040	Needle Bearing	(1)
16	34-40-0215	Gearcase Cover	(1)
17	34-40-0225	Seal Ring	(1)
18	02-50-2185	Needle Bearing	(1)
19	02-04-0310	Ball Bearing	(1)
20	28-14-0085	Gearcase	(1)
30	32-75-0075	Spindle Sleeve	(1)
31	02-04-0683	Steel Ball	(3)
32	45-08-0075	Striker	(1)
33	45-08-0080	Ram	(1)
34	32-75-0095	Spindle Sleeve Assembly	(1)
35	44-62-0020	Piston Assembly	(1)
36	40-50-0855	Spring	(1)
37	42-70-0020	Clutch Disc	(1)
38	02-02-1300	5mm Steel Ball	(3)
39	32-75-0125	Gear Wheel	(1)
40	34-40-0245	O-Ring	(2)
41	40-50-8045	Pressure Spring	(1)
42	42-36-1755	Support Plate	(1)
43	44-90-0075	Holding Ring	(1)
44	02-02-0185	Steel Ball	(1)
45	42-96-0030	Sleeve	(1)
47	34-40-0265	O-Ring	(1)
48	02-50-0045	Needle Bearing	(1)
49	32-75-0130	Gear	(1)
50	02-50-0055	Needle Bearing	(1)
51	42-70-0025	Clutch Ring	(1)
52	40-50-0865	Spring	(1)
53	44-60-0280	Pin	(1)
54	45-88-0965	Washer	(1)
55	43-16-0025	Eccentric Shaft	(1)
56	30-20-0020	Bearing Pin Clamp	(1)
59	43-46-0172	Depth Gauge	(1)
61	49-15-5300	Side Handle	(1)
64	42-52-5262	Dust Cap	(1)
66	44-90-0375	External Snap Ring	(1)
68	44-90-0085	Retaining Ring	(1)

34	30	31	32	33	36	37	38	39	70	71
	72	73	75	76	77	78	79	85	86	88

FIG.	PART NO.	DESCRIPTION OF PART	NO. REQ.
70	34-40-0285	● O-Ring	(1)
71	44-90-0185	● Retaining Ring	(1)
72	44-90-0195	● Retaining Ring	(1)
73	44-90-0205	● Retaining Ring	(3)
74	34-40-1510	● O-Ring	(1)
75	34-40-0305	● O-Ring	(1)
76	42-76-0095	● Thrust Collar	(2)
77	45-88-0985	● Flange Washer	(1)
78	45-88-1060	● Spacer	(1)
79	45-88-1115	● Stop Washer	(1)
80	45-88-1145	● Bearing Washer	(1)
81	45-88-1155	● Disc Washer	(1)
82	42-36-0175	● Backing Flange	(1)
83	05-74-0480	● M5 x 25 Screw	(2)
84	34-40-0320	● Seal Ring	(1)
85	34-40-0325	● O-Ring	(1)
86	45-88-0975	Washer	(1)
	14-46-0085	Maintenance Kit	(1)

LUBRICATION NOTES: Type 'Q2' Grease
No. 49-08-5345, 1.5 oz. / 45g tube

Type 'P' Grease
No. 49-08-5350, 3.5 oz. / 100g tube

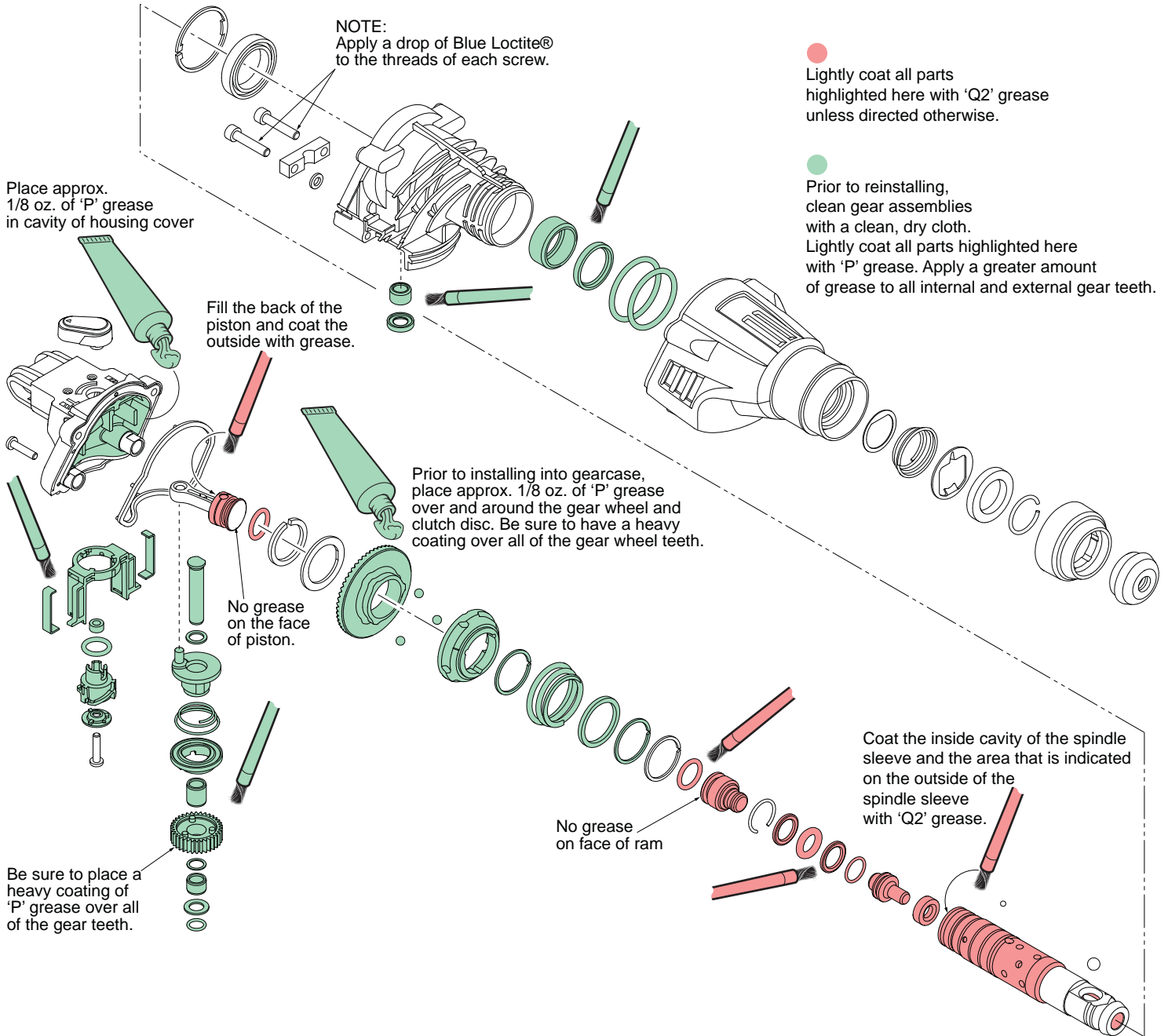

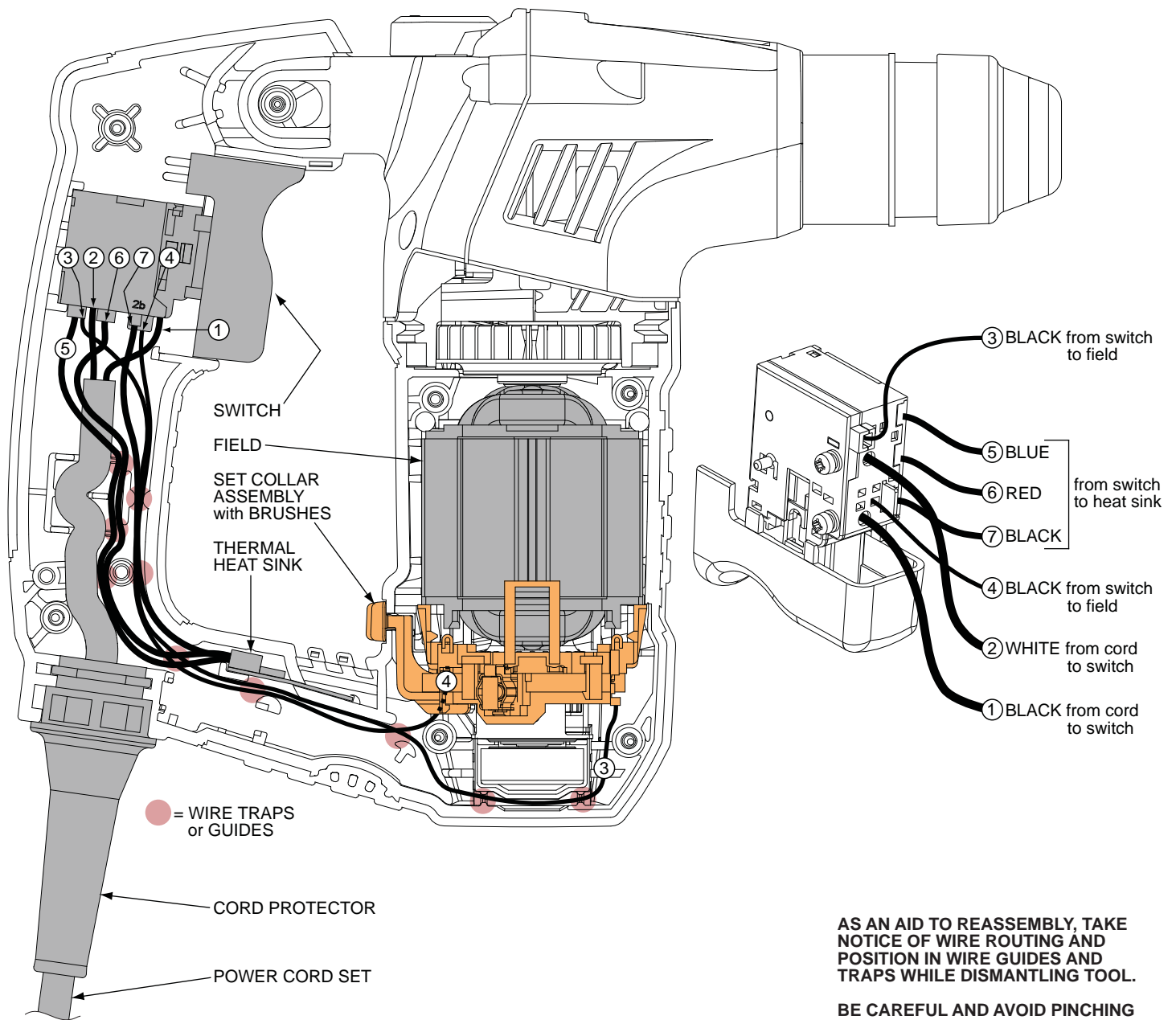

AS AN AID TO REASSEMBLY, TAKE NOTICE OF WIRE ROUTING AND POSITION IN WIRE GUIDES AND TRAPS WHILE DISMANTLING TOOL.

BE CAREFUL AND AVOID PINCHING WIRES BETWEEN HANDLE HALVES WHEN ASSEMBLING.

WIRING SPECIFICATIONS

Wire No.	Wire Color	Origin or Gauge	Length	Terminals, Connectors and 1 or 2 End Wire Preparation
1	Black	22-64-0575	-----	Component of cord set. Connect to switch as shown.
2	White	22-64-0575	-----	Component of cord set. Connect to switch as shown.
3	Black	23-94-0335	-----	Leadwire assembly. Connect to switch and front right position of the field as shown.
4	Black	23-94-0330	-----	Leadwire assembly. Connect to switch and rear left position of the field as shown.
5	Blue	23-66-0655	-----	Component of the switch assembly. Wired between the switch and the thermal heat sink.
6	Red	23-66-0655	-----	Component of the switch assembly. Wired between the switch and the thermal heat sink.
7	Black	23-66-0655	-----	Component of the switch assembly. Wired between the switch and the thermal heat sink.