

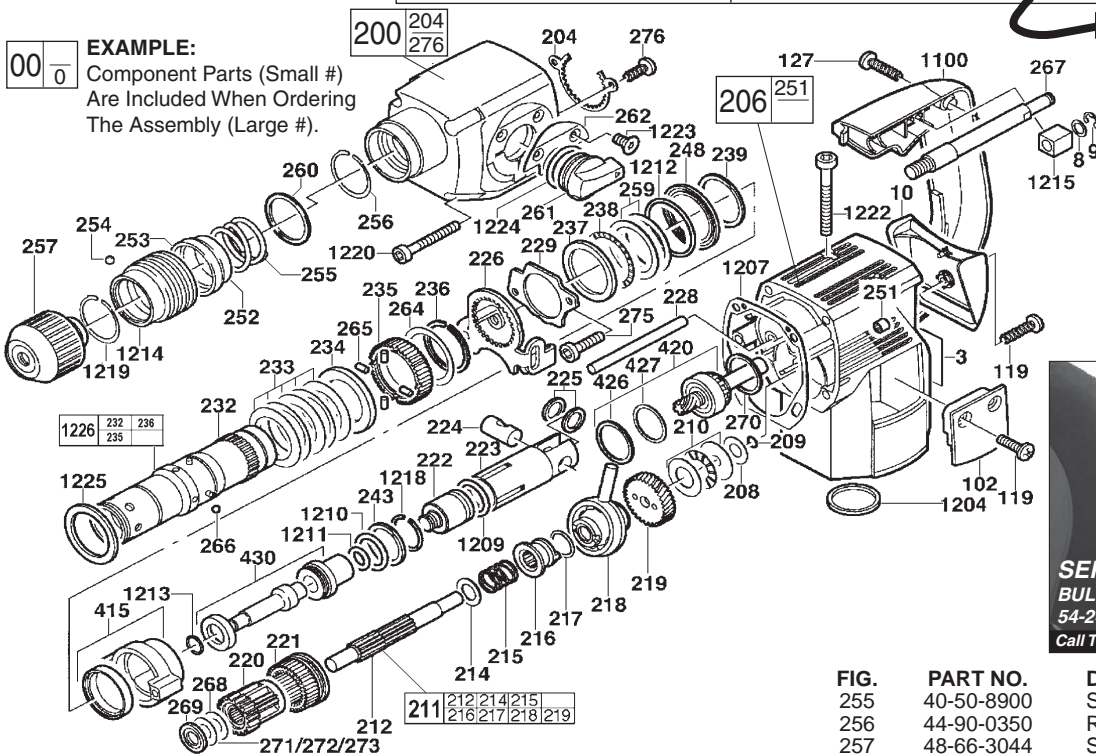

SERVICE PARTS LIST

SPECIFY CATALOG NO. AND SERIAL NO. WHEN ORDERING PARTS		REVISED BULLETIN	DATE
1-1/8" ROTARY HAMMER			Aug. 2007
CATALOG NO. 5360-21	SERIAL NUMBER 410A (See Service Note)	WIRING INSTRUCTION 58-01-1865	

EXAMPLE:
Component Parts (Small #)
Are Included When Ordering
The Assembly (Large #).



SERVICE NOTE: When servicing a 5360-21 Rotary Hammer with a serial number starting with 410A, first identify the series being serviced (Series I or Series II). Series I has a small taper on the strain relief. Use this bulletin, 54-24-5025, to order parts and service Series I tools. Series II has a large taper on the strain relief. Use bulletin 54-24-5026 (listed under serial number 410B) to order parts and service Series II tools.

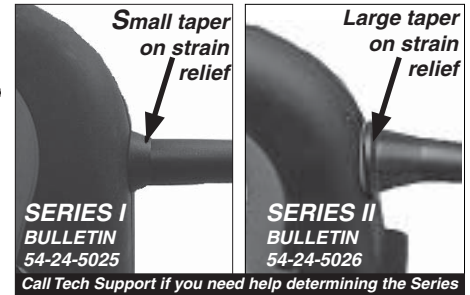
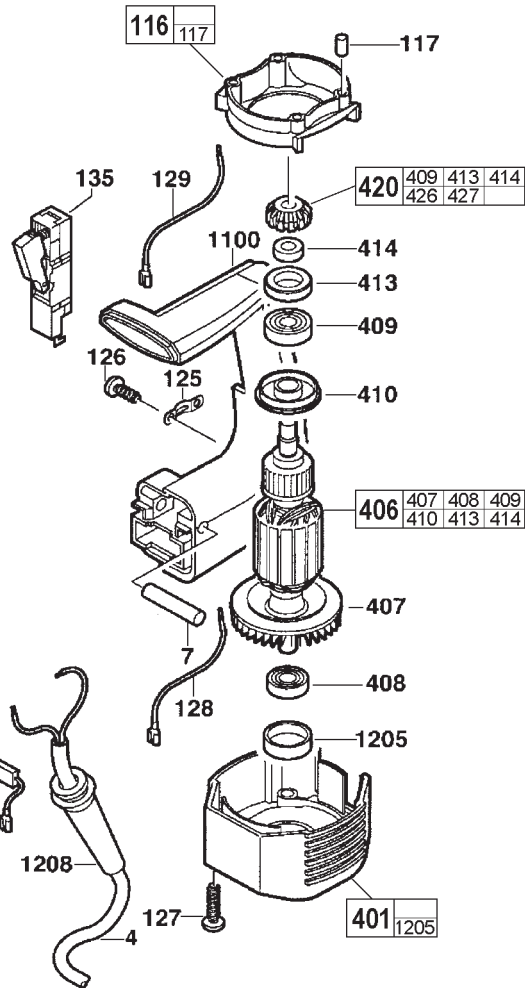

FIG.	PART NO.	DESCRIPTION OF PART	QTY.
3	12-20-5360	SERVICE NAMEPLATE KIT	1
8	45-88-1245	WASHER	1
9	44-90-0340	SNAP RING (EXT.)	1
10	31-15-0257	CRANKCASE COVER	1
102	31-15-0255	BRUSH COVER	2
119	05-78-0745	TAPTITE SCREW	5
127	05-78-0715	SCREW	7
200	31-40-0042	GEARCASE	1
204	44-86-0625	SPLINED RETAINER	1
206	31-15-0307	CRANKCASE	1
208	45-88-8825	WASHER (ADD AS REQUIRED)	1
209	34-40-4440	O-RING	1
210	02-80-6025	THRUST BEARING SET	1
211	14-73-0247	WOBBLE SHAFT ASSEMBLY	1
212	36-66-3162	REDUCTION GEAR SHAFT	1
214	45-88-1250	WASHER	1
215	40-50-8897	SPRING	1
216	45-22-0302	COUPLING SLEEVE	1
217	45-88-8414	WASHER	1
218	36-92-0747	WOBBLE PLATE	1
219	32-60-2622	REDUCTION GEAR	1
220	32-60-2157	OFFSET GEAR	1
★ 221	32-60-2165	INTERNAL GEAR	1
222	44-82-0192	RAM	1
223	44-62-0157	PISTON	1
224	44-60-1405	WRIST PIN	1
225	45-88-1180	WASHER	2
226	44-90-4500	SHIFT RING	1
228	44-60-1485	PIN	1
229	44-66-6055	RETAINING PLATE	1
232	-----	FIXTEC SPINDLE	1
233	40-50-7977	BELLEVILLE SPRING	5
234	45-88-7767	STOP WASHER	1
235	-----	SPINDLE GEAR	1
★ 236	-----	RETAINING RING (EXT.)	1
237	45-88-1255	WASHER	1
238	02-80-0150	THRUST WASHER	1
★ 239	45-88-0775	RETAINING RING	1
★ 243	42-76-0727	THRUST COLLAR	1
248	45-88-1265	WASHER	1
251	02-50-2185	NEEDLE BEARING	2
252	45-22-0467	SLEEVE	1
253	45-22-0469	SLEEVE	1
254	02-02-0100	BALL	6

FIG.	PART NO.	DESCRIPTION OF PART	QTY.
255	40-50-8900	SPRING	1
256	44-90-0350	RETAINING RING (EXT.)	1
257	48-66-3044	SDS-PLUS ADAPTER	1
259	45-88-1270	WASHER	2
260	45-88-1187	WASHER	1
261	44-10-0077	SHIFT LEVER	1
262	44-66-0101	PLATE	1
264	-----	WASHER	1
★ 265	44-96-0101	ROLLER	4
266	02-02-0110	BALL	4
267	05-77-0030	BOLT	1
268	45-88-1182	WASHER	1
269	45-88-1183	WASHER	1
270	44-90-0115	RING	1
271	45-88-1184	WASHER	1
272	45-88-1185	WASHER	1
273	45-88-1186	WASHER	1
275	05-74-0700	SCREW	2
276	05-74-0717	SCREW	2
415	45-60-0511	BEARING ASSY	1
420	36-66-4267	INTERMEDIATE GEAR SET	1
426	45-88-1170	RETAINING RING	1
427	45-88-1280	WASHER	1
430	45-56-2539	STRIKER ASSEMBLY	1
600	43-46-0172	DEPTH GAGE (NOT SHOWN)	1
701	49-15-5300	SIDE HANDLE (NOT SHOWN)	1
1100	31-44-5359	HANDLE SET	1
1204	34-40-4454	O-RING	1
1207	43-44-0375	GASKET	1
1209	34-40-5359	O-RING	1
1210	34-40-4452	O-RING	1
1211	34-40-4451	O-RING	1
1212	34-40-4459	O-RING	1
1213	34-40-4453	O-RING	1
1214	42-76-0267	QUIK CHANGE COLLAR	1
1215	43-87-0080	ISOLATION BLOCK	1
1218	44-90-4415	RETAINING RING	1
1219	44-90-0350	SNAP RING (EXT.)	1
1220	05-74-0685	SOCKET HEAD SCREW	4
1222	05-74-0695	SOCKET HEAD SCREW	2
1223	05-74-0697	SCREW	2
1224	34-40-0132	O-RING	1
1225	45-06-0215	FELT WASHER	1
1226	38-50-0013	FIXTEC SPINDLE KIT	1

FIG.	PART NO.	DESCRIPTION OF PART	QTY.
4	22-64-0507	CORD SET	1
7	44-60-0015	GROOVED DOWEL PIN	1
100	31-50-0955	MOTOR HOUSING	1
105	18-07-0121	FIELD -SERVICE	1
116	31-05-0220	AIR DEFLECTOR RING	1
117	45-30-0210	SLUG	4
120	22-20-0232	BRUSH HOLDER	2
123	42-70-1100	FIELD CENTERING CLIP	2
125	31-17-0240	CORD CLAMP	1
126	05-78-0720	SCREW	2
127	05-78-0715	SCREW	7
128	23-94-1042	WIRE (BLACK)	1
129	23-94-1037	WIRE (YELLOW)	1
130	42-92-0015	BEARING COVER	1
135	23-66-1687	SWITCH	1
401	31-15-0442	MOTOR COVER	1
406	16-07-0123	ARMATURE - SERVICE	1
407	22-84-0940	FAN	1
408	02-04-1800	BALL BEARING	1
409	02-04-1817	BALL BEARING	1
410	43-06-0135	INSULATING DISC	1
413	45-22-0465	SLEEVE	1
414	45-36-1595	SPACER	1
420	36-66-4267	INTERMEDIATE GEAR SET	1
1100	31-44-5359	HANDLE SET	1
1200	14-46-5360	SERVICE KIT	1
1201	22-18-0942	BRUSH (2) SERVICE KIT	1
1205	42-96-0170	BEARING CUP	1
1208	44-76-0285	STRAIN RELIEF	1
1216	45-30-0220	SLUG	2
1221	05-74-0705	SOCKET HEAD SCREW	4



**SEE BACK PAGE OF THIS BULLETIN
FOR ADDITIONAL LUBRICATION
AND SERVICE NOTES**

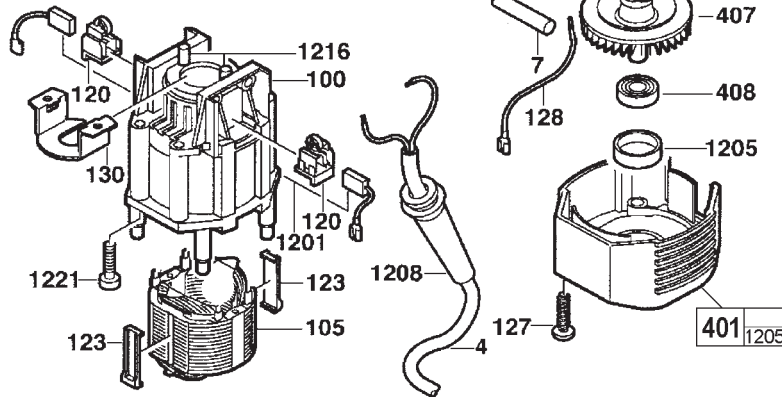

Service Kit 14-46-5360 Contains:

Qty.	Cat. No.	Description	Qty.	Cat. No.	Description
4	05-74-0685	Socket Head Screw	1	42-76-0267	Quik Change Collar
2	05-74-0695	Socket Head Screw	2	42-96-0170	Bearing Cup
2	05-74-0697	Screw	1	43-44-0375	Gasket
4	05-74-0705	Socket Head Screw	1	43-87-0080	Isolation Block
1	22-18-0942	Brush Service Kit (2)	1	44-76-0285	Strain Relief
1	34-40-5359	O-Ring	1	44-90-0375	Snap Ring
1	34-40-0132	O-Ring	1	44-90-4415	Retaining Ring
1	34-40-4451	O-Ring	1	45-06-0215	Felt Washer
1	34-40-4452	O-Ring	2	45-30-0220	Slug
1	34-40-4454	O-Ring	2	45-88-1180	Washers
1	34-40-4453	O-Ring	1	49-08-4250	Type "P" Grease (1.5 oz.)
1	34-40-4459	O-Ring	1	49-08-4255	Type "Q" Grease (1.5 oz.)

Type "P" Grease (Cat. No. 49-08-4250)

1. Place 1/2 oz. at needle bearing / splined retainer area of gear case (200).
2. Grease assembled wobble shaft assembly (211) with 1/2 oz. of grease.
3. Place 1/8 oz. in armature pinion / intermediate shaft assembly (420) cavity.
4. Place 1/4 oz. of grease in wobble shaft drive gear cavity of crankcase (206).
5. Grease clutch (235) and clutch springs (233) on spindle (232) with 1/8 oz. of grease.

NOTE: Total amount used; 1 1/2 oz. (one complete tube)

Type "Q" Grease (Cat. No. 49-08-4255)

1. Coat the spindle (232) inside and out.
2. Coat all parts assembled on or in spindle except for clutch.
3. Coat piston (223) (inside and out), ram (222), wrist pin (224) and wrist pin washers (225). DO NOT coat the flat face of the ram.

NOTE: Total amount used; 3/4 oz. (1/2 of a full tube)

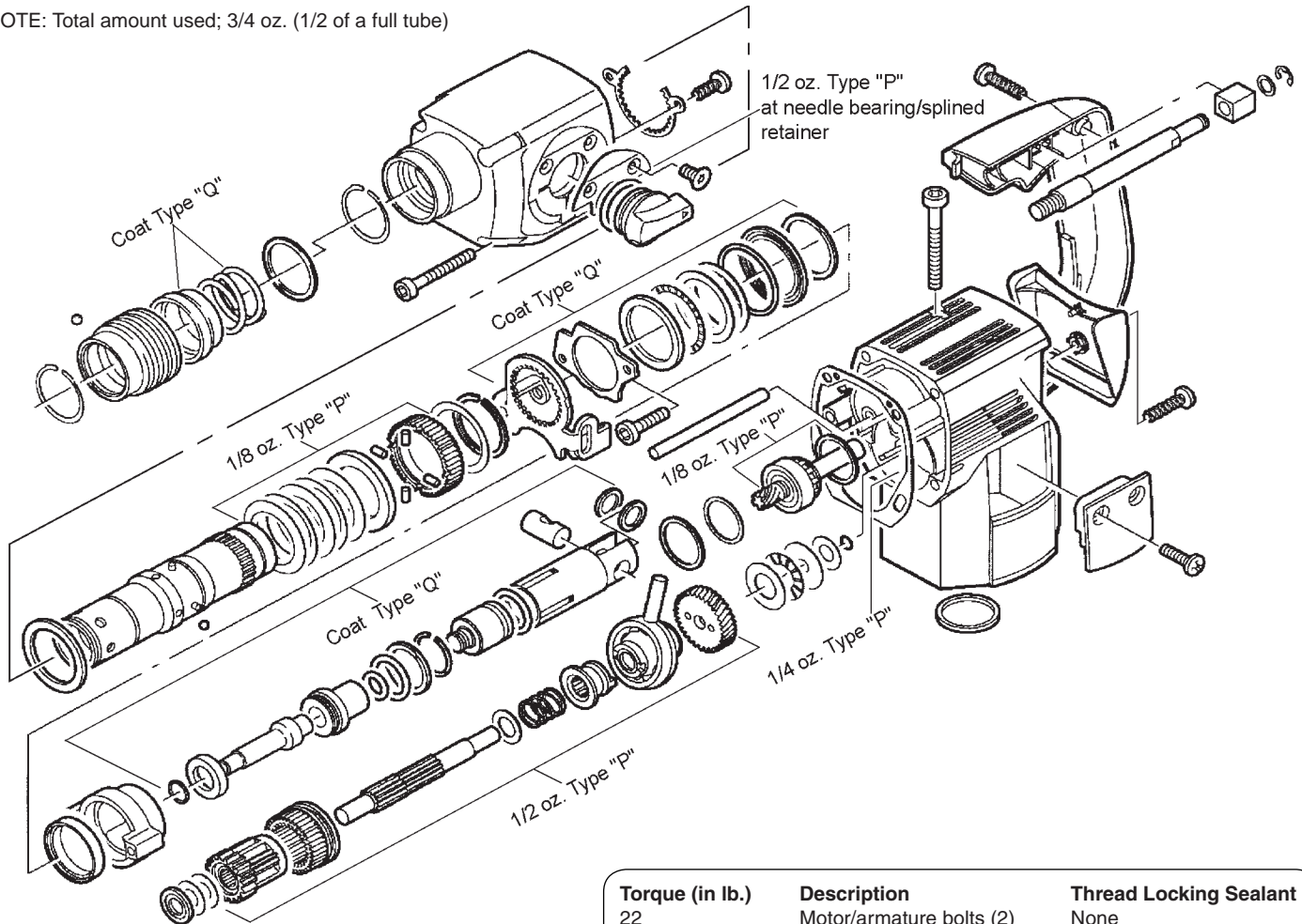

Torque (in lb.)	Description	Thread Locking Sealant
22	Motor/armature bolts (2)	None
22	Motor housing bolts (4)	None
9	Cord Clamp screws (2)	None
85	Anti-vibration post (1)	None
10	Handle screws (3)	None
16	Motor cover screws (4)	None
50	Spindle retaining bolts (2)	Blue
22-26	Gearcase screws (4)	None

SERVICE NOTES:

5360-21

1. To remove the gearcase (200), remove the retaining ring (1219), shift lever (261), plate (262), screws (1220), adapter (257), retainer (1219), collar (1214), balls (254), sleeves (252, 253), spring (255) and washer (256).
2. To remove the spindle (232), the two mounting bolts (275) must be removed with a metric allen wrench.
3. To remove the ram (222), tap the end of the striker assembly (430) with a hammer, this frees the ram from the ram catcher portion of the striker assembly. Ram may be found in piston rather than in ram catcher.
4. To remove the striker assembly (430) from the spindle (232), remove the internal retaining ring (1218) with a small screwdriver by pushing on the ring through the two small ports in the spindle where the ring is visible. Push the ring in and towards the open end of the spindle, use service tool 61-10-0185 if necessary. Press out all internal parts.
5. To remove the rear thrust bearing (238), remove the spiral lock retaining ring (239) with a screwdriver and then remove the thrust bearing.
6. To remove the spindle gear/clutch (235), press the spindle gear against the disk springs (233) and remove the retaining ring (236) that fits into the gear counter bore. NOTE: Washer (264) is no longer being used with new spindle kit.
7. To remove the wobble shaft assembly (211), turn the shaft so the wobble finger of the wobble plate (218) leans toward the motor housing (100). Pull out on the shaft, tilt and wiggle it to get it to clear the crankcase (206).
8. To disassemble the wobble shaft assembly (211), press the reduction gear (219) off, remove all remaining parts.
9. To remove the bearing housing (415), try turning it by twisting on the lugs by hand. If it can be moved, continue to twist and pull to remove. If it will not move, it must be removed with an internal bearing puller.
10. To remove the handle (1100), push out dowel pin (7), open handle, remove snap ring (9) and washer (8) from the isolation block (1215), disconnect field leads under brush covers (102) and remove handle.
11. To remove motor, remove two screws (1222) from the top of the crankcase (206) and 4 screws (1221) from deep pockets in motor housing (100). Slide motor and motor housing out of crankcase.
12. To remove armature (406) from motor assembly, pull brushes (1201) off of commutator, push back brush holders (120) to provide clearance for insulating disc (410), slide bearing cover (130) from under armature ball bearing (409) and slide armature out.
13. When reassembling bearing housing (415) to crankcase (206) do not press it completely into place before the piston (223) and wobble shaft (211) are in place.
14. When reassembling the wobble shaft assembly (211), a clearance of .001 to .003 inch must be maintained between the reduction gear (219) and the inner race of the wobble plate (218). The ground side of the gear must face the wobble plate.
15. When reassembling the clutch be sure to stack the disk springs (233), as shown.
16. Thrust bearing (238) on the spindle (232) must be assembled as shown.
17. To push the internal retaining ring (1218) into the spindle (232) that retains the striker assembly (430), use an old, used piston. The position of the ring can be visually checked by looking in the removal ports.
18. Check slugs (117 and 1216), replace if worn or missing.
19. Bearing cup (1205) to be placed in motor cover (401) before assembly.

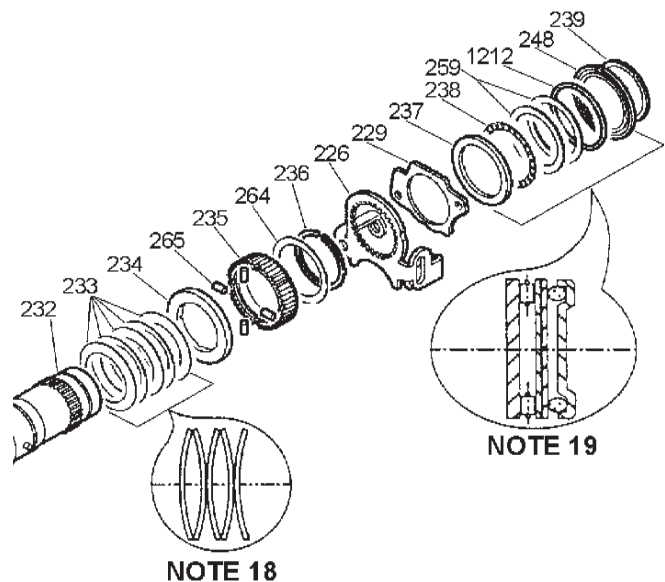
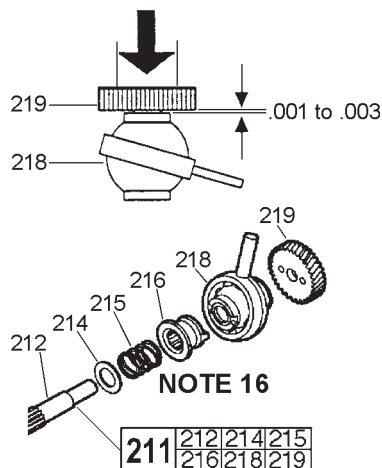

**SEE BACK PAGE OF THIS BULLETIN
FOR ADDITIONAL LUBRICATION
AND SERVICE NOTES**

Service Notes – How to check the Static Slip of Clutch Mechanism

Note! Before checking the 'static' slip clutch torque a tool's clutch assembly must be dynamically slipped for a minimum of 5 seconds; to dynamically slip the clutch assembly requires drilling with the tool and 'binding a bit in the work' and slipping the clutch faces for 5+ SECONDS.

Parts required to check the 'Static Torque' of Slip Clutch of the 5303-20 & 5360-21 Rotary Hammer are as follows.

- Chuck Adapter # 48-03-3047
- ½" - 20 Hex Nut

Checking 'static' torque — 5360-21

- remove SDS chuck adapter # 48-66-3044 from the hammer
- insert the 48-03-3047 chuck adapter with a ½"-20 hex nut threaded onto the adapter
- turn / place shifting lever into the "hammer with rotation mode"
- remove the four (4) screws from the motor cover
- remove the motor cover from the crankcase
- place hammer upside down in a machinist vise and tighten securely
- install ¾" socket onto ft-lbs torque wrench, which corresponds to hex of ½"-20 nut
- hold the armature firm by holding onto the fan
- turn torque wrench in a clockwise direction (as viewed from the bit end of the tool) while holding the armature fan, observe at what value the clutch slips



Service Notes – Disassembling the spindle – Assembling gear reduction shaft

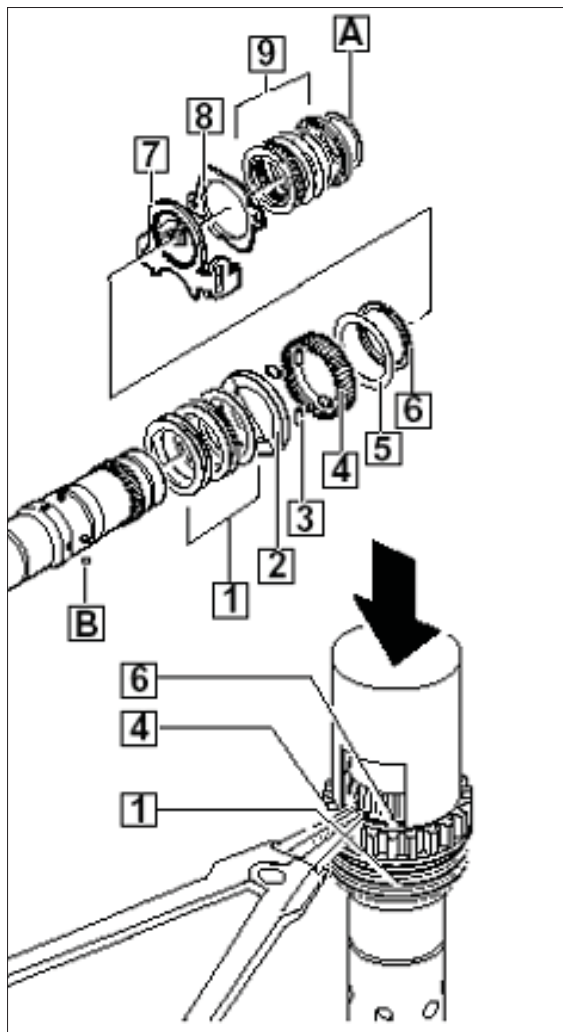

Disassembling the spindle

- 1) remove spiral retaining ring [A]
- 2) remove
 - washer, o-ring, two (2) thin washers, thrust bearing & thick washer assembly [9]
 - retaining plate [8]
 - shift ring [7]
- 3) remove spindle gear [4] with the aid of a 90° external snap ring pliers and 61 30 0290 press fixture (see illustration & Product Support Bulletin #271 & #324) - compress the spindle gear against the belleville spring washers [1] while removing retaining ring [6]
- 4) remove flat washer [5]
- 5) remove four roller pins [3] and stop washer [2]
- 6) remove the four (4) steel balls [B] — compress the five (5) belleville spring washers [1] using 'pipe' press fixture to compress the assembly which will allow for removal of steel balls with the help of a magnetized tip screwdriver - press fixture can be made from 1 3/8" pipe (see illustration below) — failure to use press fixture can cause damage to top belleville spring washer or all belleville spring washers – requiring replacement before re-assembling



Press Fixture for removal of steel balls made from 1 3/8" Black or Galvanized Pipe cutting four [4] notches 90° from each other.

NOTE: Tools having spindle kit 38-50-0013 will not have flat washer #5.

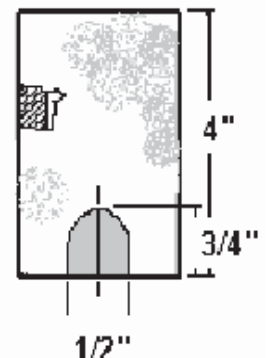
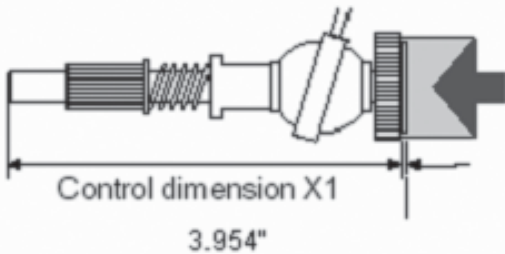
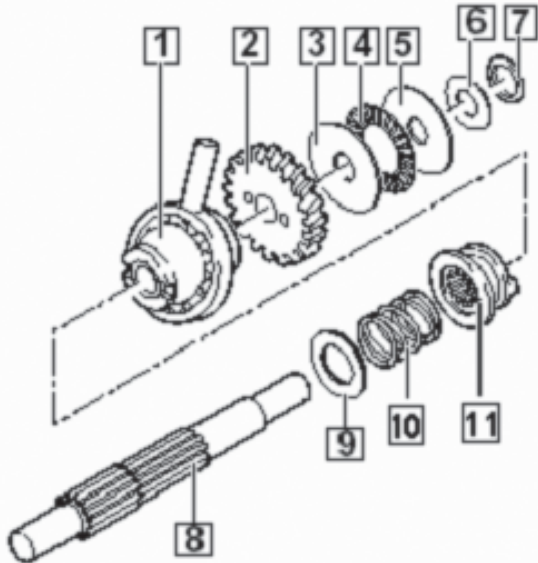

fig 6 is X1 control washer see step 4 to determine if needed



Assembling the reduction gear shaft

1) assemble the reduction gear shaft [8] with the following parts:

- washer [9]
- spring [10]
- coupling sleeve [11]
- wobble plate [1]

2) press reduction gear [2] onto reduction gear shaft [8] with the ground face toward wobble plate; a clearance of 0.001" to 0.003" **must be maintained** between the reduction gear [2] and inner race of the wobble plate [1]

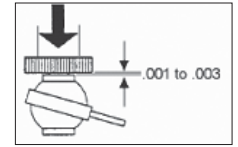

3) lightly **grease entire length of reduction gear shaft** [8] and coupling sleeve [11] - lightly grease the thrust bearing assembly [3,4,&5] and place them onto the shaft

4) check for control dimension X1 of 3.954" to 3.980", if < 3.953" **add a single 45-88-8825 0.020" washer** [6] to the assembly

5) place o-ring [7] on shaft, it serves to hold thrust bearing assembly (and if needed the 0.020" washer) in place

6) assemble internal gear [12], offset gear [13] and 45 88-1182 washer [14] and 45-88-1183 washer [15] onto wobble shaft assembly

7) recess of 45-88-1183 washer [15] must face needle bearing / front of gear case

8) check for control dimension **X2**, if it does not fall between 3.678" – 3.690" chose a suitable washer(s) according to chart and add it (them) to the reduction gear shaft assembly - if required place control washer(s) [16] in front of 45 88-1182 washer [14], sandwiching it (them) between 45 88-1182 washer [14] and 45-88-1183 washer [15]

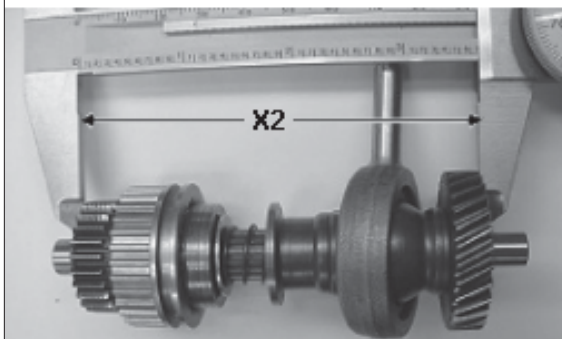

control dimension X2 — 3.678" – 3.690"
measured between face of 45-88-1183 washer [15] & face of flat washer [5], see illustration below
add washer(s) [16] to the assembly as needed to obtain X2 control dimension
most, if not all hammers will require control washer(s)

		control washer(s) [16] added to the assembly as listed		
		0.039" 45-88-1186	0.016" 45-88-1185	0.008" 45-88-1184
control dimension X2				
3.621	3.622	1	-	1
3.622	3.630	1	1	-
3.630	3.638	1	-	1
3.638	3.646	1	-	-
3.646	3.654	-	2	-
3.654	3.661	-	1	1
3.662	3.669	-	1	-
3.670	3.677	-	-	1
3.678	3.690	-	-	-

