

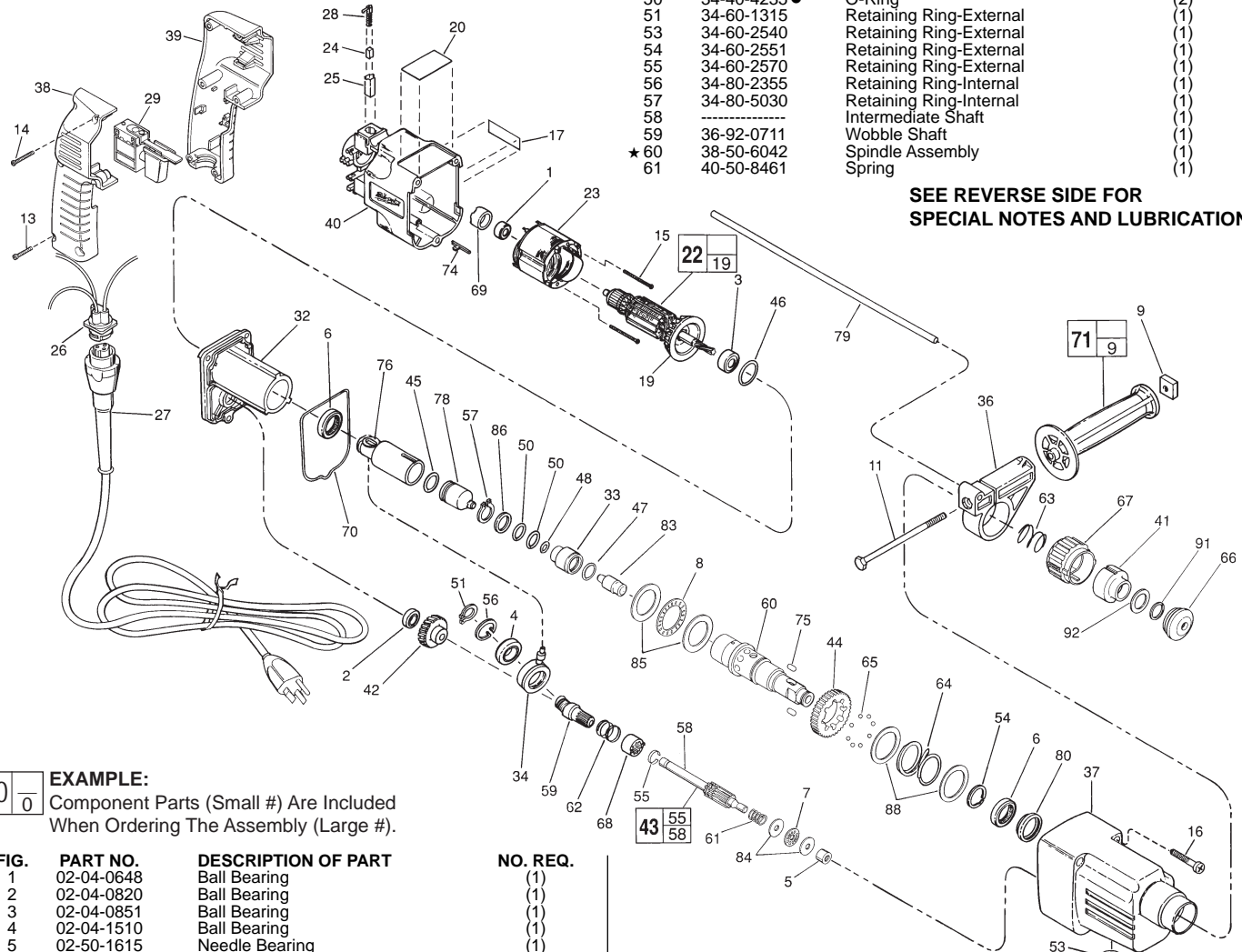

SERVICE PARTS LIST

BULLETIN NO.
54-24-1368

| | | | |
|--|------------------------------|---|-------------------|
| SPECIFY CATALOG NO. AND SERIAL NO. WHEN ORDERING PARTS | | REVISED BULLETIN 54-24-1367 | DATE Jan. 2009 |
| 3/4" ROTARY HAMMER | | | |
| CATALOG NO. 5366-1 | SERIAL NUMBER 794D | WIRING INSTRUCTION 58-01-1315 | |



**SEE REVERSE SIDE FOR
SPECIAL NOTES AND LUBRICATION**

00 0

EXAMPLE:

Component Parts (Small #) Are Included When Ordering The Assembly (Large #).

| FIG. | PART NO. | DESCRIPTION OF PART | NO. REQ. |
|------|------------|---------------------------------------|----------|
| 1 | 02-04-0648 | Ball Bearing | (1) |
| 2 | 02-04-0820 | Ball Bearing | (1) |
| 3 | 02-04-0851 | Ball Bearing | (1) |
| 4 | 02-04-1510 | Ball Bearing | (1) |
| 5 | 02-50-1615 | Needle Bearing | (1) |
| 6 | 02-50-6455 | Needle Bearing | (2) |
| 7 | 02-80-0110 | Thrust Bearing | (1) |
| 8 | 02-80-0121 | Thrust Bearing | (1) |
| 9 | 06-54-0300 | 5/16-18 Square Nut | (1) |
| 10 | 06-65-3690 | 1/8 x 1/2 Groove Pin | (1) |
| 11 | 06-75-5835 | 5/16-18 x 4-1/2" Hex Hd. Bolt | (1) |
| 13 | 06-82-7284 | 8-16 x 3/4" Pan Hd. Slot. Plast. T-20 | (2) |
| 14 | 06-82-7326 | 8-16 x 1" Pan Hd. Slot. Plast. T-20 | (4) |
| 15 | 06-82-7393 | 7-18 x 2" Pan Hd. Slot. Plast. T-20 | (2) |
| 16 | 05-88-5988 | (K50 x 35mm) Pan Hd. Slot. T-20 | (3) |
| 17 | 10-20-1200 | Product Label - Falcon | (1) |
| 19 | 22-84-0650 | Fan Assembly | (1) |
| 20 | 12-20-0120 | Service Nameplate Kit | (1) |
| 22 | 16-10-0660 | 120 V Armature | (1) |
| 23 | 18-11-0140 | 120 V Field | (1) |
| 24 | 22-18-0800 | Brush Service Kit | (1) |
| 25 | 22-20-0810 | Brush Tube | (2) |
| ★ 26 | 22-56-0810 | Pin Housing Assembly | (1) |
| 27 | 48-76-4008 | 8' Quick-Lok Cord | (1) |
| 28 | 23-52-1570 | Brush Spring Assembly | (2) |
| 29 | 23-66-2121 | Switch | (1) |
| 32 | 28-28-2032 | Diaphragm | (1) |
| 33 | 30-37-0050 | Striker Guide | (1) |
| 34 | 30-72-0100 | Wobble Plate | (1) |
| 36 | 31-17-0230 | Handle Ring | (1) |
| 37 | 31-40-0076 | Gear Case | (1) |
| ★ 38 | 31-44-1781 | Right Handle Half | (1) |
| 39 | 31-44-1785 | Left Handle Half | (1) |
| ★ 40 | 31-50-0991 | Motor Housing | (1) |
| ★ 41 | 31-58-0522 | Chuck Sleeve | (1) |
| 42 | 32-40-2230 | Intermediate Gear | (1) |
| 43 | 14-29-0051 | Pinion Shaft Assembly | (1) |
| 44 | 32-10-4080 | Clutch Gear | (1) |
| 45 | 34-40-1215 | O-Ring | (1) |
| 46 | 34-40-2450 | O-Ring | (1) |
| 47 | 34-40-4220 | O-Ring | (2) |
| 48 | 34-40-4225 | O-Ring | (1) |

| FIG. | PART NO. | DESCRIPTION OF PART | NO. REQ. |
|------|------------|-------------------------|----------|
| 50 | 34-40-4235 | O-Ring | (2) |
| 51 | 34-60-1315 | Retaining Ring-External | (1) |
| 53 | 34-60-2540 | Retaining Ring-External | (1) |
| 54 | 34-60-2551 | Retaining Ring-External | (1) |
| 55 | 34-60-2570 | Retaining Ring-External | (1) |
| 56 | 34-80-2355 | Retaining Ring-Internal | (1) |
| 57 | 34-80-5030 | Retaining Ring-Internal | (1) |
| 58 | ----- | Intermediate Shaft | (1) |
| 59 | 36-92-0711 | Wobble Shaft | (1) |
| ★ 60 | 38-50-6042 | Spindle Assembly | (1) |
| 61 | 40-50-8461 | Spring | (1) |

| | | | |
|------|------------|-------------------------|-----|
| 62 | 40-50-8470 | Spring | (1) |
| 63 | 40-50-8481 | Spring | (1) |
| 64 | 40-50-8491 | Spring | (1) |
| 65 | 02-02-1300 | Ball | (8) |
| ★ 66 | 42-76-0672 | Dust Cap | (1) |
| 67 | 42-76-0291 | Chuck Collar | (1) |
| 68 | 42-90-0261 | Coupling | (1) |
| 69 | 42-96-0140 | Bearing Cup | (1) |
| 70 | 43-44-0930 | Gasket | (1) |
| 71 | 43-62-0841 | Side Handle Assembly | (1) |
| 72 | 14-49-0010 | Shift Knob Assembly | (1) |
| 74 | 44-60-0530 | Ground Pin | (1) |
| 75 | 44-60-1150 | Roller Pin | (2) |
| 76 | 14-09-0130 | Piston Assembly | (1) |
| 78 | 44-82-0140 | Ram | (1) |
| 79 | 44-94-0161 | Depth Rod | (1) |
| 80 | 45-06-0560 | Oil Seal | (1) |
| 83 | 45-56-2591 | Striker | (1) |
| ★ 84 | 45-88-8280 | Thrust Washer | (2) |
| 85 | 45-88-8291 | Thrust Washer | (2) |
| 86 | 45-88-8300 | Washer | (1) |
| 87 | 45-88-8310 | Washer | (1) |
| 88 | 45-88-8321 | Washer | (2) |
| 89 | 45-88-8330 | Tab Washer | (1) |
| ★ 91 | 34-60-3680 | Retaining Ring-External | (1) |
| ★ 92 | 45-88-8835 | Washer | (1) |
| | 14-46-5368 | Lubrication Service Kit | (1) |

MILWAUKEE ELECTRIC TOOL CORPORATION
13135 W. LISBON RD., BROOKFIELD, WI 53005
Drwg. 3

SERVICE FIXTURES:

- 61-30-0280 Pressing Tool
- 61-30-0290 Assembly Tool
- 61-40-1110 Bearing Removal

LUBRICATION INSTRUCTIONS

Type "S2" Grease, No. 49-08-5265

Apply a thin film of grease to the following parts as indicated:

- | | |
|-------------|--|
| FIG. | INSTRUCTION |
| 60 | Large I.D. of spindle, forward and rear bearing journals. |
| 33 | Large I.D. of striker guide. |
| 83 | Striker-all over. |
| 76,82 | Inside and outside diameters of piston assembly, including I.D. of socket. |
| 78 | All over ram, except rear face. |
| 59 | Outside bearing journal of wobble shaft. |
| 34 | Bearing bore and ball diameter of wobble plate. |
| 32 | Armature and intermediate bearing bores of diaphragm. |
| 9 | Square nut threads. |
| 45,46,50 | O-rings. |

Apply a thin to moderately heavy coat of grease to the following parts indicated:

- | | |
|-------------|---|
| FIG. | INSTRUCTION |
| 58 | Apply over the length shown in the "Intermediate Shaft Assembly". |
| 75 | Roller Pins (This also to aid in assembly). |
| 47,48 | O-rings. |
| 42,43,44 | All gear and pinion teeth. |

CAUTION: THERE IS TO BE NO GREASE IN THE CHAMBER BETWEEN THE PISTON AND RAM BEYOND THE THIN COATINGS APPLIED TO THE TWO PARTS AS DESCRIBED ABOVE.

▲ **SEE ASSEMBLY LUBRICATION NOTE**

● **14-46-5368 LUBRICATION SERVICE KIT**

THIS KIT INCLUDES:

- | | | |
|---|------------|-------------------|
| 1 | 34-40-1215 | O-Ring |
| 1 | 34-40-4220 | O-Ring |
| 1 | 34-40-4225 | O-Ring |
| 2 | 34-40-4235 | O-Ring |
| 1 | 34-40-2450 | O-Ring |
| 1 | 34-60-3610 | Retaining Ring |
| 1 | 34-60-3680 | Retaining Ring |
| 1 | 34-80-5030 | Retaining Ring |
| 1 | 42-76-0670 | Dust Cap |
| 1 | 42-76-0672 | Dust Cap |
| 1 | 43-44-0930 | Gasket |
| 2 | 44-60-1150 | Roller Pin |
| 1 | 49-08-5265 | 7 Oz. "S2" Grease |

● **22-18-0800 BRUSH SERVICE KIT**

THIS KIT INCLUDES:

- | | | |
|---|------------|--------------------|
| 2 | ----- | Carbon Brush |
| 2 | 23-52-1570 | Brush Spring Assy. |
| 2 | 44-52-0495 | Foam Slug |

Lubrication Note: MILWAUKEE recommends that scheduled maintenance of the Falcon Rotary Hammer include lubrication replacement, and replacement of vital O-rings and gaskets at each carbon brush change. Doing so will prolong the life of the hammer by reducing wear to gears and mechanism parts. The carbon brushes and armature commutator in the MILWAUKEE Falcon Rotary Hammer are designed and matched for many hours of reliable performance. The carbon brushes feature a unique pop-out feature which automatically shuts off the tool when the brushes are worn and need to be replaced.

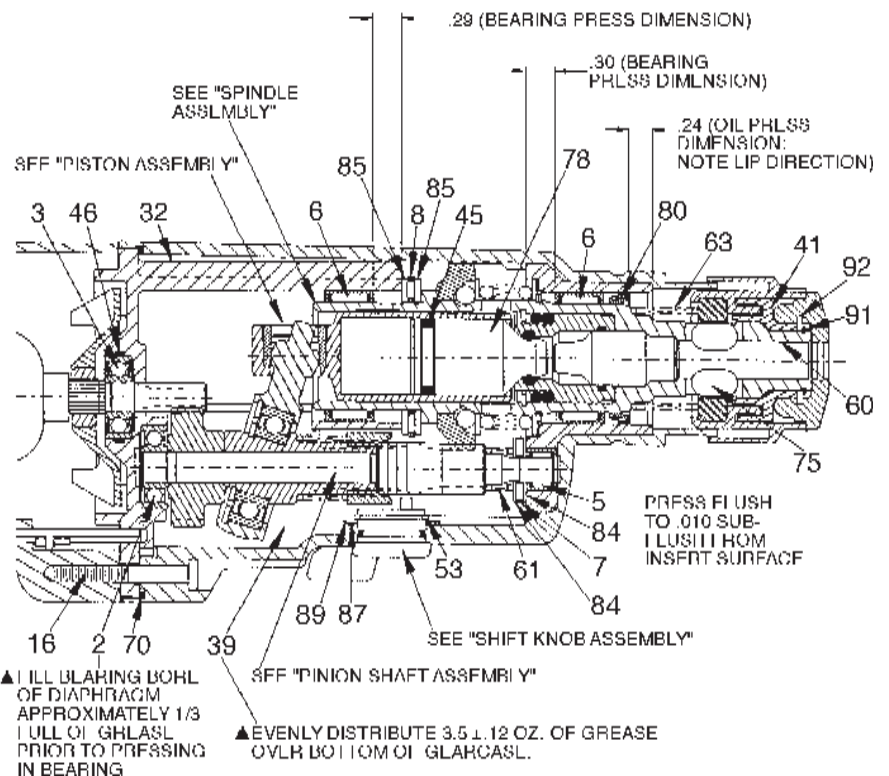

▲ FILL BLARING BOHL OF DIAPHRAGM APPROXIMATELY 1/3 FULL OF GLH LASH PRIOR TO PRESSING IN BEARING

▲ EVENLY DISTRIBUTE 3.5 L. 12 OZ. OF GREASE OVLK BOTTOM OF GLAR CASL.

PRESS TO BOTTOM OF HOLE. (GROOVED END FIRST)

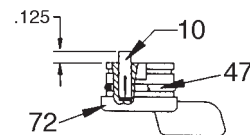

SHIFT KNOB ASSEMBLY

▲ COAT SPINDLE DETENTS WITH GREASE PRIOR TO ASSEMBLING CLUTCH GEAR. PACK CLUTCH GEAR POCKETS WITH GREASE AFTER ASSEMBLING BALLS AND BEFORE ASSEMBLING WASHER. (SEE GENERAL LUBRICATION NOTES)

SHARP EDGE OF RETAINING RING TO BE TOWARD REAR (←) OF SPINDLE

CLUTCH TO BE SLIPPED A MINIMUM OF ONE FULL TURN BOTH CLOCKWISE & COUNTERCLOCKWISE BEFORE ASSEMBLY IS PLACED IN TOOL.

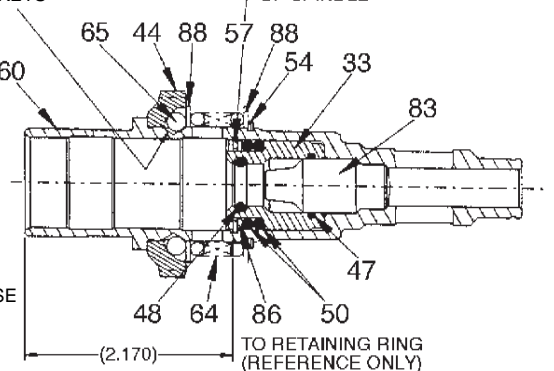

SPINDLE ASSEMBLY

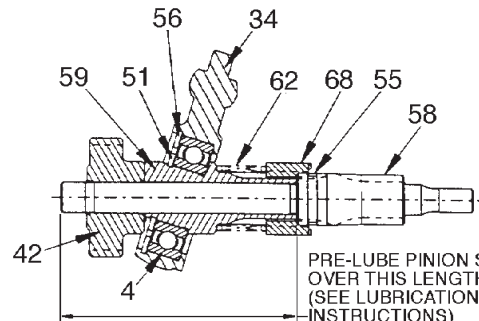

PINION SHAFT ASSEMBLY

NOTE: THE WOBBLE SHAFT #59 AND THE INTERMEDIATE GEAR #42 ARE TO BE PRESSED FLUSH TO EACH OTHER, SO THAT THE WOBBLE SHAFT IS STILL ABLE TO REVOLVE FREELY - WITH .005" MAXIMUM AXIAL PLAY ON THE INTERMEDIATE SHAFT #43.