



SERVICE PARTS LIST

BULLETIN NO.
54-24-3652

SPECIFY CATALOG NO. AND SERIAL NO. WHEN ORDERING PARTS		REVISED BULLETIN	DATE
MAGNUM KEYLESS CHUCK HAMMER DRILL		54-24-3651	May '96
CATALOG NO. 5376-1	STARTING SERIAL NO. 819A	WIRING INSTRUCTION 58-01-1600	

EXAMPLE:
Component Parts (Small #) Are Included
When Ordering The Assembly (Large #).

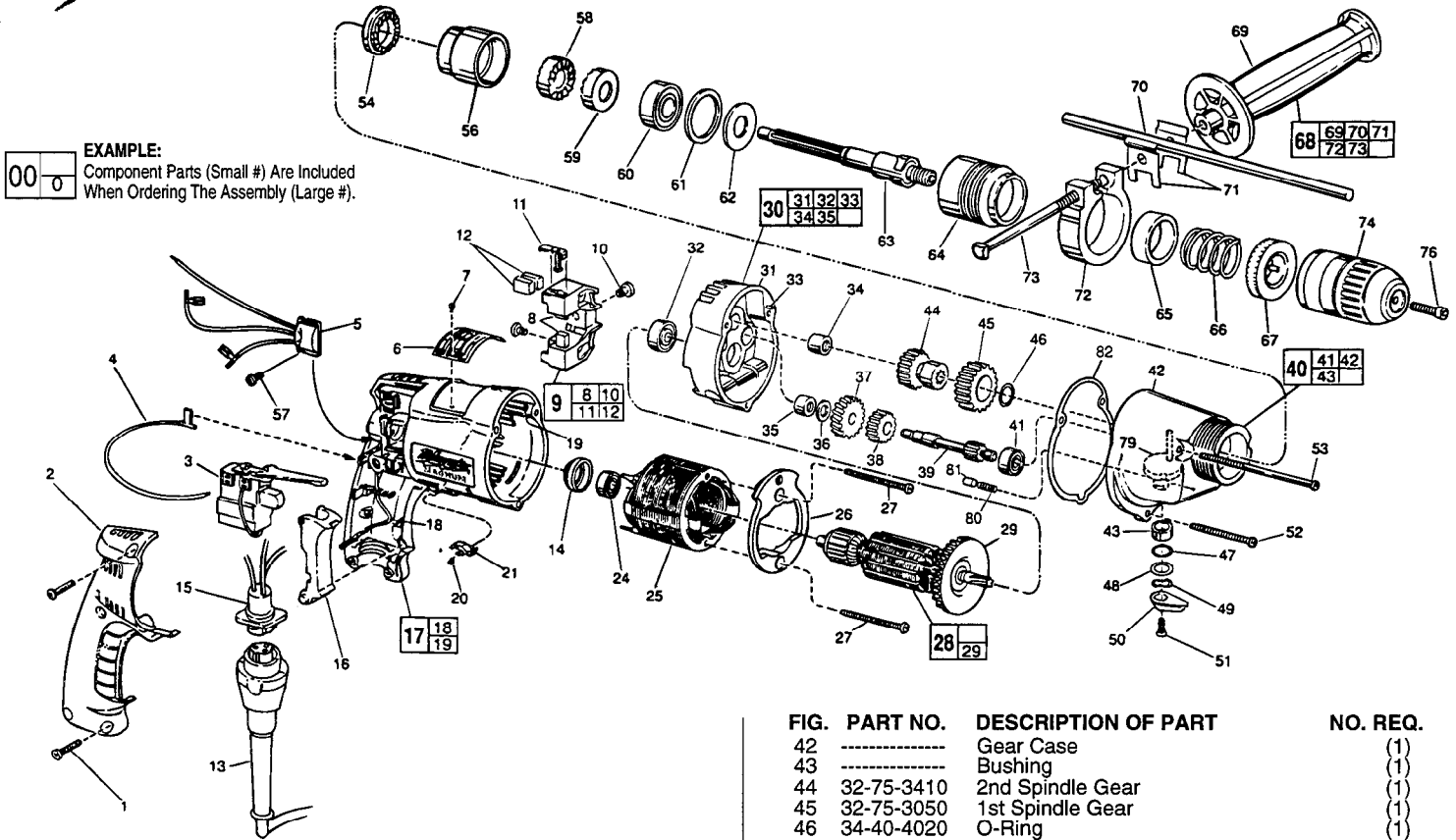

FIG.	PART NO.	DESCRIPTION OF PART	NO. REQ.
1	06-82-7266	7-18 x 11/16" Plastite T-20	(5)
2	31-15-0402	Handle Cover	(1)
3	23-66-1665	Trigger Speed Control Rev. Switch	(1)
4	23-94-6245	2-1/4" Lead Assembly	(1)
5	14-20-0765	Remote Electronic Assembly	(1)
6	12-99-0225	Nameplate Blank	(1)
7	06-72-1720	Nameplate Rivet	(2)
8	22-16-0300	Carbon Brush	(2)
9	22-22-0356	Brush Holder Assembly	(1)
10	31-75-0040	Brush Holder Screw	(2)
11	22-20-0355	Brush Spring Assembly	(2)
12	22-16-0300	Carbon Brush (Spares)	(2)
13	48-76-4008	8 Foot Quik-Lok Cord Set	(1)
14	22-72-0100	Bearing Cup	(1)
15	22-56-0630	Pin Housing Assembly	(1)
16	45-72-0080	Trigger	(1)
17	14-38-0540	Motor Housing Assembly	(1)
18	23-94-9960	Ground Wire Assembly	(1)
19	44-60-1290	Grounding Pin	(1)
20	40-50-0085	Lock Button Spring	(1)
21	42-42-0460	Lock Button	(1)
24	02-04-0645	Ball Bearing	(1)
25	18-11-0075	120 Volt Field	(1)
26	42-14-0390	Baffle	(1)
27	06-82-7398	7-18 x 2-1/16" Pan Hd. Plastite T-20	(2)
28	16-10-0800	120 Volt Armature	(1)
29	22-84-0880	Fan Assembly	(1)
★ 30	14-13-0497	Diaphragm Assembly	(1)
31	-----	Diaphragm	(1)
32	02-04-0847	Ball Bearing	(1)
★ 33	06-65-0880	Ground Pin	(1)
34	02-50-2020	Needle Bearing	(1)
35	02-50-1620	Needle Bearing	(1)
36	45-88-7721	Thrust Washer (Heat Treated)	(1)
37	32-40-1815	Intermediate Gear	(1)
38	32-44-1390	2nd Intermediate Pinion	(1)
39	36-66-1330	1st Intermediate Pinion	(1)
★ 40	14-30-0382	Gear Case Assembly	(1)
41	02-04-0640	Ball Bearing	(1)

FIG.	PART NO.	DESCRIPTION OF PART	NO. REQ.
42	-----	Gear Case	(1)
43	-----	Bushing	(1)
44	32-75-3410	2nd Spindle Gear	(1)
45	32-75-3050	1st Spindle Gear	(1)
46	34-40-4020	O-Ring	(1)
47	34-40-4020	O-Ring	(1)
48	45-88-0250	Washer	(1)
49	45-88-7780	Spring Washer	(1)
50	43-98-0220	Shift Knob	(1)
51	06-81-2502	6-32 x 3/8" Flat Hd. Phil. Screw	(1)
52	06-82-7393	7-18 x 2" Pan Hd. Screw T-20	(1)
53	06-82-7524	7-18 x 3-1/2" Pan Hd. Screw T-20	(2)
54	44-84-0120	Fixed Ratchet	(1)
56	42-52-1010	Bearing Housing	(1)
57	06-82-7212	4-20 x 1/4" Pan Hd. Plastite T-10	(1)
58	44-84-0150	Intermediate Ratchet	(1)
59	44-84-0145	Rotating Ratchet	(1)
60	02-04-1536	Ball Bearing	(1)
61	45-88-7350	Bearing Retainer Washer	(1)
62	45-88-7365	Spring Support Washer	(1)
63	38-50-5295	Spindle	(1)
64	45-22-0405	Sleeve (Left Hand Thread)	(1)
65	45-88-7375	Felt Washer	(1)
66	40-50-4950	Spring	(1)
67	42-76-0200	Locking Collar	(1)
68	14-34-0250	Side Handle Assembly	(1)
69	43-62-0865	Side Handle	(1)
70	44-94-0161	Depth Rod	(1)
71	42-68-0390	Depth Gauge Clamp	(2)
72	25-82-0140	Clamping Collar	(1)
73	42-32-0161	5/16 - 18 x 3-1/2" Square Hd. Bolt	(1)
74	48-66-0600	1/2" Keyless Chuck	(1)
76	06-75-3155	1/4-20 x 1" Socket Hd. Screw - L.H.Thread	(1)
79	42-50-0106	Shift Cam Assembly	(1)
80	40-50-7761	Compression Spring	(1)
81	06-65-3680	Dowel Pin	(1)
★ 82	43-44-0913	Gasket	(1)
	10-98-6070	Caution Label	(1)
	10-98-5986	Caution Label (Omit for Canadian Tools)	(1)

FIG. LUBRICATION
40 2 Oz. Type "E" Grease, No. 49-08-4122.
54,58,59 Apply Thin Coat Type "U" Grease, No. 49-08-0150,
To Ratchet Teeth

MILWAUKEE ELECTRIC TOOL CORPORATION
13135 W. LISBON RD., BROOKFIELD, WI 53005