



SERVICE PARTS LIST

BULLETIN NO.
54-24-0678

SPECIFY CATALOG NO. AND SERIAL NO. WHEN ORDERING PARTS				REVISED BULLETIN	DATE
1/2" HAMMER-DRILL				54-24-0677	Sept. 2006
CATALOG NO.	5378-20	SERIAL NUMBER	897E	WIRING INSTRUCTION 58-01-1151	

EXAMPLE:
00 0

Component Parts (Small #) Are Included When Ordering The Assembly (Large #).

* = Part number change from previous service parts list.

SEE REVERSE SIDE FOR SERVICE & GREASE NOTES

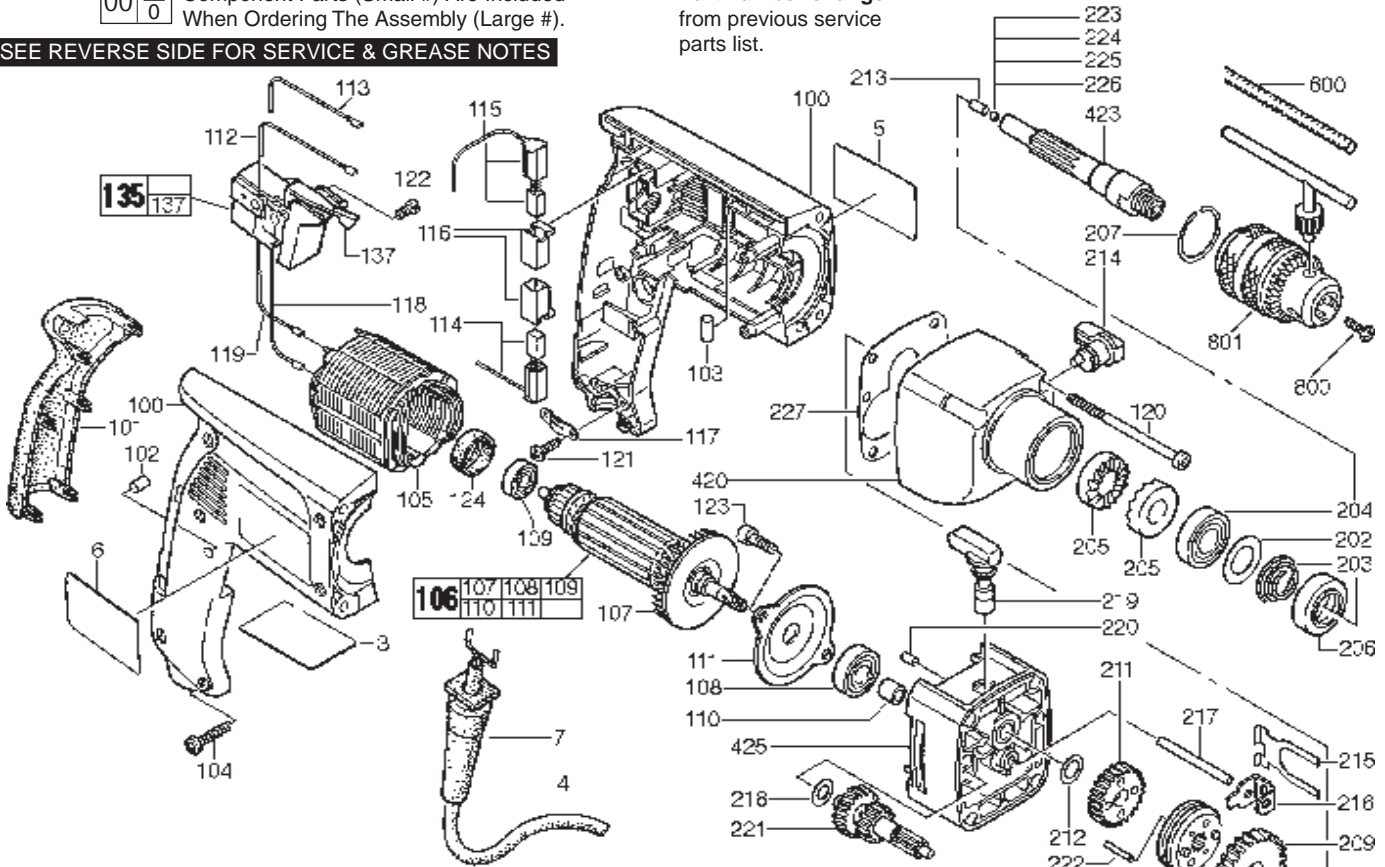

FIG.	PART NO.	DESCRIPTION OF PART	QTY.
3	12-20-0415	Nameplate	1
4	22-64-0515	Cord Set	1
5	10-07-5378	Product Label	1
6	10-07-6225	Warning Label	1
7	44-76-0290	Strain Relief	1
100	14-38-0445	Housing Assembly	1
101	44-52-0585	Handle Cushion	1
102	45-30-0055	Retaining Slug	1
103	45-30-0195	Retaining Slug	1
104	05-78-0715	Screw	2
★ 105	18-07-0155	Service Field	1
★ 106	16-07-0155	Service Armature	1
107	22-84-0930	Fan	1
108	02-04-1825	Ball Bearing	1
109	02-04-1820	Ball Bearing	1
110	42-40-1045	Bushing	1
111	42-92-0070	Bearing Cover	1
112	23-94-1045	Wire	1
113	23-94-1050	Wire	1
114	22-22-0885	Brush Assembly - Lower	1
115	22-22-0890	Brush Assembly - Upper	1
116	22-20-0225	Brush Holder	2
117	31-17-0240	Cord Clamp	1
118	23-94-1055	Wire	1
119	23-94-1060	Wire	1
120	06-82-9640	Screw	4
121	05-78-0720	Screw	2
122	05-81-0932	Screw	1
123	05-81-0960	Screw	2
124	45-22-0540	Rubber Sleeve	1
135	23-66-1692	Switch	1
★ 137	-----	Switch Lever	1
202	45-88-8295	Washer	1
203	40-50-8890	Spring	1
204	02-04-1830	Ball Bearing	1
205	44-84-0295	Ratchet	2
206	44-90-0004	Seal Ring	1
207	44-90-0365	Snap Ring (Int.)	1
208	45-88-1300	Washer	1
209	32-75-1220	Spindle Gear	1

FIG.	PART NO.	DESCRIPTION OF PART	QTY.
210	44-90-4505	Shift Ring	1
211	32-75-1227	Spindle Gear	1
212	45-88-8335	Thrust Washer	1
213	44-60-1490	Pin	1
214	44-10-0095	Shift Lever	1
215	40-50-8355	Retaining Spring	1
216	42-70-0790	Shifting Clip	1
217	44-60-1470	Pin	1
218	45-88-8345	Thrust Washer	1
219	44-10-0105	Shift Lever	1
220	44-60-1500	Pin	1
221	32-60-2637	Reduction Gear	1
222	44-60-1475	Pin	2
223	02-02-0110	Ball (4.0 Diameter)	1
224	02-02-0115	Ball (3.8 Diameter)	1
225	02-02-0125	Ball (3.6 Diameter)	1
226	02-02-0105	Ball (3.4 Diameter)	1
227	43-44-0345	Gasket	1
420	31-40-0020	Gearcase	1
423	38-50-0042	Spindle	1
425	26-28-1865	Diaphragm	1
600	43-46-0172	Depth Gauge	1
800	05-80-0430	Chuck Retaining Screw	1
801	48-66-5185	Chuck	1
	49-15-5300	Side Handle	1
	10-15-0270	Cord Tag	1
	48-66-2110	Chuck Key	1
	48-66-4040	Chuck Key Holder	1

FIG. NOTES:
223-226 The correct size ball must be chosen to properly shim out the end play in the spindle. Spindle is to have a small amount of end play without being tight.

MILWAUKEE ELECTRIC TOOL CORPORATION
13135 W. LISBON RD., BROOKFIELD, WI 53005
Drwg. 2

5378-20 SERVICE AND GREASE NOTES

Service Notes

1. Replace Item (102 and 103) if worn or missing.
2. Grease O-ring on Item (214) before assembly to gear case.

Greasing Instructions

Type "E" (49-08-4122)

1. Coat ratchets with 1/16 oz. of grease.
2. Coat spindle spline, pin (213) and ball (223-226) with 1/16 oz. of grease.
3. Place 1/8 oz. of grease in 1st reduction gear cavity in diaphragm.
4. Grease gear assembly (parts 208, 209, 210, 211, 212, 215, 216, 217, 218, 221 and 222) using 1/4 oz. of grease.

Total amount of grease: 1/2 oz.

