



SERVICE PARTS LIST

BULLETIN NO.
54-38-0287

SPECIFY CATALOG NO. AND SERIAL NO. WHEN ORDERING PARTS		REVISED BULLETIN	DATE
9" SANDER		54-38-0286	June 2006
CATALOG NO.	6072	WIRING INSTRUCTION 58-01-0313	
	SERIAL NUMBER	703D	

00 0

EXAMPLE:

Component Parts (Small #) Are Included When Ordering The Assembly (Large #).

★ = Part number change from previous service parts list.

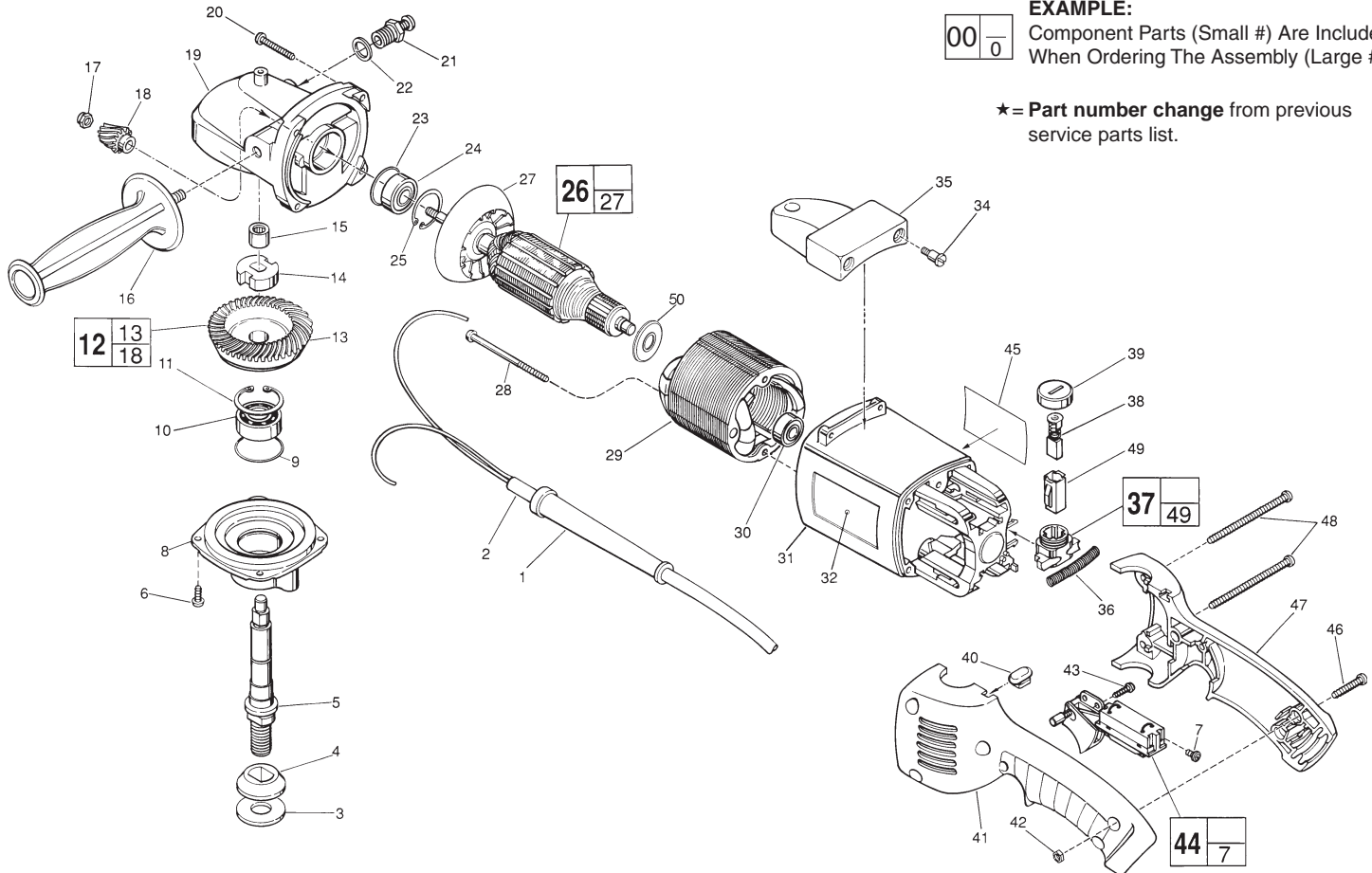

FIG.	PART NO.	DESCRIPTION OF PART	NO REQ.
	1	44-76-0050 Cord Protector	(1)
	2	22-64-0785 Cord Set	(1)
	3	45-88-8465 Spindle Washer	(1)
	4	49-05-0060 Spindle Washer - Flange	(1)
	5	38-50-5645 Spindle Shaft	(1)
	6	06-82-8864 10-24 x 1/2" Pan Hd. Sems T-25 Screw	(4)
★	7	05-78-0305 Switch Screw T-15	(2)
	8	28-14-1900 Lower Gear Case	(1)
	9	34-40-1550 1-9/16" O-Ring	(1)
	10	02-04-1745 Ball Bearing	(1)
	11	34-80-2960 Retaining Ring - Internal	(1)
	12	14-46-4320 Bevel Gear Kit	(1)
	13	32-05-1291 Spiral Bevel Gear	(1)
	14	42-74-0080 Spindle Locking Cog	(1)
	15	02-50-2423 Needle Bearing	(1)
★	16	43-62-1265 Side Handle	(1)
	17	06-57-0500 Lock Nut	(1)
	18	32-60-2201 Spiral Bevel Pinion	(1)
	19	28-14-2090 Upper Gear Case	(1)
	20	06-82-7224 10-14 x 1" Pan Hd. Plastite T-25 Screw	(4)
	21	44-20-0235 Spindle Lock Assembly	(1)
	22	45-88-5320 Flat Washer	(1)
	23	34-40-1375 1-1/4" O-Ring	(1)
★	24	02-04-1860 Ball Bearing	(1)
	25	34-80-2600 Retaining Ring - Internal	(1)
	26	16-50-1185 120 V. Armature	(1)
	27	22-84-0710 Fan	(1)
	28	06-82-7375 8-16 x 2-1/2" Pan Hd. Plastite T-20 Screw	(2)
	29	18-50-0170 120 V. Field	(1)
	30	02-04-0845 Ball Bearing	(1)

FIG.	PART NO.	DESCRIPTION OF PART	NO REQ.
	31	31-50-0548 Motor Housing	(1)
	32	12-20-6105 Service Nameplate Kit	(1)
	34	45-04-0720 Shoulder Screw	(3)
	35	31-70-0140 Tool Rest	(1)
	36	40-50-7770 Brush Holder Spring	(2)
	37	22-22-1325 Brush Holder Assembly	(2)
	38	22-18-0680 Brush Assembly	(2)
	39	23-44-0210 Brush Retaining Screw	(2)
	40	42-38-0190 Bumper	(1)
	41	31-44-1116 Left Handle Half	(1)
	42	06-55-1050 10-24 Hex Nut	(5)
	43	06-82-7409 8-16 x 1/2" Slot. Pan Hd. T-20 Screw	(1)
★	44	23-66-1798 Switch	(1)
	45	10-98-1805 Warning Label	(1)
	46	06-82-2568 10-24 x 7/8" Slot. Pan Hd. T-25 Screw	(3)
	47	31-44-1711 Right Handle Half	(1)
	48	06-82-2598 10-24 x 2-3/4" Slot. Pan Hd. T-25 Screw	(2)
	49	22-20-0660 Brush Tube	(2)
★	50	23-16-1700 Commutator Insulator	(1)

FIG. LUBRICATION:

★ 19 **Important!** Completely clean out old grease from the upper gearcase and replace with 1.5 Oz. Type "Y" Grease, No. 49-08-5270.

FIG. NOTE:

17 Torque To 125-135 In./Lbs.

MILWAUKEE ELECTRIC TOOL CORPORATION
13135 W. LISBON RD., BROOKFIELD, WI 53005