

# EDGE SANDER

## Model 6108

Instruction Manual & Parts List

M-0460222



# **POWERMATIC<sup>®</sup>**

(800) 274-6848  
www.powermatic.com

This manual has been prepared for the owner and operators of a Powermatic Model 6108 Edge Sander. Its purpose, aside from machine operation, is to promote safety through the use of accepted correct operating and maintenance procedures. Completely read the safety and maintenance instructions before operating or servicing the machine. To obtain maximum life and efficiency from your sander, and to aid in using the machine safely, read this manual thoroughly and follow all instructions carefully.

## **Warranty & Service**

The WMH Tool Group warrants every product it sells. If one of our tools needs service or repair, one of our Authorized Repair Stations located throughout the United States can give you quick service.

In most cases, any one of these WMH Tool Group Repair Stations can authorize warranty repair, assist you in obtaining parts, or perform routine maintenance and major repair on your JET, Powermatic, Performax, or Wilton tools.

For the name of an Authorized Repair Station in your area, please call 1-800-274-6848.

## **More Information**

Remember, the WMH Tool Group is consistently adding new products to the line. For complete, up-to-date product information, check with your local WMH Tool Group distributor.

## **WMH Tool Group Warranty**

The WMH Tool Group makes every effort to assure that its products meet high quality and durability standards and warrants to the original retail consumer/purchaser of our products that each product be free from defects in materials and workmanship as follow: 1 YEAR LIMITED WARRANTY ON ALL PRODUCTS UNLESS SPECIFIED OTHERWISE. This Warranty does not apply to defects due directly or indirectly to misuse, abuse, negligence or accidents, normal wear-and-tear, repair or alterations outside our facilities, or to a lack of maintenance.

THE WMH TOOL GROUP LIMITS ALL IMPLIED WARRANTIES TO THE PERIOD SPECIFIED ABOVE, FROM THE DATE THE PRODUCT WAS PURCHASED AT RETAIL. EXCEPT AS STATED HEREIN, ANY IMPLIED WARRANTIES OR MERCHANTABILITY AND FITNESS ARE EXCLUDED. SOME STATES DO NOT ALLOW LIMITATIONS ON HOW LONG THE IMPLIED WARRANTY LASTS, SO THE ABOVE LIMITATION MAY NOT APPLY TO YOU. THE WMH TOOL GROUP SHALL IN NO EVENT BE LIABLE FOR DEATH, INJURIES TO PERSONS OR PROPERTY, OR FOR INCIDENTAL, CONTINGENT, SPECIAL, OR CONSEQUENTIAL DAMAGES ARISING FROM THE USE OF OUR PRODUCTS. SOME STATES DO NOT ALLOW THE EXCLUSION OR LIMITATION OF INCIDENTAL OR CONSEQUENTIAL DAMAGES, SO THE ABOVE LIMITATION OR EXCLUSION MAY NOT APPLY TO YOU.

To take advantage of this warranty, the product or part must be returned for examination, postage prepaid, to an Authorized Repair Station designated by our office. Proof of purchase date and an explanation of the complaint must accompany the merchandise. If our inspection discloses a defect, we will either repair or replace the product, or refund the purchase price if we cannot readily and quickly provide a repair or replacement, if you are willing to accept a refund. We will return repaired product or replacement at WMH's expense, but if it is determined there is no defect, or that the defect resulted from causes not within the scope of WMH's warranty, then the user must bear the cost of storing and returning the product. This warranty gives you specific legal rights; you may also have other rights which vary from state to state.

The WMH Tool Group sells through distributors only. Members of the WMH Tool Group reserve the right to effect at any time, without prior notice, those alterations to parts, fittings, and accessory equipment which they may deem necessary for any reason whatsoever.

# TABLE OF CONTENTS

<b>SAFETY:</b> General Rules .....	4
Specific Rules .....	5
Decal Instruction .....	5
<b>SPECIFICATIONS</b> .....	5
<b>RECEIVING THE SANDER</b> .....	6
<b>INSTALLATION</b> .....	6
Electrical Connections .....	6
<b>OPERATION</b> .....	6
<b>ADJUSTMENTS</b> .....	6
Changing Sanding Belt .....	6
Sanding Belt Tension Spring Fatigue Compensation .....	7
Front Work Table Inclination .....	7
Steel Platen Adjustment .....	8
Motor/Sanding Belt Alignment .....	8
<b>MAINTENANCE</b> .....	9
Lubrication .....	9
Sanding Belt Selection .....	9
<b>TROUBLE SHOOTING</b> .....	10-11
<b>PARTS LIST &amp; EXPLODED VIEW</b> .....	12-13
<b>ELECTRICAL SCHEMATICS</b> .....	14-15
<b>OPTIONAL ACCESSORIES</b> .....	16



## **SAFETY: General Rules**

As with all power tools there is a certain amount of hazard involved with the operation and use of the tool. Use the tool with the respect and caution demanded where safety precautions are concerned. This will considerably lessen the possibility of personal injury. When normal safety precautions are overlooked or completely ignored, personal injury to the operator can result.

1. **KNOW YOUR TOOL.** Read the owner's manual carefully. Learn the tools applications and limitations, as well as the specific potential hazards peculiar to it.

2. **KEEP GUARDS IN PLACE** and maintained in working order.

3. **GROUND ALL TOOLS.** If tool is equipped with three-prong plug, it should be plugged into a three-hole electrical receptacle. If an adapter is used to accommodate a two-prong receptacle, the adapter plug must be attached to a known ground. Never remove the third prong.

4. **REMOVE ADJUSTING KEYS AND WRENCHES.** Form habit of checking to see that keys and adjusting wrenches are removed from tool before turning it on.

5. **KEEP WORK AREA CLEAN.** Cluttered areas and benches invite accidents.

6. **AVOID DANGEROUS ENVIRONMENT.** Don't use power tools in damp or wet locations, or expose them to rain. Keep work area well lighted.

7. **KEEP CHILDREN AND VISITORS AWAY.** All children and visitors should be kept a safe distance from work area.

8. **MAKE WORKSHOP CHILDPROOF** - with padlocks, master switches, or by removing starter keys.

9. **DON'T FORCE TOOL.** It will do the job better and be safer at the rate for which it was designed.

10. **USE RIGHT TOOL.** Don't force tool or attachment to do a job it was not designed for.

11. **WEAR PROPER APPAREL.** Do not wear loose clothing, gloves, neckties, or jewelry that can get caught in moving parts. Nonslip footwear is recommended. Wear protective hair covering to contain long hair.

12. **USE SAFETY GLASSES.** Also use face or dust mask if cutting operation is dusty.

13. **SECURE WORK.** Use clamps or a vise to hold work when practical. It's safer than using your hand and frees both hands to operate tool.

14. **DON'T OVERREACH.** Keep your proper footing and balance at all times.

15. **MAINTAIN TOOLS IN TOP CONDITION.** Keep tools sharp and clean for best and safest performance. Follow instructions for lubricating and changing accessories.

16. **DISCONNECT TOOLS** before servicing and when changing accessories such as chisel and bit.

17. **USE RECOMMENDED ACCESSORIES.** Consult the owner's manual for recommended accessories. The use of improper accessories may cause hazards.

18. **AVOID ACCIDENTAL STARTING.** Make sure switch is in "OFF" position before plugging in cord.

19. **NEVER STAND ON TOOL.** Serious injury could occur if the tool is tipped or if the cutting tool is accidentally contacted.

20. **CHECK DAMAGED PARTS.** Before further use of the tool, a guard or other part that is damaged should be carefully checked to ensure that it will operate properly and perform its intended function - check for alignment of moving parts, binding of moving parts, breakage of parts, mounting, and any other conditions that may affect its operation. A guard or other part that is damaged should be properly repaired or replaced.

21. **NEVER LEAVE TOOL RUNNING UNATTENDED. TURN POWER OFF.** Don't leave tool until it comes to a complete stop.

22. **DRUGS, ALCOHOL, MEDICATION.** Do not operate tool while under the influence of drugs, alcohol, or any medication.

23. **ADDITIONAL HEALTH HAZARDS.** Some dust created by power sanding, sawing, grinding, drilling and other construction activities contains chemicals known to cause cancer, birth defects or other reproductive harm. Some examples of these chemicals are:

- \* Lead from lead-based paint.
- \* Crystalline silica from bricks and cement and other masonry products
- \* Arsenic and chromium from chemically-treated lumber.

Your risk from these exposures varies, depending on how often you do this type of work. To reduce your exposure to these chemicals, work in a well-ventilated area, and work with approved safety equipment, such as those dust masks that are specifically designed to filter out microscopic particles.



### SAFETY: Specific Rules

1. Before you turn on the machine, make sure everyone is clear of it. Keep hands away from abrasive belt.
2. Never remove safety guards during operation.
3. Make sure the abrasive belt is not torn or loose.
4. Make sure the direction of rotation is the same as that marked on the machine label. If not, the power connection must be changed.

5. Make sure the abrasive belt is tracking properly.
6. Support your workpiece with the work table.
7. When front work table is to be used at an incline, check that the work table is firmly fixed on the machine.
8. Sand with the grain of the wood.
9. Hold the workpiece firmly, to prevent it being driven from your hands.
10. Feed workpiece against rotation of abrasive belt.
11. Do not put excess pressure on the abrasive belt. It is not necessary and will only lead to damage to the belt or the workpiece.



### SAFETY: Decal Instruction

## SAFETY RULES

CAREFULLY READ INSTRUCTION MANUAL BEFORE OPERATING MACHINE.

DO NOT OPERATE WITHOUT ALL GUARDS AND COVERS IN POSITION.

BE SURE MACHINE IS ELECTRICALLY GROUNDED.

REMOVE OR FASTEN LOOSE ARTICLES OF CLOTHING SUCH AS NECKTIES, ETC. CONFINE HAIR.

USE SAFETY FACE SHIELD, GOGGLES, OR GLASSES TO PROTECT EYES AND OTHER PERSONAL SAFETY EQUIPMENT AS REQUIRED.

STOP MACHINE BEFORE MAKING ADJUSTMENTS OR CLEANING CHIPS FROM WORK AREA.

KEEP THE FLOOR AROUND THE MACHINE CLEAN AND FREE FROM SCRAPS, SAWDUST, OIL OR GREASE TO MINIMIZE THE DANGER OF SLIPPING.

## SPECIFICATIONS (6108 Edge Sander)

Sanding belt size .....	6" x 108"
Front table .....	37" x 7-3/4"
Side table .....	19" x 12"
Dust chute .....	4" dia.
Belt speed .....	3,150 SFPM
Overall dimensions .....	64-1/2" L x 23" W x 43-1/4" H
Motor .....	1-1/2 HP, 1 Ph, 115/230V (prewired 115V) 2 HP, 3 Ph, 230/460V (prewired 230V)
Drive wheel .....	7" O.D. x 6"
Net weight .....	491 lbs.

## RECEIVING THE SANDER

Remove sander from its crate. Check for damage and ensure all parts are intact. Any damage should be reported immediately to your distributor and shipping agent. Before assembling, read the manual thoroughly, familiarizing yourself with correct assembly and maintenance procedures and proper safety precautions.

### Contents:

- 1 Sander
- 2 Work tables
- 1 Dust chute
- 1 Steel platen
- 1 Hardware bag containing 1 phillips screwdriver, 1 open-end wrench, 4 allen wrenches

## INSTALLATION

Remove the bolts securing the sander to the shipping base. Install the machine on firm, level ground with 5/16" lag bolts through the holes in the bottom of the base. Use shims if necessary to level the machine before tightening the lag bolts.

Remove any protective coating from exposed metal surfaces with a soft cloth moistened with a good commercial solvent. DO NOT use acetone, gasoline, lacquer thinner or any type of flammable solvent. Do not use solvents on plastic parts.

## ELECTRICAL CONNECTIONS

Wire the sander to a grounded, metal-enclosed wiring system in accordance with the requirements of the National Electric Code (ANSI/NFPA70).

**⚠ WARNING:** ELECTRICAL WIRING SHOULD BE DONE BY A QUALIFIED ELECTRICIAN. THE MACHINE MUST BE PROPERLY GROUNDED TO HELP AVOID ELECTRIC SHOCK AND ASSOCIATED HAZARDS INCLUDING POSSIBLE DEATH.

If your edge sander is 3-phase, there is a four conductor power source cable. If single-phase, it has a three conductor power source cable. On both models, the ground conductor is green or yellow & green. NEVER connect the green wire to a live terminal.

## OPERATION

The sander is equipped with a push-button magnetic control system.

When starting the machine, make sure the rotational direction is correct. If it is not, the power connection will have to be changed: If 3-phase, change any two

of the three power leads. If single-phase, check the motor connection (refer to wiring diagram in connection box.)

## ADJUSTMENTS

**⚠ CAUTION:** Disconnect sander from power source before making adjustments.

## CHANGING SANDING BELT

1. Loosen the two latches (A), on the dust chute, and open the dust hood, Figure 1.
2. Remove the sanding belt safety guard (B) by removing the two knobs (C) which are on the guard.

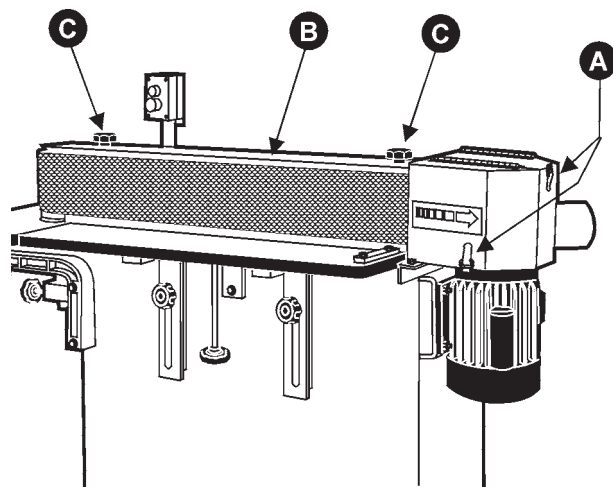

FIGURE 1

3. Rotate the sanding belt tension adjustment knob (D) clockwise to release idler pulley device (E). See Figure 2. Remove the old belt.

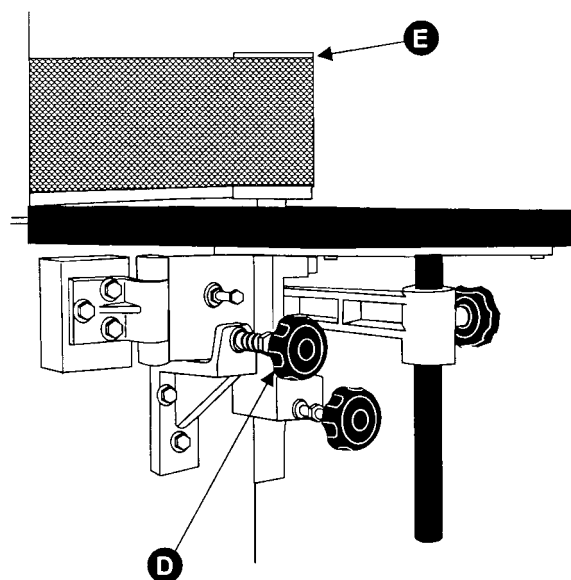
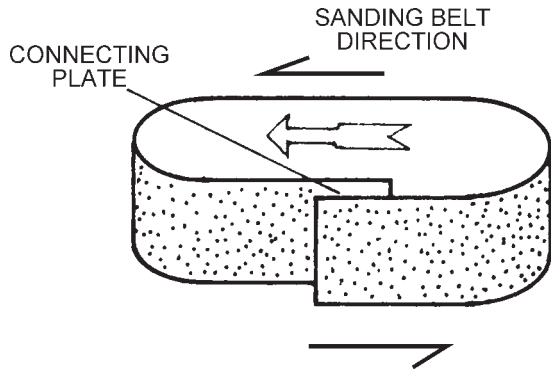

FIGURE 2

**NOTE:** Identify the sanding belt direction before you install the belt, because the belt's rotational direction must be the same as the machine. An arrow on the reverse side of the belt shows the proper direction and should match the arrow direction on the machine guard. If the belt has no arrow indicator, find the joint of the belt (where it is layered) and install it according to Figure 3.



**FIGURE 3**

4. Place the new sanding belt between the contact wheel and idler pulley, then adjust the tension adjustment knob (D). Counterclockwise will maximize the tension, clockwise will minimize it.

5. Check that the new belt is tracking correctly by rotating it with one hand, Figure 4, and use your other hand to make any adjustments to the track adjustment knob (F). To lower the abrasive belt, rotate the track adjustment knob clockwise. To raise it, rotate counterclockwise.

**NOTE:** The track adjustment mechanism is very sensitive - make these corrections gently.

When properly adjusted, the sanding belt should keep the same steady level during rotation without moving too high or too low.

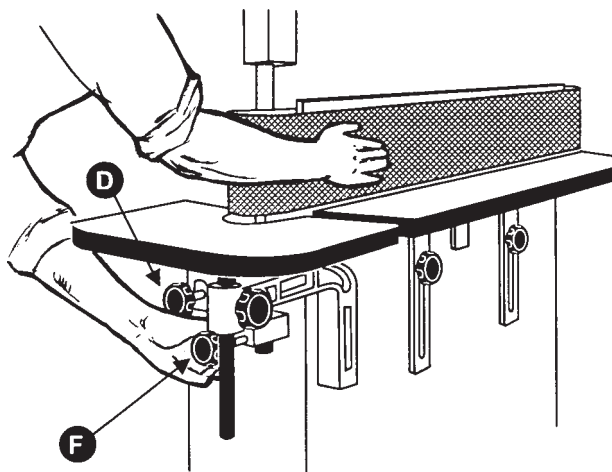

**FIGURE 4**

6. Replace safety guard (B), close dust hood and re-tighten knobs (A).

7. Turn machine on and off quickly several times to check that the sanding belt rotation is normal and that it tracks properly. If not, repeat the above procedure.

## SANDING BELT TENSION SPRING FATIGUE COMPENSATION

Adjustment of the sanding belt will cause spring fatigue when used for a long period. If this happens, it's not necessary to change the spring. Simply rotate the tension adjustment screw (A), Figure 5, clockwise until you achieve the proper tension compensation.

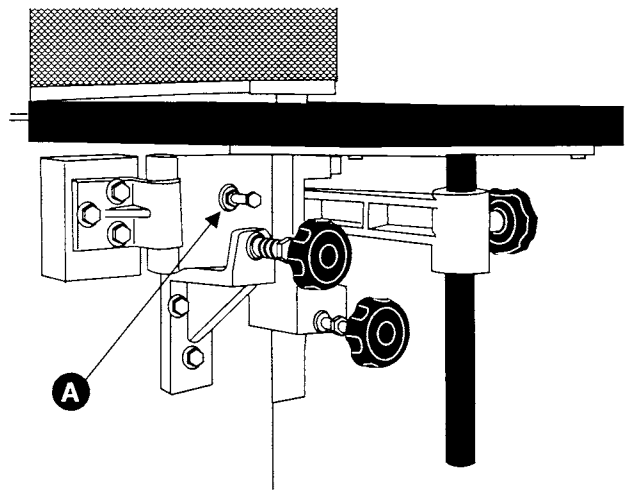

**FIGURE 5**

## FRONT WORK TABLE INCLINATION

Using the inclined table method on this edge sander may give you better sanding surface contact, decreased sanding marks and burr residue, with results equal to that of an oscillating sanding machine. To adjust the front work table:

1. Loosen the two fixed knobs (A), Figure 6.
2. Raise the front work table (B) by rotating the adjustment knob (C) and incline it to the degree desired.
3. Re-tighten the fixed knobs (A).

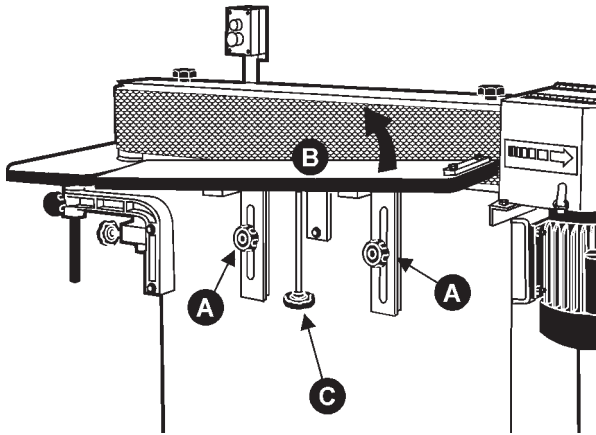

FIGURE 6

## STEEL PLATEN ADJUSTMENT

The steel platen is located between the motor contact wheel and the idler pulley. The surface of the steel platen should protrude about 1/8" - 1/4" past the motor contact wheel and the idler pulley in order to assure that the sanding belt will be in contact totally with the steel platen.

Adjust as follows:

1. Remove sanding belt (refer to "Changing Sanding Belt").
2. Loosen the two fixed screws (A), Figure 7, on the steel platen at the rear of the machine.

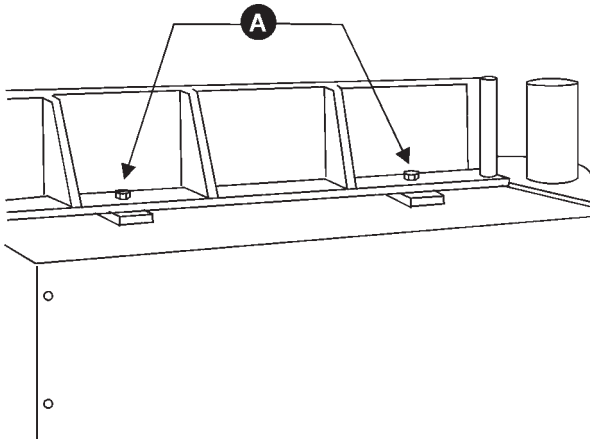

FIGURE 7

3. Using a straight edge (B), to measure the protruding distance between the surface of the steel platen and the two pulleys (i.e. motor contact wheel & idler pulley). See Figure 8.
4. Tap the steel platen with your hand until the protruding distance is 1/8" to 1/4". The platen/motor contact wheel & platen/idler pulley distances should be the same.
5. Re-tighten the fixed screws (A) on the platen, and replace sanding belt.

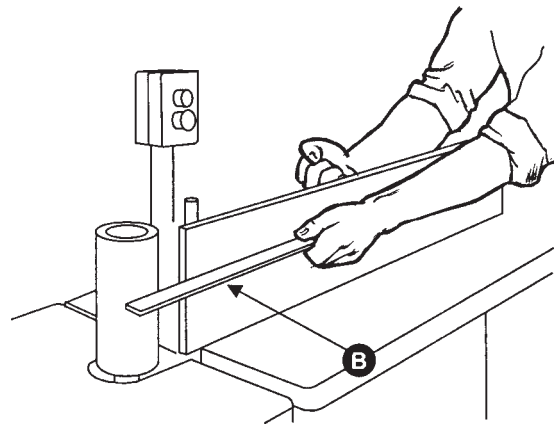

FIGURE 8

## MOTOR/SANDING BELT ALIGNMENT

The motor and sanding belt on the edge sander were factory aligned. However, if they are out of alignment due to shipping, adjust as follows:

1. Adjust front work table to its lowest position.
2. Loosen the two fixed screws on the dust chute and remove chute from machine.
3. Remove safety guard.
4. Rotate the belt by hand to ensure that it is completely parallel with the steel platen, top left to top right. Use a straight edge if necessary to measure this.
5. If the sanding belt left to right is not parallel with the steel platen, then the motor is not adjusted properly. Loosen the motor mounting screws (A), Figure 9, and adjust with the two jack screws (B).

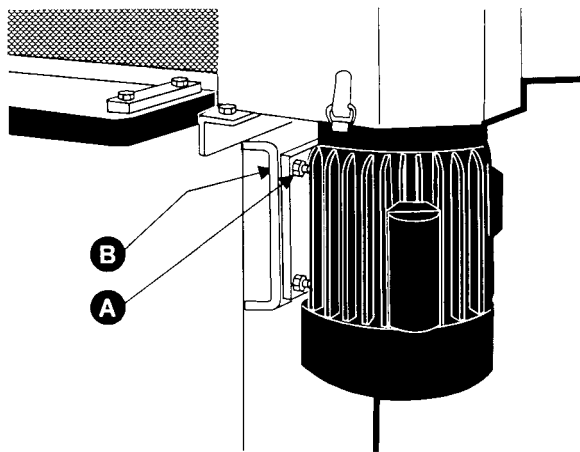

FIGURE 9

6. If the right side of the sanding belt (near the motor) is too high, adjust motor inclination inward, until the sanding belt is parallel with the steel platen. Then tighten the four motor fixed screws (E).
7. Rotate the sanding belt by hand again to make sure it is completely parallel with steel platen.
8. Replace safety guard and dust hood, and adjust the sanding belt tracking if necessary.



## MAINTENANCE

### LUBRICATION

**⚠ CAUTION:** Disconnect sander from power source before performing maintenance.

Do not operate the sander until it is properly lubricated.

All ball bearings are sealed for life and do not require lubrication.

Apply a drop of light machine oil occasionally on the hinge of the tension mechanisms as shown in Figure 10. Service the machine every 6 weeks.

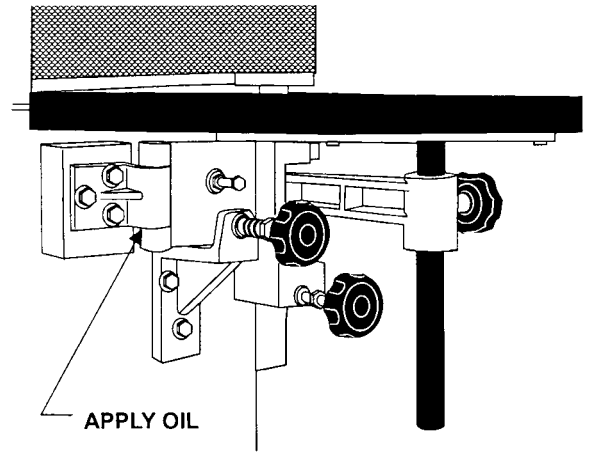

**FIGURE 10**

### SANDING BELT SELECTION

Use the chart, Figure 11, for selecting an abrasive belt. Aluminum oxide is recommended for general use in the home workshop.

Figure 12 groups abrasives into five classes, indicating the grit numbers that fall into each.

ABRASIVE	USE	COARSE	GRIT MEDIUM	FINE
Aluminum Oxide	Hardwood	30-40	60-80	100-120
	Aluminum	40	60-80	100
	Copper	40-50	80-100	100-120
	Steel	24-30	60-80	100
	Ivory	60-80	100-120	120-280
	Plastic	50-80	120-180	240

**FIGURE 11**

TYPE	VERY FINE	FINE	MEDIUM	COARSE	VERY COARSE
Aluminum Oxide	220-360	120-180	80-100	40-60	24-36

**FIGURE 12**

## TROUBLE SHOOTING

PROBLEM	POSSIBLE CAUSE	SOLUTION
Sander will not start.	<ol style="list-style-type: none"> <li>1. Fuse blown or circuit breaker tripped.</li> <li>2. Cord damaged.</li> </ol>	<ol style="list-style-type: none"> <li>1. Replace fuse or reset circuit breaker.</li> <li>2. Have cord replaced by qualified electrician.</li> </ol>
Overload kicks out frequently.	<ol style="list-style-type: none"> <li>1. Extension cord too light or too long.</li> <li>2. Excessive bite or feed pressure too great.</li> <li>3. Motor not wired for correct voltage.</li> </ol>	<ol style="list-style-type: none"> <li>1. Replace with adequate size cord.</li> <li>2. Allow sanding belt to cut freely - do not force.</li> <li>3. Refer to motor name plate for correct wiring.</li> </ol>
Sanding belt does not come up to speed.	<ol style="list-style-type: none"> <li>1. Extension cord too light or too long.</li> <li>2. Low (house) current.</li> <li>3. Motor not wired for correct voltage.</li> <li>4. Excessive bite or feed pressure too great.</li> </ol>	<ol style="list-style-type: none"> <li>1. Replace with adequate size cord.</li> <li>2. Contact a qualified electrician.</li> <li>3. Refer to motor name plate for correct wiring.</li> <li>4. Allow abrasive belt to cut freely - do not force.</li> </ol>
Machine vibrates excessively.	<ol style="list-style-type: none"> <li>1. Stand or bench on uneven floor.</li> <li>2. Improper motor mounting.</li> <li>3. Sanding belt not tensioned correctly.</li> <li>4. The spring for tension mechanism is fatigued or broken.</li> <li>5. Contact wheel is too loose.</li> <li>6. Sanding belt broken.</li> <li>7. Bad sanding belt.</li> </ol>	<ol style="list-style-type: none"> <li>1. Reposition on flat level surface. Fasten to floor if necessary.</li> <li>2. Check and adjust motor mounting.</li> <li>3. Tensioning of belt is accomplished through the knob that controls the spring. Make sure knob is released so the full tension of the spring is working.</li> <li>4. Replace with new spring.</li> <li>5. Tighten cap screw in motor shaft.</li> <li>6. Replace with new sanding belt.</li> <li>7. Replace with new sanding belt.</li> </ol>
Inadequate job on metal.	<ol style="list-style-type: none"> <li>1. Wrong sanding belt.</li> </ol>	<ol style="list-style-type: none"> <li>1. Use aluminum oxide or silicon carbide sanding belts, not flint or garnet.</li> </ol>
Sanding marks on work.	<ol style="list-style-type: none"> <li>1. Sanding belt too coarse for finish required.</li> <li>2. Wrong sanding belt grit.</li> <li>3. Work sanded across grain.</li> </ol>	<ol style="list-style-type: none"> <li>1. Use very fine sanding belt for final finish.</li> <li>2. Use coarser grit for stock removal.</li> <li>3. When surface sanding, use very fine sanding belt then finish by hand, working in direction of grain.</li> </ol>
Sanding grains quickly rub off belt.	<ol style="list-style-type: none"> <li>1. Sanding belt has lost its original properties.</li> <li>2. Incorrect storage.</li> </ol>	<ol style="list-style-type: none"> <li>1. Do not store sanding belts where it is extremely dry or where temperatures are extremely high.</li> <li>2. Store sanding belt properly. Do not fold it.</li> </ol>

## TROUBLE SHOOTING (continued)

PROBLEM	POSSIBLE CAUSE	SOLUTION
Sanding belt glazes.	<ol style="list-style-type: none"> <li>1. Sanding painted surface.</li> <li>2. Wood is wet or gummy.</li> </ol>	<ol style="list-style-type: none"> <li>1. Use open-end grain/flint belt.</li> <li>2. No cure. Use different stock.</li> </ol>
Work burns.	<ol style="list-style-type: none"> <li>1. Wrong sanding belt surface.</li> <li>2. Feed pressure too great.</li> <li>3. Work held motionless.</li> </ol>	<ol style="list-style-type: none"> <li>1. Use coarser grit for stock removal.</li> <li>2. Never force work into steel platen.</li> <li>3. Keep work moving.</li> </ol>
Sanding marks on work.	<ol style="list-style-type: none"> <li>1. Work held motionless.</li> </ol>	<ol style="list-style-type: none"> <li>1. Keep work moving.</li> </ol>
Sanding belt burns, clogs quickly on thickness sanding.	<ol style="list-style-type: none"> <li>1. Biting too deep.</li> </ol>	<ol style="list-style-type: none"> <li>1. Adjust for slight sanding action and make repeated passes.</li> </ol>
Indentations in work.	<ol style="list-style-type: none"> <li>1. Work held motionless in one spot.</li> </ol>	<ol style="list-style-type: none"> <li>1. Keep work moving.</li> </ol>
Sanding end idler pulley distorts.	<ol style="list-style-type: none"> <li>1. Excessive bite or feed pressure.</li> </ol>	<ol style="list-style-type: none"> <li>1. Allow sanding belt to sand freely, do not force.</li> </ol>
Work pulled from hand.	<ol style="list-style-type: none"> <li>1. No support.</li> </ol>	<ol style="list-style-type: none"> <li>1. Use the work stop on the front table.</li> </ol>
Sanding belt has broken at the joint.	<ol style="list-style-type: none"> <li>1. Belt running in wrong direction.</li> </ol>	<ol style="list-style-type: none"> <li>1. Match rotation direction with arrow on machine guard.</li> </ol>
Sanded edge not square.	<ol style="list-style-type: none"> <li>1. Result of freehand sanding.</li> <li>2. Table misaligned.</li> </ol>	<ol style="list-style-type: none"> <li>1. Keep work piece flat on table at all times when a square edge is desired.</li> <li>2. Check table alignment to steel platen. It should be 90 degrees. Adjust accordingly.</li> </ol>
Sanding belt has bevel.	<ol style="list-style-type: none"> <li>1. Motor misaligned.</li> </ol>	<ol style="list-style-type: none"> <li>1. Adjust motor alignment.</li> </ol>
Sanding belt has dropped while sanding.	<ol style="list-style-type: none"> <li>1. Sanding belt not tensioned correctly.</li> <li>2. Tension mechanism spring is fatigued or broken.</li> <li>3. Sanding belt not tracking correctly.</li> </ol>	<ol style="list-style-type: none"> <li>1. Adjust sanding belt tension with knob.</li> <li>2. Replace with new spring.</li> <li>3. Adjust tracking.</li> </ol>
Sander sanding unsatisfactorily.	<ol style="list-style-type: none"> <li>1. Incorrect positioning of steel platen.</li> </ol>	<ol style="list-style-type: none"> <li>1. Adjust steel platen 1/8" to 1/4" above the contact wheel and idler pulley.</li> </ol>

## PARTS LIST: Model 6108 Edge Sander

NO.	PART NO.	DESCRIPTION	NO.	PART NO.	DESCRIPTION
1	6294030	TABLE, END	48	6294075	WASHER, 5/16"
4	6294031	PLATE, STEEL END	49	6294076	COVER, BACK
5	6294032	SCREW, HEX. HD. WOOD, 1/4-20 X 1-1/4	50	6294077	SCREW, WING, 1/4-20 X 5/8"
6	6294033	BAR, SUPPORT	51	6294078	PIECE, CLAMPING
7	6294034	SUPPORT, TABLE	52	6294079	SCREW, SOC. HD. CAP, 5/16-18 X 1"
8	6294035	KNOB	53	6294080	WHEEL, CONTACT
9	6294036	WASHER, 3/8"	54	6294081	SCREW, HEX HD., 1/2-12 X 2-1/2"
10	6294037	SCREW, HEX HD. 3/8-16 X 1-1/2"	55	6294082	NUT, HEX 1/2"
11	6294038	KNOB	56	6294083	SCREW, SET, 5/16-18 X 3/8"
12	6294039	NUT, WING	57	6294084	MOTOR, 2 HP, 3 PH
13	6294040	HOLDER, SPRING		6294085	MOTOR, 1-1/2 HP, 1 PH
14	6294041	SCREW, HEX HD. 3/8-16 X 1-5/8"	58	6294086	KEY
15	6294042	NUT, HEX 3/8	59	6294087	HOOD, DUST
16	6294043	SPRING	60	6294088	ASSEMBLY, PUSH BUTTON
17	6294044	PLATE, COVER	61	6294089	BOX, SWITCH
18	6294045	BOLT, SOC. HD. CAP, 5/16-18 X 2"	62	6294090	WASHER
19	6294046	HOLDER, IDLER PULLEY	63	6294091	CONTACTOR w/ THERMAL OVERLOAD RELAY (2 HP)
20	6294047	SCREW, SOC. HD. CAP, 1/4-20 X 5/8"	64	6294092	CONTACTOR w/ THERMAL OVERLOAD RELAY (1-1/2 HP)
21	6294048	TABLE, FRONT	65	6294093	TRANSFORMER 115/230V
22	6294049	PLATE, FRONT STEEL		6294122	TRANSFORMER 230/460V
23	6294050	ANGLE, TABLE	66	6294115	STOP, WORK
24	6294051	SCREW, HEX HD., 3/8-16 X 1"	67	6294116	SCREW, HEX HD 5/16-18 X 2-1/2"
25	6294052	SCREW, HEX HD., 3/8-16 X 5/8"	68	6294117	WASHER, 5/16"
26	6294053	HOLDER, HINGE	69	6294118	NUT, HEX 5/16"
27	6294054	BLOCK, SPRING ADJUSTING	70	6294119	WASHER, 1/2"
28	6294055	SPRING	71	6294120	LABEL, DIRECTION
29	6294056	SUPPORT, SWITCH	72	6294121	WASHER, SPRING, 5/16"
30	6294057	BOLT, KNOB	73	6294101	WIRE, MOTOR
31	6294058	RING, RETAINING	74	6294102	CORD, POWER
32	6294059	BEARING, #6205-LB	75	6294103	PROTECTOR, WIRE
33	6294060	GUARD, SAFETY	76	6294104	SCREW, SOC. HD. CAP, 1/4-24 X 3/8"
34	6294061	PULLEY	77	6294105	WIRE
35	6294062	BELT, ABRASIVE	78	6294106	SCREW, ROUND HD., 3/16-24 X 5/8"
36	6294063	SUPPORT, GUARD	79	6294107	LABEL, WARNING
37	6294064	SHAFT, PULLEY	80	6294108	CARD, I.D.
38	6294065	PLATEN, STEEL	81	6294109	LABEL, CAUTION
39	6294066	GRAPHITE	82	6294110	LABEL, LOGO
40	6294067	RING, RETAINING	83	6294111	STRIPE, COLOR
41	6294068	SHAFT, HINGE	84	6294112	WASHER, 3/8"
42	6294069	ANGLE, SUPPORT	85	6294113	SCREW, HEX HD., 3/8-16 X 3/4"
43	6294070	BASE	86	6294114	SCREW, HEX HD., 3/8-16 X 2-1/4"
44	6294071	KNOB, TABLE ADJUSTING			
45	6294072	SCREW, HEX HD., 1/4-20 X 3/8"			
46	6294073	WASHER, 1/4"			
47	6294074	SCREW, HEX HD., 5/16-18 X 5/8"			

# EXPLODED VIEW: Model 6108 Edge Sander

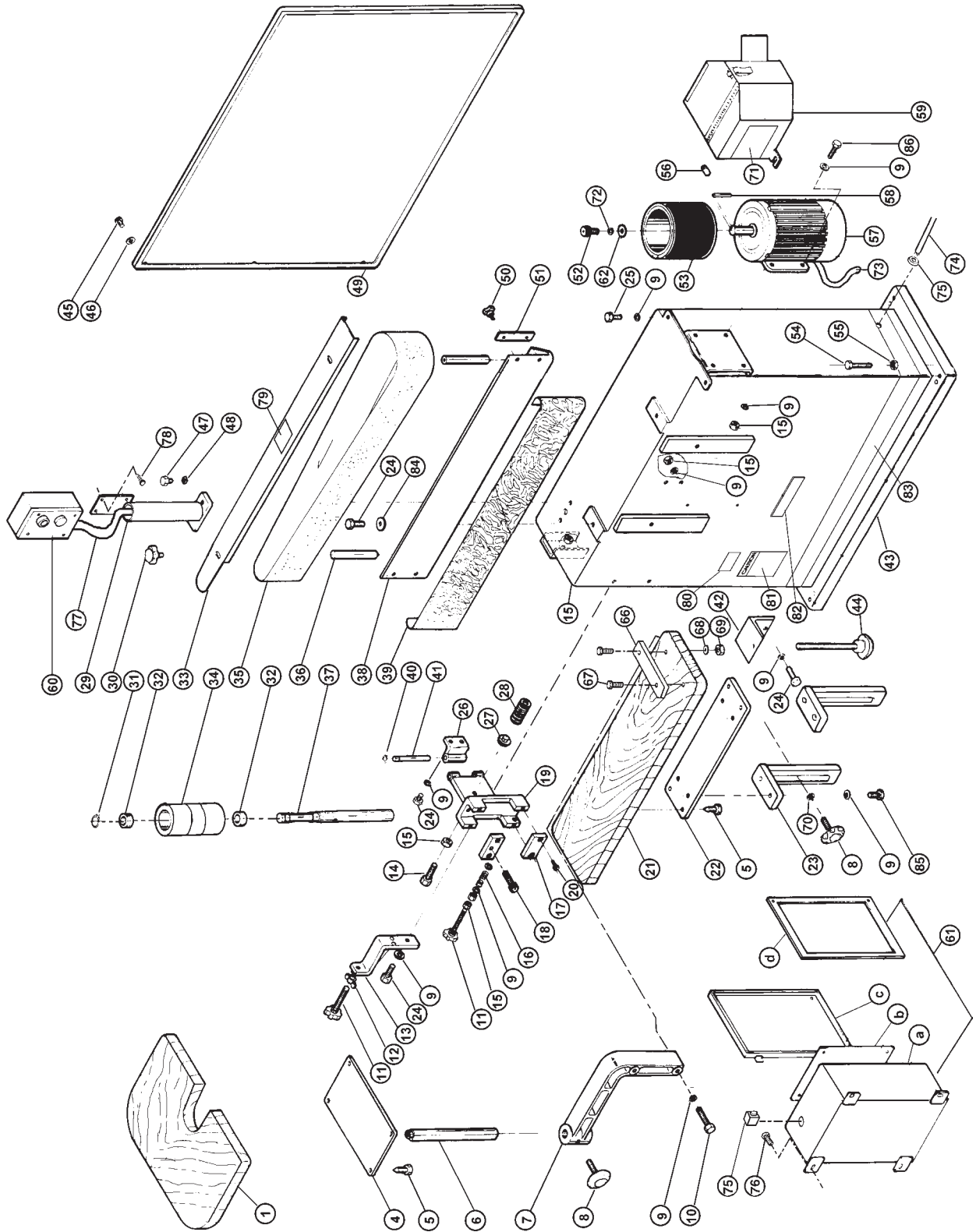

# ELECTRICAL SCHEMATIC (6108 Edge Sander)

115V/230V, 1 Phase

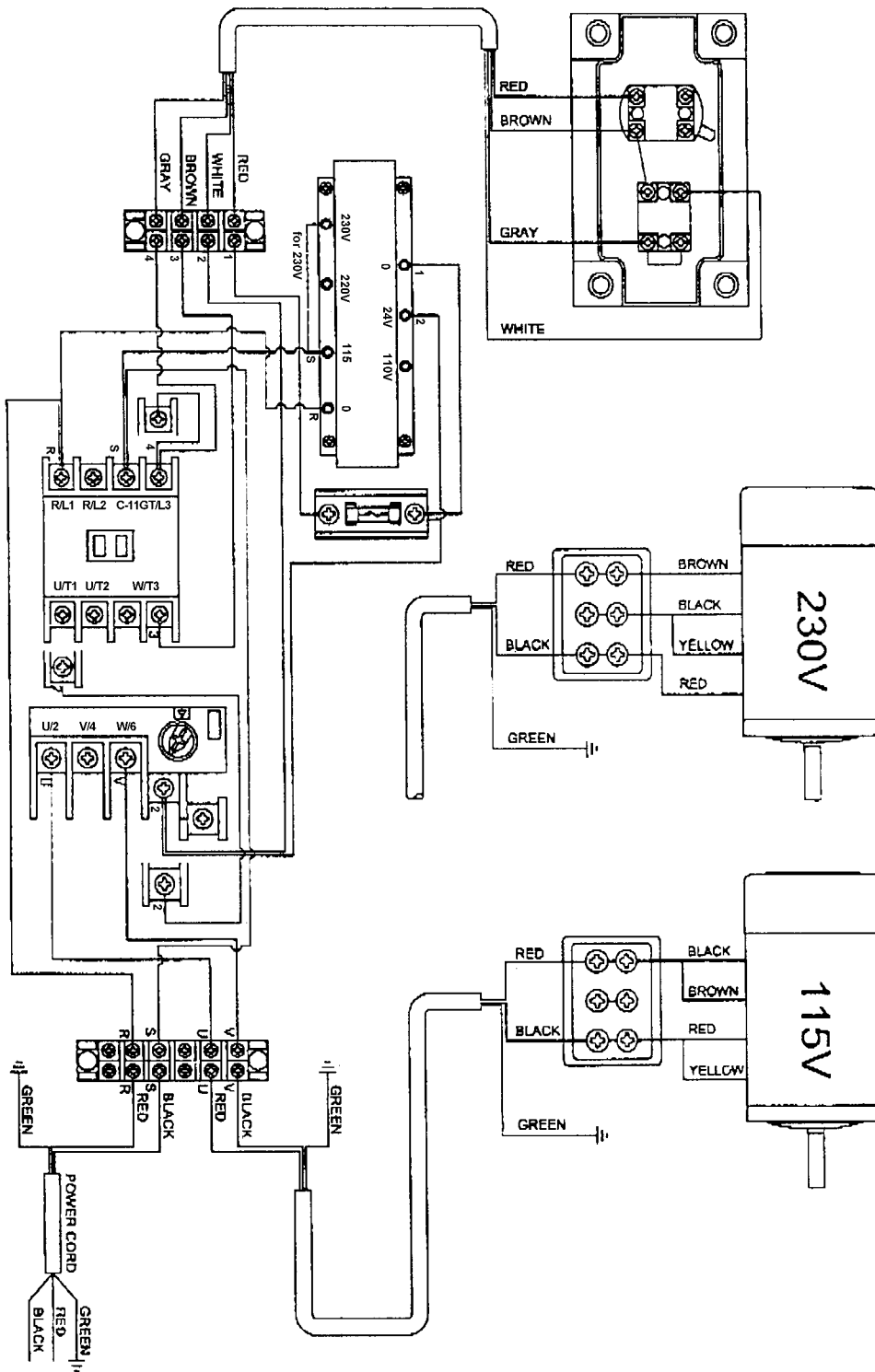

# ELECTRICAL SCHEMATIC (6108 Edge Sander)

230/460V, 3 Phase

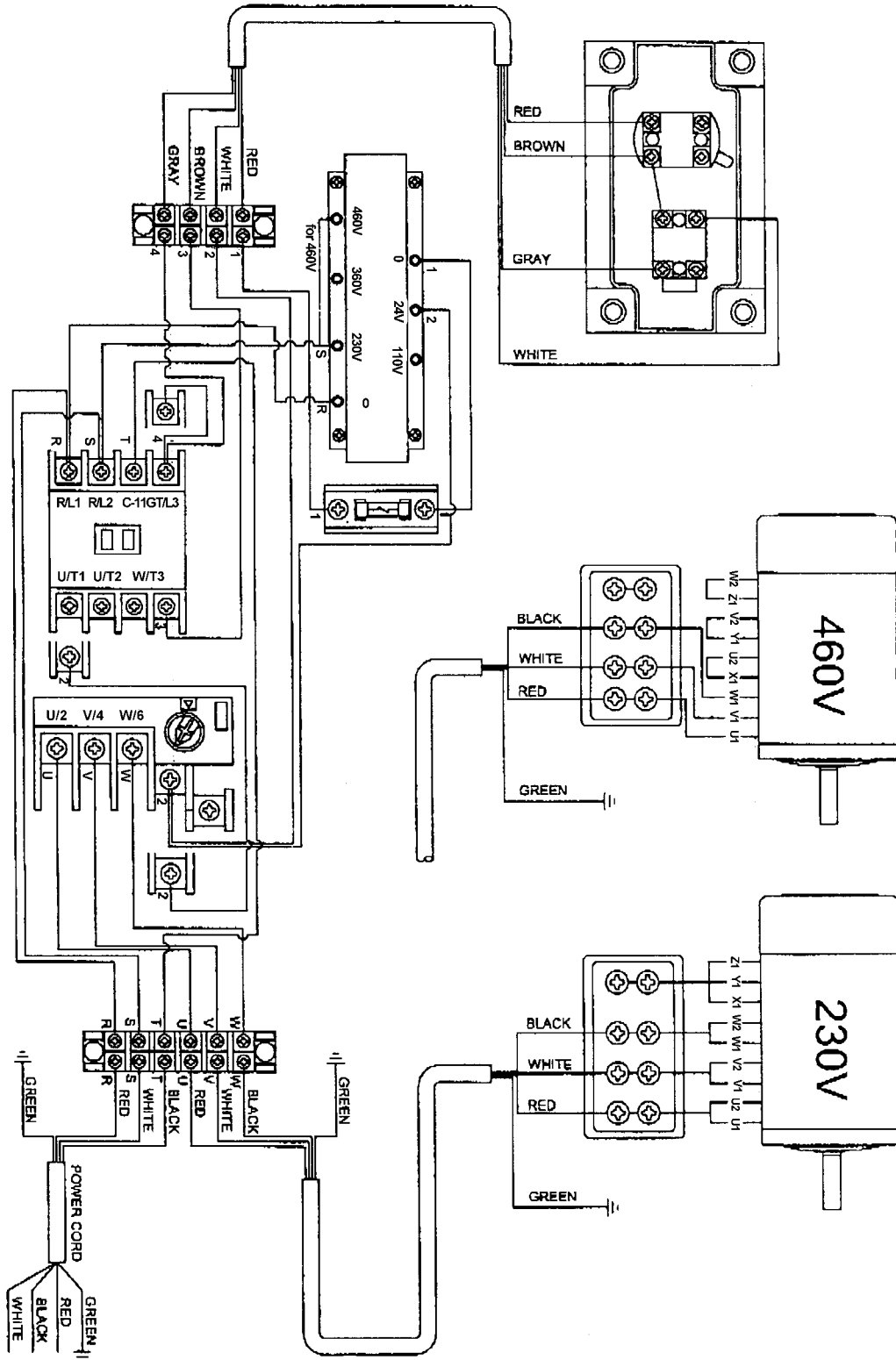

## OPTIONAL ACCESSORIES

6294094	Abrasive Belt, 6" x 108", 40 Grit.
6294095	Abrasive Belt, 6" x 108", 60 Grit.
6294096	Abrasive Belt, 6" x 108", 80 Grit.
6294062	Abrasive Belt, 6" x 108", 100 Grit.
6294098	Abrasive Belt, 6" x 108", 120 Grit.
6294099	Abrasive Belt, 6" x 108", 150 Grit.
6294100	Abrasive Belt, 6" x 108", 200 Grit.







To order parts or reach our service department, please call our toll free number between 8:00 A.M. and 4:30 P.M. (CST), Monday through Friday. Having the Model Number and Serial Number of your machine available when you call will allow us to serve you quickly and accurately. Locating the stock number of the part(s) required from your parts manual will also expedite your order.

Phone: (800) 274-6848

Fax: (800) 274-6840

If you are calling from Canada, please call 800-238-4746

E-mail: [powermatic@wmhtoolgroup.com](mailto:powermatic@wmhtoolgroup.com)

Website: [www.powermatic.com](http://www.powermatic.com)

# ***POWERMATIC***<sup>®</sup>

WMH Tool Group  
P.O. Box 1349  
Auburn, WA 98071-1349  
Phone: (800) 274-6848  
Fax: (800) 274-6840  
E-mail: [powermatic@wmhtoolgroup.com](mailto:powermatic@wmhtoolgroup.com)  
Website: [www.powermatic.com](http://www.powermatic.com)