



SERVICE PARTS LIST

BULLETIN NO.
54-38-1229

SPECIFY CATALOG NO. AND SERIAL NO. WHEN ORDERING PARTS			REVISED BULLETIN	DATE
5" ANGLE GRINDER			54-38-1228	Nov. 2005
CATALOG NO. 6149-02	STARTING SERIAL NUMBER	919E	WIRING INSTRUCTION	

EXAMPLE:

00 0 Component Parts (Small #)
Are Included When Ordering
The Assembly (Large #).

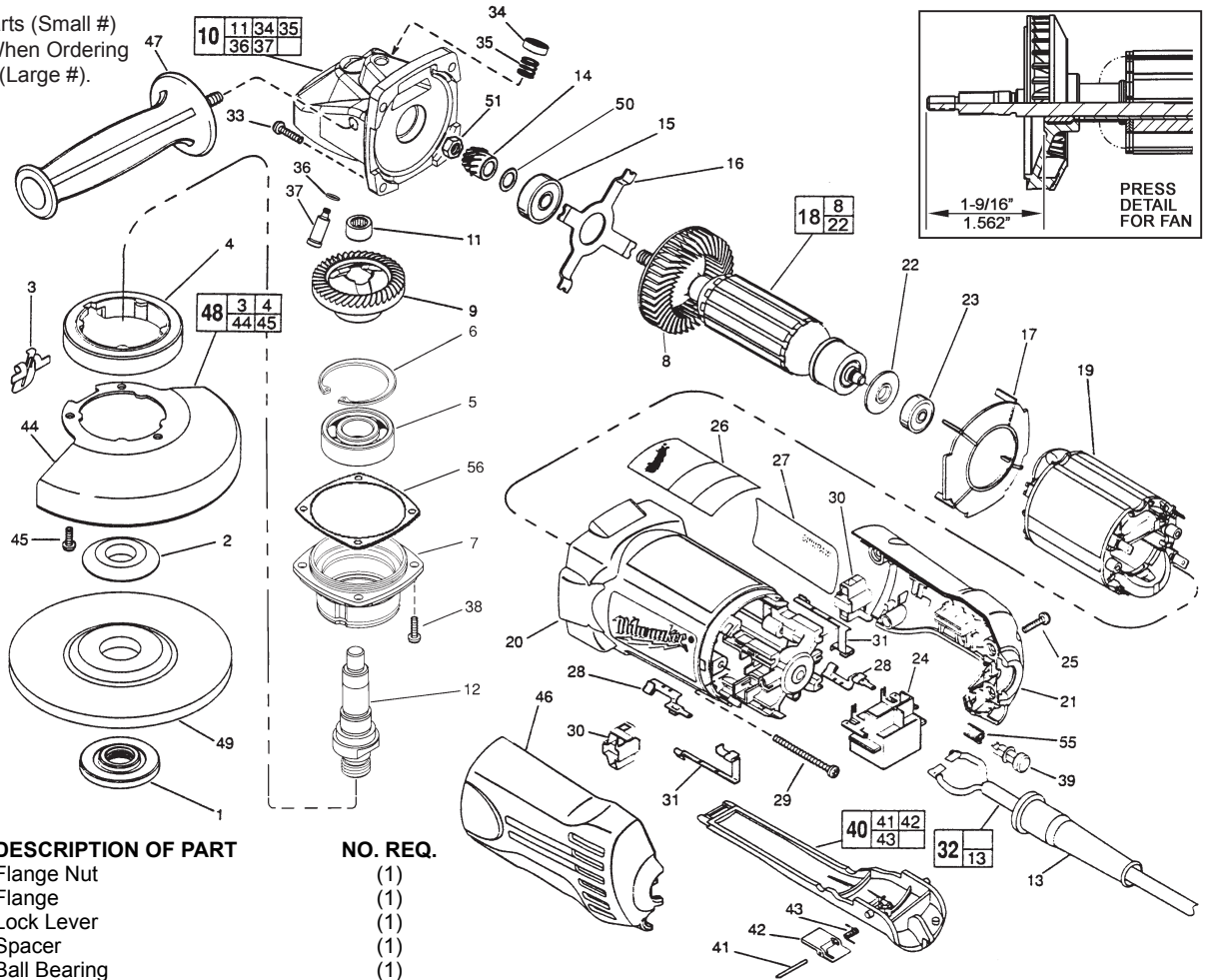

FIG.	PART NO.	DESCRIPTION OF PART	NO. REQ.
★ 1	49-05-0110	Flange Nut	(1)
★ 2	49-05-0125	Flange	(1)
3	44-20-0325	Lock Lever	(1)
4	45-36-1551	Spacer	(1)
5	02-04-1745	Ball Bearing	(1)
6	34-80-2960	Retaining Ring - Internal	(1)
7	28-52-0222	Spindle Hub	(1)
★ 8	22-84-0910	Fan Assembly	(1)
9	32-05-1310	P.M. Gear	(1)
★ 10	28-14-0705	Gear Case Assembly	(1)
11	02-50-2423	Needle Bearing	(1)
★ 12	38-50-5212	Spindle	(1)
13	44-76-0210	Cord Protector	(1)
14	32-60-1310	Pinion Gear	(1)
15	02-04-0852	Ball Bearing	(1)
16	44-66-5345	Bearing Retainer Plate	(1)
17	42-14-0400	Baffle	(1)
18	16-07-0201	Armature	(1)
19	18-07-0200	Field	(1)
★ 20	31-50-1125	Motor Housing	(1)
21	31-15-0450	Right Cover	(1)
22	23-16-0917	Commutator Insulator	(1)
23	02-04-2080	Ball Bearing	(1)
24	23-66-2401	Switch	(1)
25	06-82-7271	6-19 x 7/8" Pan Hd. Plastite T-15	(4)
26	12-20-6200	Service Nameplate Kit	(1)
27	10-98-7091	Warning Label	(1)
28	23-74-1206	Brush Terminal	(2)
29	06-82-7421	6-19 x 3-1/4" Pan Hd. Slit. Plast. T-15	(2)
★ 30	22-20-1010	Brush Holder Assy. (Incl. Carbon Brush)	(2)
31	23-74-1201	Switch Terminal	(2)
32	22-64-0840	Cord Set Assembly	(1)
33	06-82-7326	8-16 x 1" Pan Hd. Slit. Plast. T-20	(4)
34	31-12-0205	Cap	(1)
35	40-50-8650	Compression Spring	(1)
36	34-40-4300	O-Ring	(1)
37	44-60-0845	Lock Pin	(1)
38	06-82-5316	8-32 x 1/2" Pan Hd. Slit. Tapt. T-20	(4)

FIG.	PART NO.	DESCRIPTION OF PART	NO. REQ.
39	42-42-0395	Lock-On Button	(1)
40	31-92-0320	Paddle Assembly	(1)
41	06-65-1915	Pin	(1)
42	42-42-0390	Lock-Off Button	(1)
43	40-50-8750	Torsion Spring	(1)
44	28-41-1025	Hood	(1)
45	06-82-7251	8-16 x 3/8" Pan Hd. Slit. Plast. T-20	(3)
46	31-15-0455	Left Cover	(1)
47	49-15-0310	Side Handle	(1)
48	49-12-0366	Guard Assembly	(1)
49	-----	5" Disc - Select From Catalog	(1)
50	45-14-0280	Pinion Shim	(1)
51	06-55-3850	10-32 Hex Nut	(1)
55	40-50-0921	Compression Spring	(1)
★ 56	43-44-1080	Gasket	(1)
	49-96-7205	Spanner Wrench	(1)

FIG. LUBRICATION:
9, 14 Type "Y" Grease, No. 49-08-5270, Must Be Applied To All Gear Teeth.
10 9-12 Grams Type "Y" Grease, No. 49-08-5270.

FIG. NOTES:
7 Position The Spindle Hub With The Side That Has The Word "Back" Orientated Toward The Rear Of The Tool. Press .09" Below Casting Surface.
32 Tuck All Cord Leads Away From Vent Openings.
51 Torque To 25-35 In./Lbs.