



SERVICE PARTS LIST

BULLETIN NO.
54-40-0240

SPECIFY CATALOG NO. AND SERIAL NO. WHEN ORDERING PARTS		REVISED BULLETIN	DATE
12" CHOP SAW			Sept. '90
CATALOG NO. 6165	STARTING SERIAL NO. 582-1001	WIRING INSTRUCTION SEE REVERSE SIDE	

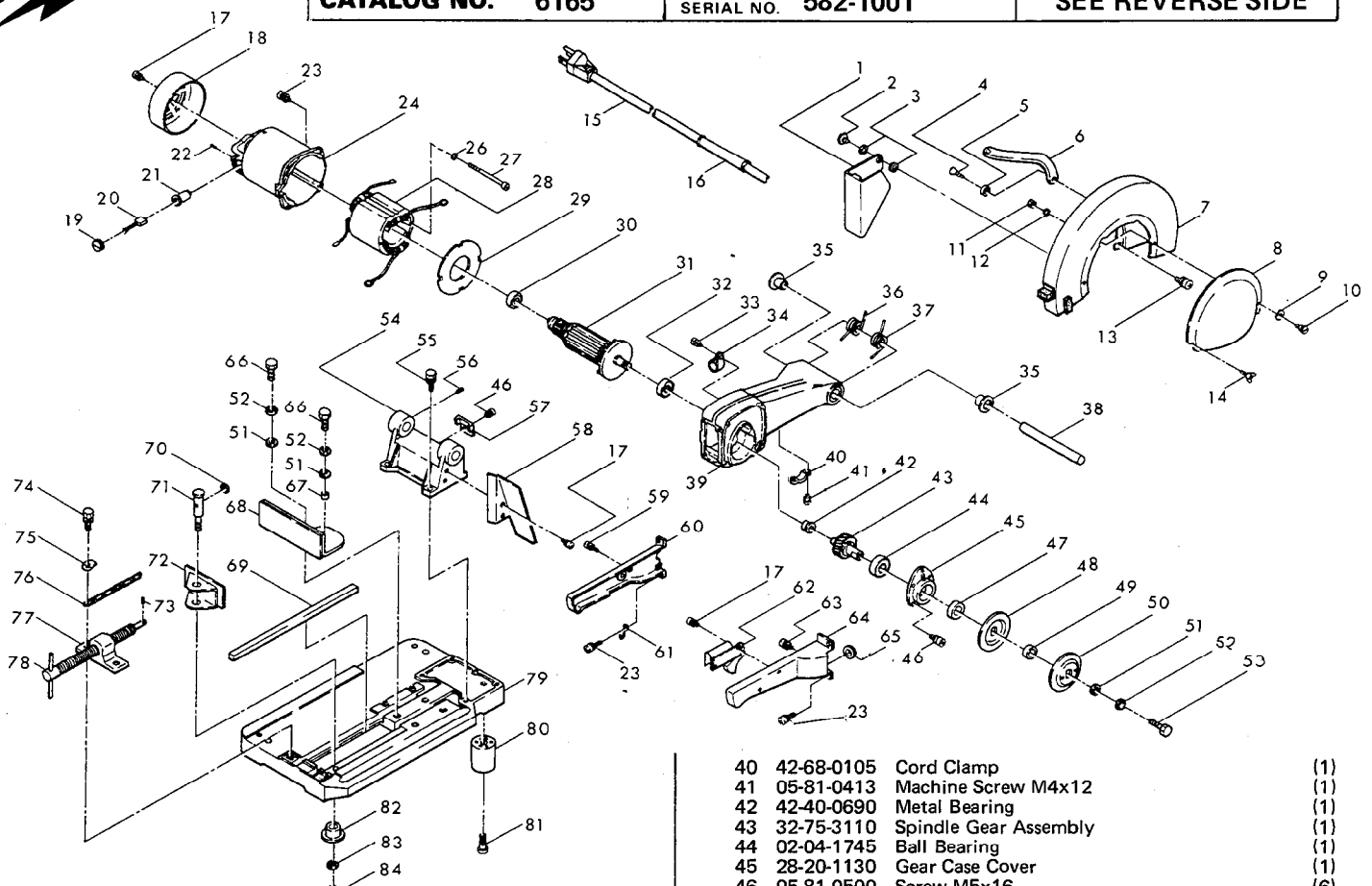

FIG.	PART NO.	DESCRIPTION OF PART	NO. REQ.
	1	43-54-0470 Front Guard	(1)
	2	05-77-0250 Guard Bolt	(1)
	3	45-88-7890 Nylon Washer	(2)
	4	05-81-0700 Machine Screw M6x16	(2)
	5	45-88-7895 Washer	(2)
	6	45-56-0180 Carrying Handle	(1)
	7	43-54-0475 Wheel Guard	(1)
	8	42-92-0500 Wheel Guard Cover	(1)
	9	45-88-0585 Wave Washer	(1)
	10	05-77-1050 Bolt M4	(1)
	11	05-55-0003 Nut M4 (Includes Fig. No. 12)	(1)
	12	Spring Washer	(1)
	13	05-81-0710 Screw M6x16	(4)
	14	05-77-0550 Wing Screw M5x10	(1)
	15	22-64-4465 Cord Set	(1)
	16	44-76-0140 Cord Protector	(1)
	17	05-78-0450 Machine Screw M4x8	(6)
	18	42-92-0510 Motor End Cover	(1)
	19	22-24-0270 Brush Holder Cap	(2)
	20	22-16-0310 Carbon Brush	(2)
	21	22-20-0460 Brush Holder	(2)
	22	05-81-0480 Screw M5x10	(2)
	23	05-81-0750 Machine Screw M6x20	(8)
	24	31-50-0440 Motor Housing	(1)
	26	45-88-0708 Spring Washer	(2)
	27	05-81-0675 Field Screw M5x88	(2)
	28	18-82-1240 Field	(1)
	29	42-14-0280 Air Baffle	(1)
	30	02-04-1050 Ball Bearing	(1)
	31	16-82-1850 Armature Assembly	(1)
	32	02-04-1535 Ball Bearing	(1)
	33	05-81-0475 Machine Screw	(1)
	34	43-72-0110 Cord Holder	(1)
	35	42-40-0680 Nylon Bushing	(2)
	36	40-50-0965 Left Torsion Spring	(1)
	37	40-50-0975 Right Torsion Spring	(1)
	38	06-65-1800 Hinge Pin	(1)
	39	31-40-0045 Gear Case	(1)

40	42-68-0105	Cord Clamp	(1)
41	05-81-0413	Machine Screw M4x12	(1)
42	42-40-0690	Metal Bearing	(1)
43	32-75-3110	Spindle Gear Assembly	(1)
44	02-04-1745	Ball Bearing	(1)
45	28-20-1130	Gear Case Cover	(1)
46	05-81-0500	Screw M5x16	(6)
47	42-76-0320	Spindle Collar	(1)
48	43-34-0515	Inside Flange	(1)
49	42-76-0340	Wheel Collar	(1)
50	43-34-0525	Outside Flange	(3)
51	45-88-5375	Flat Washer	(3)
52	05-90-0175	Lock Washer	(3)
53	05-77-2500	Bolt M10x1.25 x 22	(1)
54	42-36-1470	Hinge Bracket	(1)
55	05-77-1600	Bolt M6x20	(5)
56	05-86-0590	Allen Hd. Set Screw M6x8	(1)
57	45-52-2020	Stop	(1)
58	45-12-0350	Spark Shield	(1)
59	05-81-0420	Screw M4x20	(4)
60	31-44-1280	Left Handle Half	(1)
61	43-74-0100	Hook	(1)
62	23-66-1320	Switch	(1)
63	05-81-0400	Screw M4x6	(1)
64	31-44-1275	Right Handle Half	(1)
65	42-40-0685	Bushing	(1)
66	05-77-2520	Bolt M10 x 1.25 x 25	(2)
67	42-76-0330	Vise Pivot Collar	(1)
68	42-68-0475	Fixed Vise	(1)
69	30-37-0030	Vise Guide	(2)
70	45-88-0715	Washer	(1)
71	06-65-1900	Vise Pin	(1)
72	42-68-0485	Moveable Vise	(1)
73	06-65-1680	Roll Pin	(1)
74	05-77-1800	Bolt M8x25	(2)
75	43-72-0120	Chain Holder	(1)
76	42-60-0150	Link Chain	(1)
77	44-40-0580	Vise Screw Nut	(1)
78	45-04-0640	Vise Screw	(1)
79	31-06-0080	Base	(1)
80	44-34-0140	Rubber Mount	(4)
81	05-81-0900	Machine Screw M8x30	(4)
82	42-76-0350	Collar	(1)
83	05-90-0200	Lock Washer	(1)
84	05-55-1500	Nut M12	(1)

MILWAUKEE ELECTRIC TOOL CORPORATION
13135 W. LISBON RD., BROOKFIELD, WIS. 53005

CIRCUIT DIAGRAM

