



SERVICE PARTS LIST

BULLETIN NO.
54-40-0641

SPECIFY CATALOG NO. AND SERIAL NO. WHEN ORDERING PARTS			REVISED BULLETIN 54-40-0640	DATE Jan. 2009
14" ABRASIVE CUT-OFF MACHINE				
CATALOG NO.	6185-20	SERIAL NUMBER	A20C	
			WIRING INSTRUCTION 58-01-1373	

- FIG. 21 LUBRICATION:**
1.25 oz. (35 grams) of Type "Y" grease, No. 49-08-5270 in main gear cavity of gearcase.
- 29,30 "Y" grease must be applied to all gear teeth.
- 31,32 Lightly coat o-rings with "Y" grease prior to installation.

Fig. nos. 49, 48 and 2 are to be assembled into gearcase bearing pocket and held in place with fig. nos. 46 and 50, as shown. Slide armature shaft through bearing, dust shield (#66), and fig. no. 30 (inside gearcase) and fasten to specified torque with left hand hex nut, fig. no. 5.

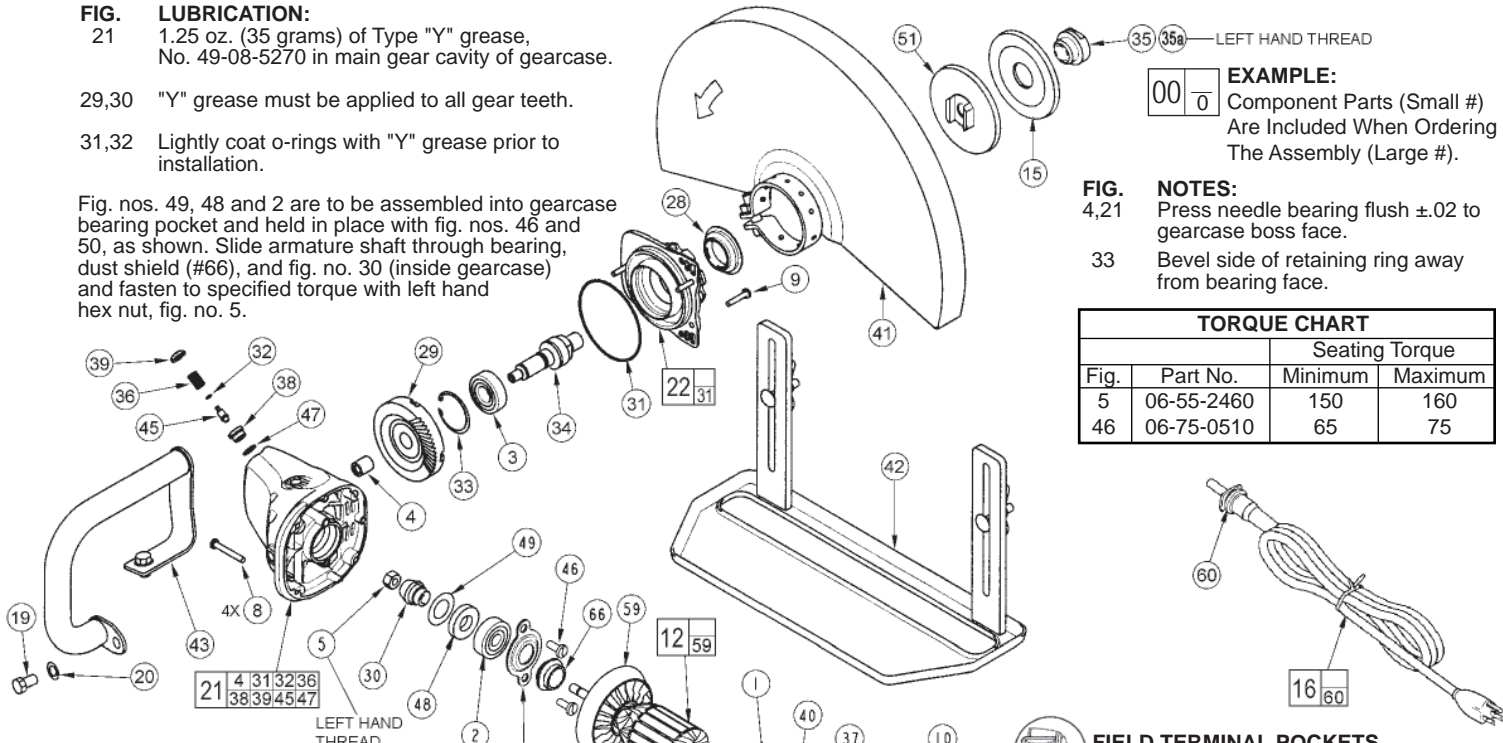

EXAMPLE:
Component Parts (Small #) Are Included When Ordering The Assembly (Large #).

- FIG. 4,21 NOTES:**
Press needle bearing flush ±.02 to gearcase boss face.
- 33 Bevel side of retaining ring away from bearing face.

TORQUE CHART			
		Seating Torque	
Fig.	Part No.	Minimum	Maximum
5	06-55-2460	150	160
46	06-75-0510	65	75

FIG.	PART NO.	DESCRIPTION OF PART	NO REQ.
1	02-04-1675	Ball Bearing	(1)
2	02-04-1680	Ball Bearing	(1)
3	02-04-1745	Ball Bearing	(1)
4	02-50-2429	Needle Bearing	(1)
5	06-55-2460	Hex Nut - Left Hand Thread	(1)
★ 6	14-34-0566	Handle Kit	(1)
7	06-82-0055	8-16 Torx Plastite Screw T-20	(5)
8	06-82-0060	10-14 Torx Plastite Screw T-25	(4)
9	06-82-0065	10-32 x 1 Pan Hd. Taptite T-25 Screw	(2)
★ 10	06-82-7435	8-16 x 3-3/64" Pan Hd. Plastite Screw T-20	(3)
11	06-82-7240	6-19 x 1/2 Slt. Pan Hd. Plast. T-15	(3)
★ 12	16-70-7135	Armature Assembly	(1)
★ 13	18-70-7135	Field	(1)
14	22-20-0120	Brush Holder Assembly	(2)
15	43-34-0845	Outer Flange	(1)
★ 16	22-64-1206	Cord Set (Incl. Cord Protector & Terminals)	(1)
17	23-44-0255	Brush Cover	(2)
★ 18	23-66-2726	Switch	(1)
19	06-75-0494	3/8-16 Hex Hd. Bolt	(2)
20	06-97-0070	3/8 Split Ring Lock Washer	(2)
21	28-14-1136	Gearcase Kit	(1)
22	28-53-0301	Spindle Hub Kit	(1)
23	31-15-0166	Cover	(1)
24	-----	Left Hand Handle Halve	(1)
25	-----	Right Hand Handle Halve	(1)
26	31-50-1785	Motor Housing	(1)
★ 27	31-53-0161	Plug	(1)
28	31-55-0150	Bearing Shield	(1)
29	32-05-1530	Gear	(1)
30	32-60-1530	Pinion Gear	(1)
31	34-40-0505	O-Ring	(1)
32	-----	O-Ring	(1)
33	34-80-2960	Retaining Ring	(1)
34	38-50-1520	Spindle Shaft (See Note)	(1)
35	44-40-0815	1.0" Flange Nut - Left Hand Thread	(1)
35a	44-40-0820	20mm L.H. Flange Nut	(1)
36	-----	Compression Spring	(1)
37	42-14-0425	Baffle	(1)
38	-----	Lock Body	(1)
39	-----	Button	(1)
40	45-06-1000	Dust Seal	(1)
41	43-54-1510	Guard Assembly	(1)
42	43-40-0415	Shoe Assembly	(1)
43	43-62-1510	Handle Assembly	(1)
45	-----	Lock Pin	(1)
46	06-75-0510	1/4-20 x .625 Hex Flange Screw	(2)
47	-----	O-Ring	(1)
48	45-06-0710	Seal	(1)
49	45-88-7880	Shim Washer	(1)
50	44-86-0040	Bearing Retainer	(1)

FIG.	PART NO.	DESCRIPTION OF PART	NO REQ.
51	43-34-0850	Inner Flange	(1)
54	22-56-0480	Terminal Block	(1)
59	22-84-0540	Fan Assembly	(1)
★ 60	-----	Cord Protector	(1)
61	22-18-0126	Carbon Brush Assembly	(2)
62	-----	Brush Spring	(2)
★ 63	12-99-5010	Nameplate Blank	(1)
64	05-78-0305	Switch Screw	(4)
65	45-06-0830	Bearing Seal	(1)
66	31-55-0290	Dust Shield	(1)
67	22-36-0350	Breaker	(1)
★ 68	23-82-0360	Heat Shrink Tube	(4)
-----	49-96-0380	Hex Wrench (Not Shown)	(1)
-----	23-94-9300	Leadwire Assembly - Red (Not Shown)	(1)
-----	23-94-9305	Leadwire Assembly - White (Not Shown)	(1)
★	23-94-9314	Leadwire Assembly - White (Not Shown)	(1)
★	23-94-5091	Leadwire Assembly - Black (Not Shown)	(1)
★	23-94-5096	Leadwire Assembly - Black (Not Shown)	(1)
★	23-94-5650	Ground Wire Assembly - Green (Not Shown)	(1)
★	10-98-6085	Warning Label - French and Spanish	(1)

MILWAUKEE ELECTRIC TOOL CORPORATION
13135 W. LISBON RD., BROOKFIELD, WI 53005