

J E T[®]

Operating Instructions and Parts Manual Drum Sander Model 16-32 Plus



shown with optional casters (98-0130) and infeed/outfeed tables (98-1601)

WALTER MEIER (Manufacturing) Inc.

427 New Sanford Road
LaVergne, Tennessee 37086
Ph.: 800-274-6848
www.waltermeier.com

Part No. M-629004

Revision B3 06/2011

Copyright © 2011 Walter Meier (Manufacturing) Inc.

WARRANTY AND SERVICE

Walter Meier (Manufacturing) Inc., warrants every product it sells. If one of our tools needs service or repair, one of our Authorized Service Centers located throughout the United States can give you quick service. In most cases, any of these Walter Meier Authorized Service Centers can authorize warranty repair, assist you in obtaining parts, or perform routine maintenance and major repair on your JET® tools. For the name of an Authorized Service Center in your area call 1-800-274-6848.

MORE INFORMATION

Walter Meier is consistently adding new products to the line. For complete, up-to-date product information, check with your local Walter Meier distributor, or visit waltermeier.com.

WARRANTY

JET® products carry a limited warranty which varies in duration based upon the product (MW stands for Metalworking, WW stands for Woodworking).

90 DAY WARRANTY	1 YEAR WARRANTY	Body Repair Kits Bottle Jacks Cable Pullers Cold Saws Hoists-Air Hoists-Electric Metal forming Mill/Drills Milling Machines MW Bandsaws MW Drill Presses MW Finishing Equipment MW Lathes MW Precision Vises	2 YEAR WARRANTY	Palet Trucks Rigging Equip. Service Jacks Stackers Surface Grinders Tapping Trolleys-Air Trolleys-Electric Web Slings Winches-Electric	3 YEAR WARRANTY	WW Benchtop Tools	5 YEAR WARRANTY	Beam Clamps Chain Hoist- Manual Lever Hoists Pullers-JCH Models Scissor Lift Tables Screw Jacks Trolleys-Gearred Trolleys-Plain Winches-Manual WW Air Filtration WW Bandsaws WW Buffers	5 YEAR WARRANTY	WW Drill Presses WW Dust Collectors WW Dust Filters WW Dust Fittings WW Jointers WW Lathes WW Planers WW Sanders WW Shapers WW Tablesaws	LIFE LIFETIME WARRANTY	Fastening Tools Mechanics Hand Tools Striking Tools Vises (no -precision) Clamps
<i>Warranty reverts to 1 Year Warranty if woodworking (WW) products listed above are used for industrial or educational purposes.</i>												

WHAT IS COVERED?

This warranty covers any defects in workmanship or materials subject to the exceptions stated below. Cutting tools, abrasives and other consumables are excluded from warranty coverage.

WHO IS COVERED?

This warranty covers only the initial purchaser of the product.

WHAT IS THE PERIOD OF COVERAGE?

The general JET warranty lasts for the time period specified in the product literature of each product.

WHAT IS NOT COVERED?

Five Year and Lifetime Warranties do not cover products used for commercial, industrial or educational purposes. Products with Five Year or Lifetime Warranties that are used for commercial, industrial or education purposes revert to a One Year Warranty. This warranty does not cover defects due directly or indirectly to misuse, abuse, negligence or accidents, normal wear-and-tear, improper repair or alterations, or lack of maintenance.

HOW TO GET SERVICE

The product or part must be returned for examination, postage prepaid, to a location designated by us. For the name of the location nearest you, please call 1-800-274-6848.

You must provide proof of initial purchase date and an explanation of the complaint must accompany the merchandise. If our inspection discloses a defect, we will repair or replace the product, or refund the purchase price, at our option. We will return the repaired product or replacement at our expense unless it is determined by us that there is no defect, or that the defect resulted from causes not within the scope of our warranty in which case we will, at your direction, dispose of or return the product. In the event you choose to have the product returned, you will be responsible for the shipping and handling costs of the return.

HOW STATE LAW APPLIES

This warranty gives you specific legal rights; you may also have other rights which vary from state to state.

LIMITATIONS ON THIS WARRANTY

WALTER MEIER (MANUFACTURING) INC., LIMITS ALL IMPLIED WARRANTIES TO THE PERIOD OF THE LIMITED WARRANTY FOR EACH PRODUCT. EXCEPT AS STATED HEREIN, ANY IMPLIED WARRANTIES OR MERCHANTABILITY AND FITNESS ARE EXCLUDED. SOME STATES DO NOT ALLOW LIMITATIONS ON HOW LONG THE IMPLIED WARRANTY LASTS, SO THE ABOVE LIMITATION MAY NOT APPLY TO YOU.

WALTER MEIER SHALL IN NO EVENT BE LIABLE FOR DEATH, INJURIES TO PERSONS OR PROPERTY, OR FOR INCIDENTAL, CONTINGENT, SPECIAL, OR CONSEQUENTIAL DAMAGES ARISING FROM THE USE OF OUR PRODUCTS. SOME STATES DO NOT ALLOW THE EXCLUSION OR LIMITATION OF INCIDENTAL OR CONSEQUENTIAL DAMAGES, SO THE ABOVE LIMITATION OR EXCLUSION MAY NOT APPLY TO YOU.

Walter Meier sells through distributors only. The specifications in Walter Meier catalogs are given as general information and are not binding. Members of Walter Meier reserve the right to effect at any time, without prior notice, those alterations to parts, fittings, and accessory equipment which they may deem necessary for any reason whatsoever. JET® branded products are not sold in Canada by Walter Meier.

Table of Contents

Table of Contents	3
Warning	4
Introduction	6
Specifications	6
Features and Terminology	7
Unpacking.....	8
Contents of Boxes	8
Assembling the Stand	9
Casters (<i>Optional Accessory</i>).....	9
Assembling the Sander	10
Installing Drum Head	10
Installing Conveyor	10
Infeed and Outfeed Tables (<i>Optional Accessory</i>).....	11
Dust Collection	12
Installing Abrasives.....	12
Grounding Instructions.....	14
Extension Cords.....	15
Adjustments	15
Drum Height Control.....	15
Switch Lock	15
Depth Gauge	15
Dust Cover Latch	16
Conveyor Belt Tension/Tracking.....	16
Conveyor Belt Replacement.....	16
Sanding Drum Alignment	17
Drum Height Control Adjustment	18
Tension Roller Alignment	19
Tension Roller Pressure Adjustment	19
Operation.....	20
Basic Operating Procedure	20
Setting Depth of Cut	20
Establishing Proper Drum Height.....	20
Selecting SandSmart™ Feed Rates	20
Tips for Maximum Performance.....	21
Multiple-Piece Sanding Runs	21
Maintenance	22
Tracker Kit (98-0080).....	23
Abrasives.....	26
Optional Accessories	27
Replacement Parts	27
Conveyor and Motor Assembly.....	28
Parts List: Conveyor and Motor Assembly	29
Drum Head Assembly.....	30
Parts List: Drum Head Assembly	31
Parts List: Infeed/Outfeed Tables (<i>Optional Accessory</i>).....	32
Parts List: Stand Assembly	33
Electrical Connections.....	34

Warnings

1. Read and understand this entire manual before attempting assembly or operation.
2. Read and understand the warnings posted on the machine and in this manual. Failure to comply with all of these warnings may cause serious injury.
3. Replace the warning labels if they become obscured or removed.
4. This sander is designed and intended for use by properly trained and experienced personnel only. If you are not familiar with the proper and safe operation of a sander, do not use until proper training and knowledge have been obtained.
5. Do not use this sander for other than its intended use. If used for other purposes, Walter Meier (Manufacturing) Inc., disclaims any real or implied warranty and holds itself harmless from any injury that may result from that use.
6. Always wear approved safety glasses/face shields while using this sander. Everyday eyeglasses only have impact resistant lenses; they are not safety glasses.
7. Before operating this sander, remove tie, rings, watches and other jewelry, and roll sleeves up past the elbows. Remove all loose clothing and confine long hair. Non-slip footwear or anti-skid floor strips are recommended. Do **not** wear gloves.
8. Wear ear protectors (plugs or muffs) during extended periods of operation.
9. Some dust created by power sanding, sawing, grinding, drilling and other construction activities contain chemicals known to cause cancer, birth defects or other reproductive harm. Some examples of these chemicals are:
 - Lead from lead based paint.
 - Crystalline silica from bricks, cement and other masonry products.
 - Arsenic and chromium from chemically treated lumber.Your risk of exposure varies, depending on how often you do this type of work. To reduce your exposure to these chemicals, work in a well-ventilated area and work with approved safety equipment, such as face or dust masks that are specifically designed to filter out microscopic particles.
10. Do not operate this machine while tired or under the influence of drugs, alcohol or any medication.
11. Make certain the switch is in the **OFF** position before connecting the machine to the power supply.
12. Make certain the machine is properly grounded.
13. Make all machine adjustments or maintenance with the machine unplugged from the power source.
14. Remove adjusting keys and wrenches. Form a habit of checking to see that keys and adjusting wrenches are removed from the machine before turning it on.
15. Keep safety guards in place at all times when the machine is in use. If removed for maintenance purposes, use extreme caution and replace the guards immediately.
16. Make sure the sander is firmly secured to the stand or work table before use.
17. Check damaged parts. Before further use of the machine, a guard or other part that is damaged should be carefully checked to determine that it will operate properly and perform its intended function. Check for alignment of moving parts, binding of moving parts, breakage of parts, mounting and any other conditions that may affect its operation. A guard or other part that is damaged should be properly repaired or replaced.
18. Provide for adequate space surrounding work area and non-glare, overhead lighting.
19. Keep the floor around the machine clean and free of scrap material, oil and grease.
20. Keep visitors a safe distance from the work area. **Keep children away.**

Warnings

21. Make your workshop child proof with padlocks, master switches or by removing starter keys.
22. Give your work undivided attention. Looking around, carrying on a conversation and “horse-play” are careless acts that can result in serious injury.
23. Maintain a balanced stance at all times so that you do not fall or lean against moving parts. Do not over-reach or use excessive force to perform any machine operation.
24. Stand to one side of the conveyor and make sure no one else is standing in line with the conveyor while feeding stock into the machine. Should a part slip while being fed, it may exit the machine at a high rate of speed and can cause injuries to anyone standing directly in front of the infeed.
25. Use the right tool at the correct speed and feed rate. Do not force a tool or attachment to do a job for which it was not designed. The right tool will do the job better and safer.
26. Use recommended accessories; improper accessories may be hazardous.
27. Maintain tools with care. Keep abrasives clean for the best and safest performance. Follow instructions for lubricating the machine and changing accessories.
28. Always feed stock against the rotation of the drum.
29. Keep your hands clear when feeding parts onto the conveyor. The part will be forced down as it begins to feed, causing a pinching action between the part and the conveyor bed. Never reach into a running machine. Turn off sander and disconnect from power before attempting to retrieve parts from within the machine.
30. Turn off the machine and disconnect from power before cleaning. Use a brush or compressed air to remove chips or debris — do not use your hands.
31. Do not stand on the machine. Serious injury could occur if the machine tips over.
32. Never leave the machine running unattended. Turn the power off and do not leave the machine until it comes to a complete stop.
33. Remove loose items and unnecessary work pieces from the area before starting the machine.

Familiarize yourself with the following safety notices used in this manual:

CAUTION This means that if precautions are not heeded, it may result in minor injury and/or possible machine damage.

WARNING This means that if precautions are not heeded, it may result in serious injury or possibly even death.

- - SAVE THESE INSTRUCTIONS - -

Introduction

This manual is provided by Walter Meier (Manufacturing) Inc., covering the safe operation and maintenance procedures for a JET Model 16-32 Plus Drum Sander. This manual contains instructions on installation, safety precautions, general operating procedures, maintenance instructions and parts breakdown. This machine has been designed and constructed to provide years of trouble free operation if used in accordance with instructions set forth in this manual. If there are any questions or comments, please contact either your local supplier or Walter Meier. Walter Meier can also be reached at our web site: www.waltermeier.com.

Specifications

Stock Number	629004K
Model Number	16-32 Plus
Maximum Sanding Width (in.)	32 (two passes)
Minimum Sanding Length (in.)	2-1/4
Maximum Thickness (in.)	3
Minimum Thickness (in.)	1/32
Overall Dimensions (HxWxD)(in.)	48 x 35 x 24-3/4
Drum Dimensions (dia.x L)(in.)	5 x 16
Drum Speed (RPM)	1720
Drum Bearing Diameter (in.)	1
Dust Port Diameter (in.)	4
Conveyor Motor	43-in.-lbs. torque, direct drive, DC
Conveyor Variable Feed Rate (SFPM)	0 to 10 (SandSmart™)
Drum Motor	TEFC Induction, 1.5HP (1.1kW), 1PH, 110V, 14A, 60Hz
Net Weight (lbs.)	164

The above specifications were current at the time this manual was published, but because of our policy of continuous improvement, Walter Meier (Manufacturing) Inc., reserves the right to change specifications at any time and without prior notice, without incurring obligations.

Features and Terminology

The illustration below shows the major components and features of the 16-32 Plus Sander. These are referenced throughout the manual and will help to familiarize you with the operation and functions of the machine.

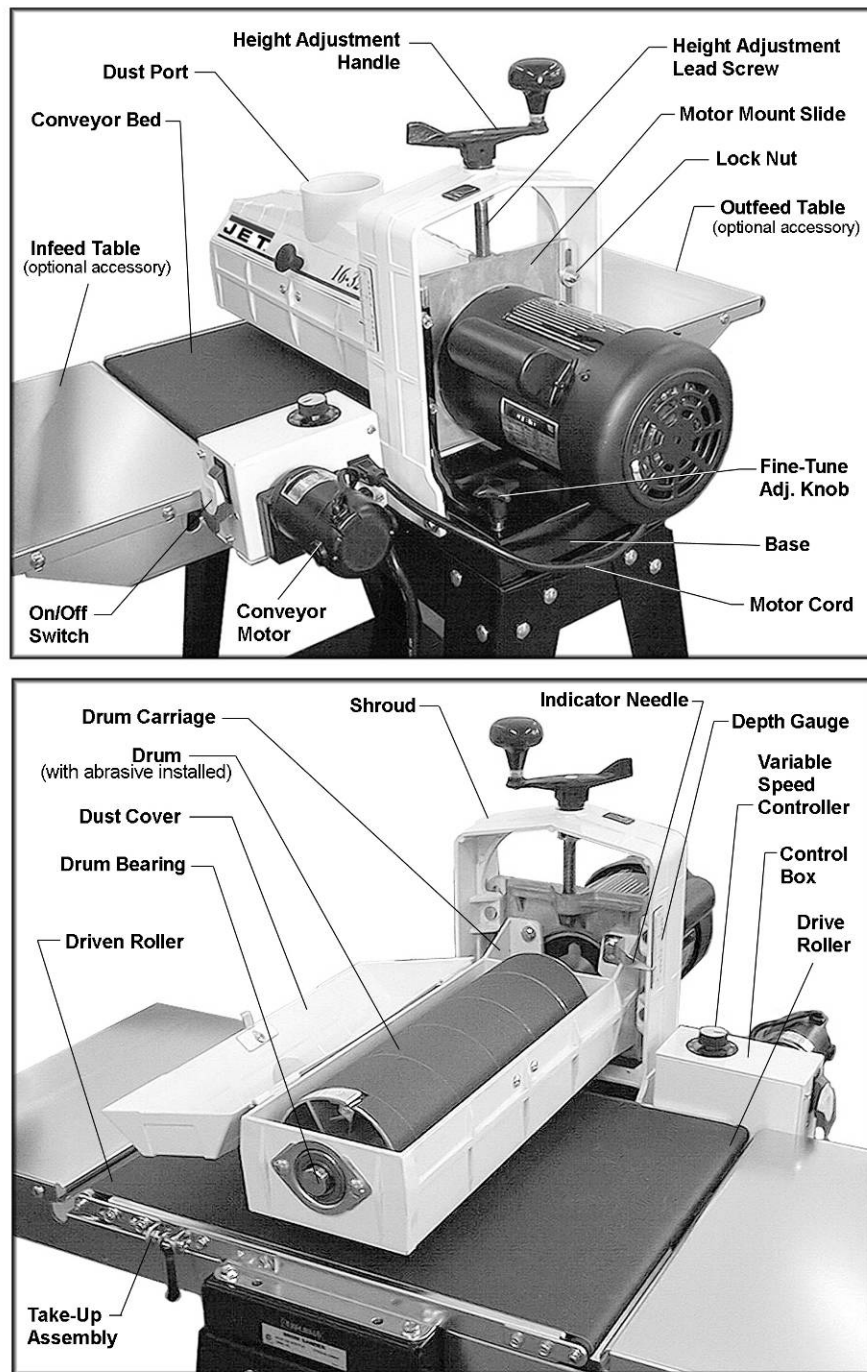

Figure 1

Unpacking

Open boxes and check for shipping damage. Report any damage immediately to your distributor and shipping agent. Do not discard any shipping material until the Drum Sander is assembled and running properly.

Compare the contents of your boxes with the following parts list to make sure all parts are intact. Any missing parts should be reported to your distributor. Read this instruction manual thoroughly for assembly, maintenance and safety instructions.

Contents of Boxes

Box #1: (see Figure 2)

- 1 Drum Head Assembly (A)
- 1 TUFTool™ (B)
- 1 Knob (C)
- 1 Depth Gauge Label (D)
- 4 Hex Washer Head Bolts, 5/16"x3/4" (E)
- 1 Sander Demo Video (F)
- 1 Box of Ready To Wrap™ Abrasives (G)
- 1 Instruction Manual (not shown)
- 1 Warranty Card (not shown)

Box #2: (see Figure 3)

- 1 Stand Assembly including:
 - 4 Legs (H)
 - 1 Shelf (J)
 - 2 Long Rails (K)
 - 2 Short Rails (L)
 - 4 Leveling Feet (M)
- 1 Bag of Fasteners including:
 - 24 Carriage Bolts, 5/16"x5/8" (N)
 - 24 Flanged Lock Nuts, 5/16" (O)
 - 8 Hex Nuts, 3/8" (P)
 - 8 Flat Washers, 3/8" (R)
- 1 Conveyor Bed (S)

⚠WARNING Read and understand the entire contents of this manual before attempting set-up or operation! Failure to comply may cause serious injury.

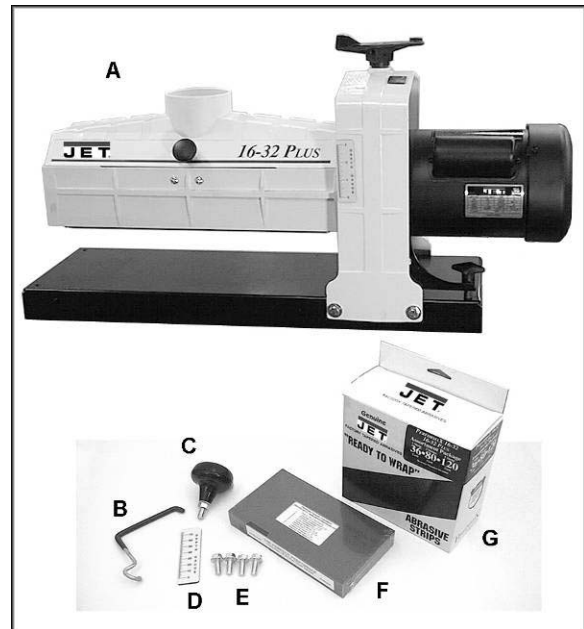

Figure 2 – (Box #1)

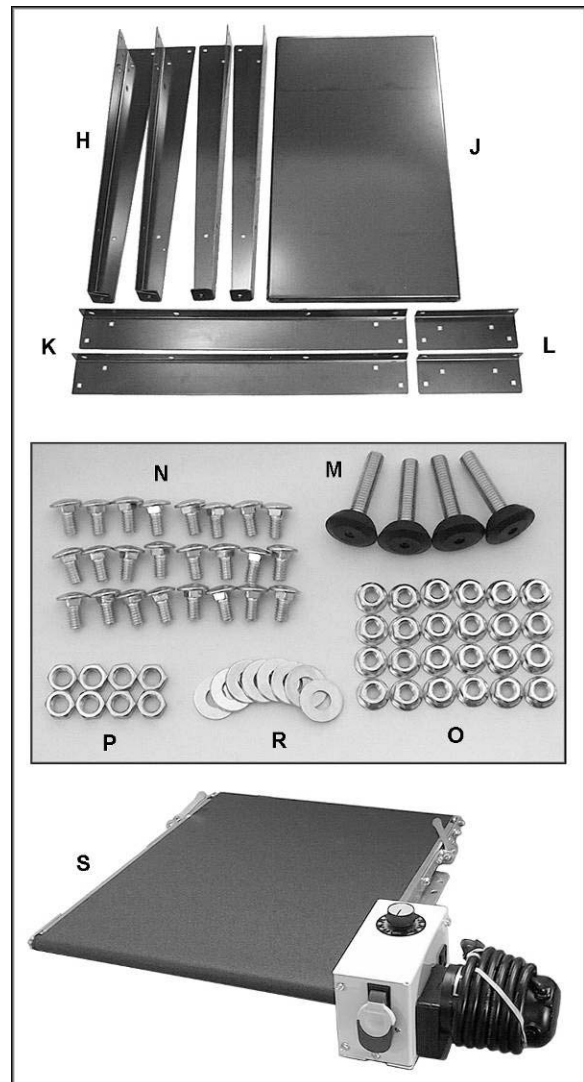

Figure 3 – (Box #2)

Assembling the Stand

(Refer to Figure 4. If further clarification is needed, consult the parts breakdown on page 28.)

Tools required for Stand assembly: Ratchet wrench with 1/2" socket

1. Assemble legs (H) to outside of Short Rails (L) using carriage bolts (N) and flanged lock nuts (O). *Finger tighten only.*
2. Assemble Long Rail (K) on inside of legs and on top of Short Rails (L). *Finger tighten only.* NOTE: Flange of Long Rail (K) overlaps flange of Short Rail (L). See Detail 1 below.
3. Turn stand upside down. Install shelf (J) into legs (H) using carriage bolts and lock nuts.
4. Fully tighten all flanged lock nuts in shelf and legs.
5. If you are using the provided leveling foot (M), place it in bottom hole of leg by placing a hex nut (P) and flat washer (R) above and below the leg flange. If you are mounting the optional casters, see "Casters" below.
6. Turn stand right-side up, and level it using the leveling feet. Tighten the leveling feet hex nuts against the leg flange.

Casters (Optional Accessory)

1. If you are installing the optional casters (see Detail 2 below), press down on the tab to lock the caster, then remove the hex nut and washer with a 19mm wrench. Install the caster through the hole in the stand leg and secure it with the washer and hex nut.
2. Press down with your foot on the large tab to lock a caster; press down on the small tab to unlock it.

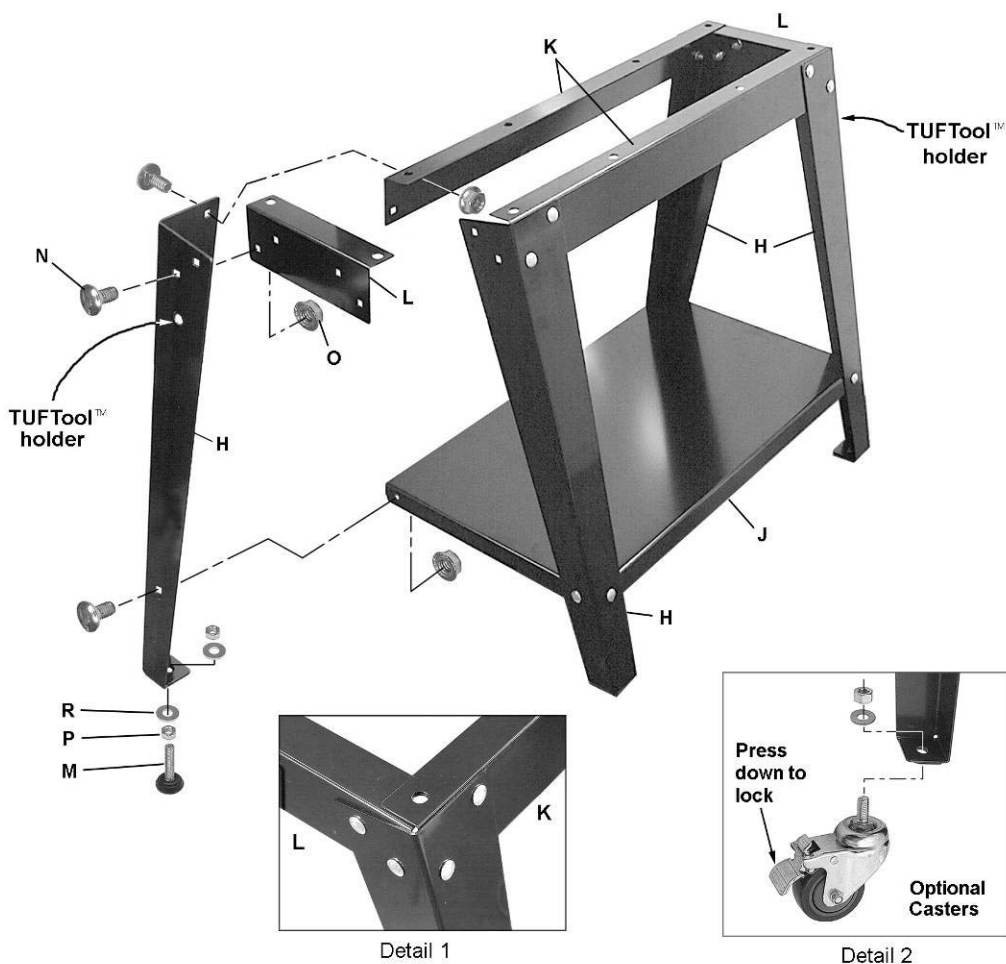

Figure 4

Assembling the Sander

Tools Required for Assembly (not provided):

Ratchet wrench with extension
7/16", 9/16" and 1/2" sockets
9/16" open-end wrench
Flat blade screwdriver

Installing Drum Head

1. Lift the drum head assembly out of the box, and temporarily rest it crosswise on top of the stand. (If your stand has casters, make sure they are locked.)

⚠WARNING The drum head is heavy; use an assistant to help lift if needed.

2. Mount the knob to the height adjustment handle. See Figure 5. Tighten the hex nut against the handle base with a 9/16" wrench.
3. Rotate the height adjustment handle clockwise to raise the drum and free the wood support blocks.
4. Use a 9/16" socket wrench to remove the hex cap screws and flat washers which secure the plywood boards to the bottom of the sander base. Retain these screws and washers for step 6.
5. Position the drum head assembly on top of the stand so that the four threaded holes of the base align with the holes in the long rails of the stand (Figure 6).

[NOTE: The four holes at the center of the long rails are not used with the 16-32 Plus.]

6. Fasten base to stand (from beneath) with the four screws and flat washers that you removed from the plywood boards. See Figure 6. Tighten the screws securely.

Installing Conveyor

1. Raise the sanding drum to its highest elevation by rotating the height adjustment handle (Figure 5) in a clockwise direction.
2. Install the conveyor bed to the base so that the conveyor mounting holes align with the holes in the base. Install four 5/16" hex washer head screws (A, Figure 7).
3. Insert plug of motor cord (B, Figure 7) into the receptacle on the control box.



Figure 5



Figure 6

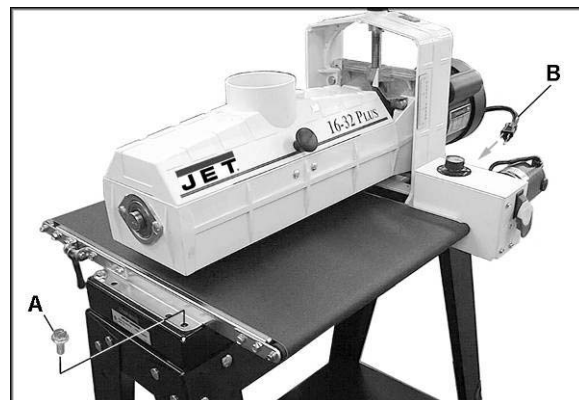

Figure 7

IMPORTANT: The conveyor belt has been *over-tensioned* for shipping purposes. It must be re-tensioned before operating the sander! See “Conveyor Belt Tension/Tracking” on page 16.

Infeed and Outfeed Tables (Optional Accessory)

The sander should be bolted to the stand or a work table when using these table extensions. Maximum working load of each table is 35 pounds.

1. Install a bracket (A, Figure 8) to the two holes in the sander base with a 9/16” wrench, using two hex cap screws (B), two flat washers (C) and two flanged lock nuts (D). The bracket should be flush against the base. Make sure the slotted holes for mounting the table are facing up, as shown in Figure 8. Tighten the flanged lock nuts (D) against the inside of the sander base.
2. Place the table (E, Figure 8) over the bracket and insert four carriage bolts, (F) flat washers (G) and hex nuts (H), as shown. *Finger tighten only.*
3. Position the table slightly below the conveyor belt surface for proper support of stock. To check position, place a straight-edge on one side of the conveyor bed under the sanding drum and extending out over the table. Lower the sanding drum to securely hold the straight-edge in place. See Figure 9. Raise the infeed/outfeed table until the table surface is slightly below the conveyor belt surface. Tighten hex nuts (H, Figure 8) with a 7/16” wrench. Repeat this procedure for other side of table.
4. Install the other bracket and table to the opposite side of the base in the same manner.

NOTE: If after adjusting the infeed/outfeed tables, they are still too high for proper operation, the bracket may not be “set.” To set the bracket, slightly loosen the flanged hex nuts (D, Figure 8) and firmly push down on the bracket. Securely re-tighten the flanged hex nuts.

If the stock being sanded is bowed, warped or otherwise inconsistent, be sure the tables are lower than the top of the conveyor bed.

If stock slips on the conveyor, the tables may be positioned too high. Lower tables to allow stock to remain in contact with the conveyor.

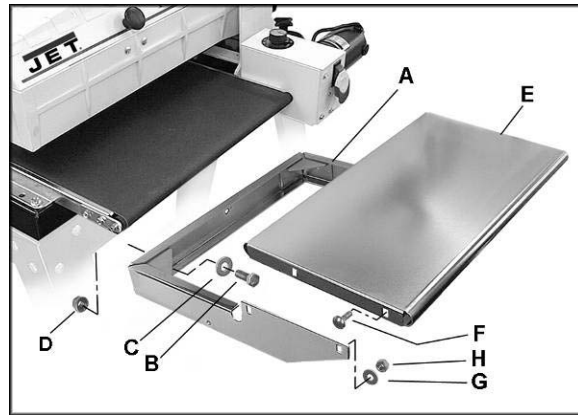

Figure 8



Figure 9

Dust Collection

Dust collection is mandatory for a safe work environment and extended abrasive life. The 16-32 Plus is equipped with a 4" dust collection port at the top of the dust cover. It is designed to be used with standard 4" dust collection hose connected to a high volume dust collector (minimum 400 to 600 cfm).

A standard shop type canister (16 gal. or larger) can be used for short periods of sanding time but requires converting the hose size down to 2-1/2". An adaptor is available for this – see page 27 to order.

Installing Abrasives

An 80-grit abrasive strip is already installed on the drum of your sander, and one box of assorted grit Ready to Wrap™ abrasives is also supplied. Page 26 offers information on the types of abrasive and their recommended uses.

Proper attachment of the abrasive strip to the drum is critical to achieving top performance from your drum sander. Abrasive strips do not have to be pre-measured. The end of the roll is first tapered and attached to the left (outboard) side of the drum. Then the strip is wrapped around the drum, and the second taper is made for attachment to the right (inboard) side of the drum.

NOTE: When using Ready To Wrap™ abrasives, not all of the steps below are necessary. You can use the original abrasive strip mounted to the drum as a template for cutting your own strips.

1. Mark and cut a taper at one end of the roll as shown in Figure 10. Because the tapered end should use all of the left (outboard) slot width, its end must be trimmed back as shown.
2. Squeeze the fastener lever (Figure 11) on the outboard end of drum, and insert the tapered end of the abrasive so that it uses most of the width of the slot. Release the fastener lever to securely hold the strip end to the fastener.
3. Begin wrapping the strip around the drum. The tapered edge of the strip end should follow the edge of the drum.
4. Continue to wrap the abrasive in a spiral fashion by rotating the drum with one hand and guiding the strip with the other (Figure 12). Successive windings of the strip should be flush with previous windings *without any overlap*.

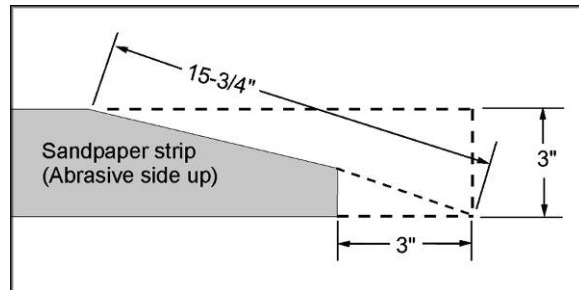

Figure 10

(not applicable to "Ready To Wrap" strips)

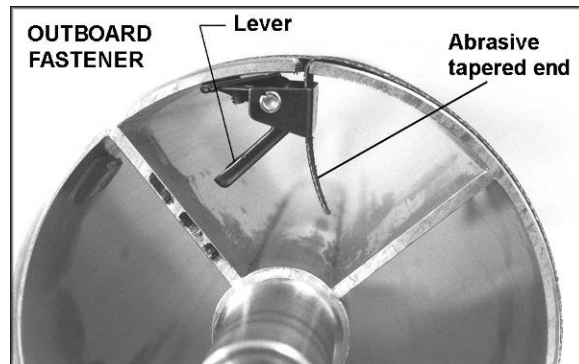

Figure 11



Figure 12

5. Mark the trailing end of the strip where it crosses the right (inboard) end of the drum (Figure 13).
6. Remove the abrasive strip from the drum, and cut a taper as was done with the starting edge (see Figure 10). **Note:** The taper on the remaining roll can be used as the taper for the starting edge of the next strip to be cut.
7. Rewrap the drum beginning at the left, as described in steps 2 through 4 .
8. You can use your fingers to work the infeed take-up fastener, but it will be more convenient to use the TUFTool supplied with your sander. Hold the TUFTool with the red end pointing away from you (Figure 14) and insert its hook into the outside hole of the fastener lever (see Figure 16).
9. Lift the lever with the TUFTool, pulling the lever up until it touches the inside of the drum.
10. Turn the TUFTool counterclockwise and lower it onto the abrasive strip, making sure it is holding the paper tight (Figure 15).

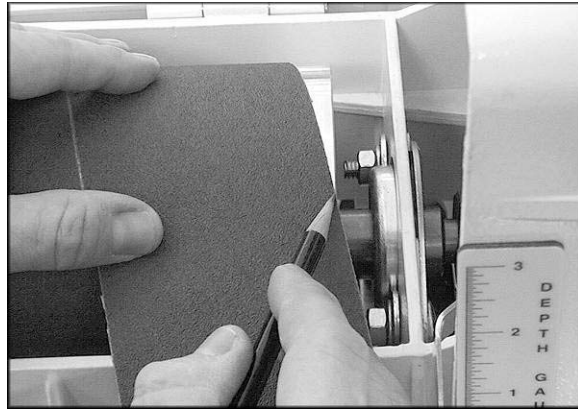

Figure 13

11. Insert the tapered end of the abrasive strip into the slot and fastener. It may be necessary to trim the tapered end of the abrasive strip so that it does not “bottom out” against the inside of the drum.

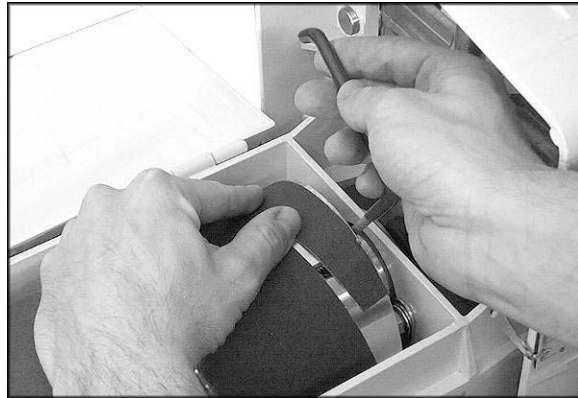

Figure 14

IMPORTANT: Leave a gap – at least 1/8” – between the tapered strip and the closed end of the slot (Figure 15) to allow strip to be pulled into the fastener as needed. If necessary, trim the outside edge of the abrasive strip.

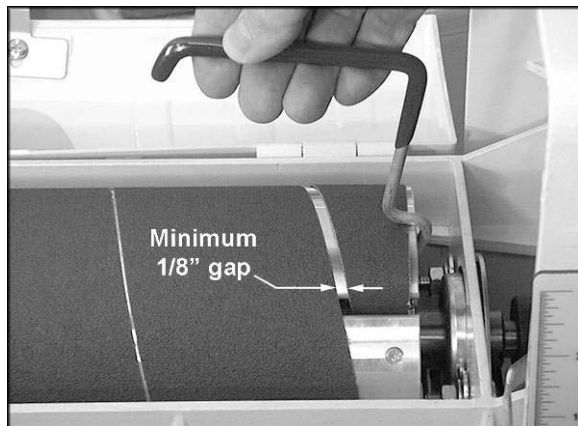

Figure 15

12. Hold the abrasive in place with your left hand, lift up the TUFTool and turn it clockwise while maintaining upward pressure. Slowly move the TUFTool away from you slightly, then down, while easing it out of the hole. This releases the lever in its proper position (Figure 16).

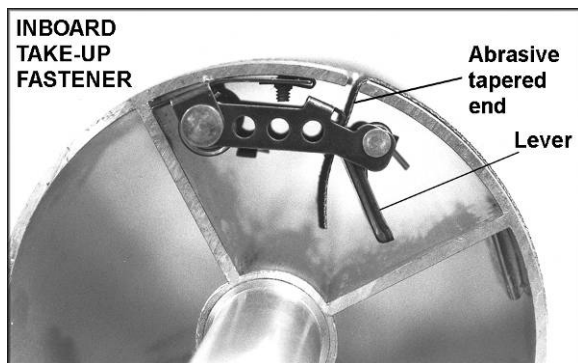

Figure 16

All abrasive strips will stretch in use and may stretch enough to allow the take-up lever to reach its lowest position so that it can not maintain tension on the strip. If this occurs, follow the above procedures to re-set the take-up lever.

Always remove TUFTool from machine before operating.

Grounding Instructions

⚠WARNING Electrical connections must be made by a qualified electrician in compliance with all relevant codes. This machine must be properly grounded to help prevent electrical shock and possible fatal injury.

In the event of a malfunction or breakdown, grounding provides a path of least resistance for electric current to reduce the risk of electric shock. This tool is equipped with an electric cord having an equipment-grounding conductor and a grounding plug. The plug must be inserted into a matching outlet that is properly installed and grounded in accordance with all local codes and ordinances.

Do not modify the plug provided. If it will not fit the outlet, have the proper outlet installed by a qualified electrician.

Improper connection of the equipment-grounding conductor can result in a risk of electric shock. The conductor, with insulation having an outer surface that is green with or without yellow stripes, is the equipment-grounding conductor. If repair or replacement of the electric cord or plug is necessary, do not connect the equipment-grounding conductor to a live terminal.

Check with a qualified electrician or service personnel if the grounding instructions are not completely understood, or if in doubt as to whether the tool is properly grounded. Use only three wire extension cords that have three-prong grounding plugs and three-pole receptacles that accept the tool's plug.

Repair or replace a damaged or worn cord immediately.

As received from the factory, your drum sander is intended for use on a 20 amp, 110V dedicated circuit, which has an outlet and a plug that look like the ones illustrated in Figure 17. A temporary adapter, which looks like the adapter illustrated in Figure 18, may be used to connect this plug to a two-pole receptacle, as shown in Figure 18, if a properly grounded outlet is not available.

The temporary adapter should only be used until a properly grounded outlet can be installed by a qualified electrician. **This adapter is not applicable in Canada.** The green colored rigid ear, lug, or tab, extending from the adapter, must be connected to a permanent ground such as a properly grounded outlet box, as shown in Figure 18.

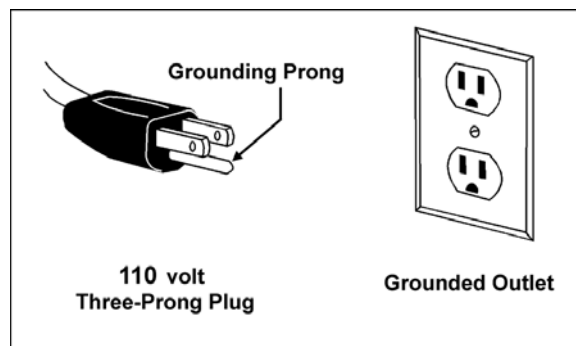

Figure 17

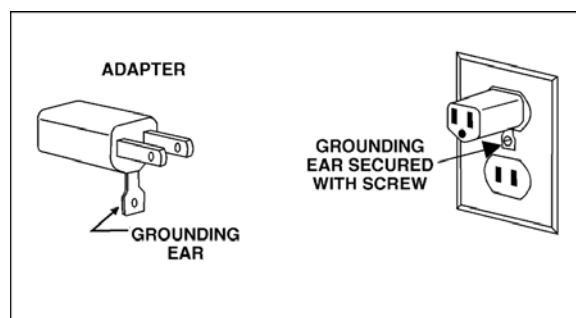

Figure 18

Extension Cords

If an extension cord is necessary, make sure the cord rating is suitable for the amperage listed on the machine's motor plate. An undersize cord will cause a drop in line voltage resulting in loss of power and overheating.

The chart in Figure 19 shows the correct size cord to use based on cord length and motor plate amp rating. If in doubt, use the next heavier gauge. The smaller the gauge number, the heavier the cord.

Adjustments

Drum Height Control

The drum height and depth of cut are controlled by the height adjustment handle (see Figure 5). Rotating the handle counterclockwise lowers the drum, clockwise raises it. One revolution of the handle will move the drum approximately 1/16" (or 1/4 turn = approx. 1/64").

Switch Lock

Unauthorized use of the sander can be prevented by pulling out the key (Figure 20). Press switch to OFF position before removing the key. When the key is removed, the machine can not be started.

To replace the key, slide it back into the switch until it snaps.

Depth Gauge

The depth gauge indicates the distance between the bottom of the sanding drum and the top of the conveyor surface. Adjustment is performed by "zeroing" the gauge.

1. Loosen screw (A, Figure 21) with a 9/16" wrench sufficiently to allow indicator needle (B) to be turned to depth gauge scale (C).
2. With an abrasive strip on the drum, lower sanding drum to where it touches top of conveyor belt.
3. At this drum position, the depth gauge indicator needle (B) should align with the zero mark of the scale. If it does not, loosen screw (A) and raise or lower indicator needle to align with zero on the scale.
4. Re-tighten screw (A).

Recommended Gauges (AWG) of Extension Cords

Amps	Extension Cord Length *					
	25 feet	50 feet	75 feet	100 feet	150 feet	200 feet
< 5	16	16	16	14	12	12
5 to 8	16	16	14	12	10	NR
8 to 12	14	14	12	10	NR	NR
12 to 15	12	12	10	10	NR	NR
15 to 20	10	10	10	NR	NR	NR
21 to 30	10	NR	NR	NR	NR	NR

*based on limiting the line voltage drop to 5V at 150% of the rated amperes.

NR: Not Recommended.

Figure 19

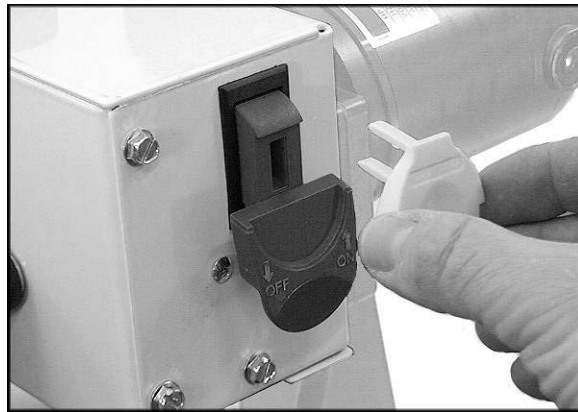

Figure 20

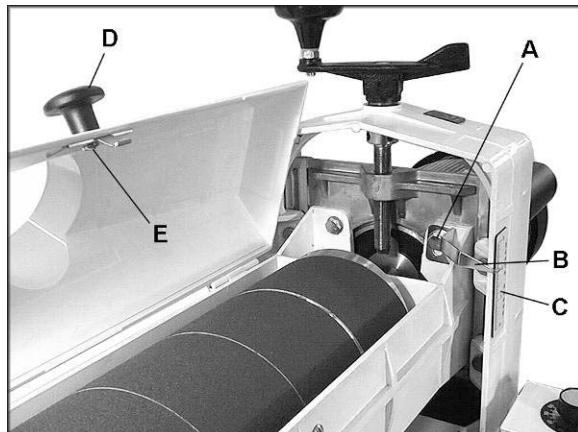

Figure 21

Dust Cover Latch

The dust cover latch prevents the dust cover from accidentally opening. To release the latch, press inward on the dust cover knob (D, Figure 21). This will cause the dust cover center to flex and release the latch. Note that the dust cover latch can be adjusted in or out by loosening the screw (E, Figure 21).

Conveyor Belt Tension/Tracking

Conveyor belt tension and tracking adjustments may occasionally be necessary during break-in and normal operation to compensate for belt stretching.

IMPORTANT: The conveyor belt has been *over-tensioned* for shipping purposes. It must be re-tensioned before operating the sander.

Belt Tension: To adjust the tension of the conveyor belt, first adjust the take-up screw nut (Figure 22) on both sides of the conveyor to obtain approximately equal tension on both sides of the belt when taut.

Insufficient belt tension will cause slippage of conveyor belt on the drive roller during sanding operation. The conveyor belt is too loose if it can be stopped by hand pressure applied directly to the top of the conveyor belt.

Excessive belt tension can cause tracking problems and result in bent rollers, bent take-up brackets, and premature wearing of the bronze roller bearings or conveyor belt.

Belt Tracking: Adjustments to tracking are made while the conveyor belt is running. After the proper belt tension has been achieved, turn on the conveyor unit and set it at the fastest speed setting. Watch for a tendency of the conveyor belt to drift to one side of the conveyor. If there is drifting, tighten the take-up screw nut (Figure 22) on the side toward which the belt is drifting, and loosen the take-up screw nut on the opposite side. **NOTE:** Adjust the take-up screw nuts only 1/4 turn at a time. Then allow time for the belt to react to the adjustments before proceeding further. Try to avoid over-adjustments.

Conveyor Belt Replacement

1. To replace a worn conveyor belt, raise drum to highest position. Unplug machine from power source and unplug motor cord from control box receptacle.
2. Adjust conveyor take-up screw nuts (Figure 22) to relieve belt tension.

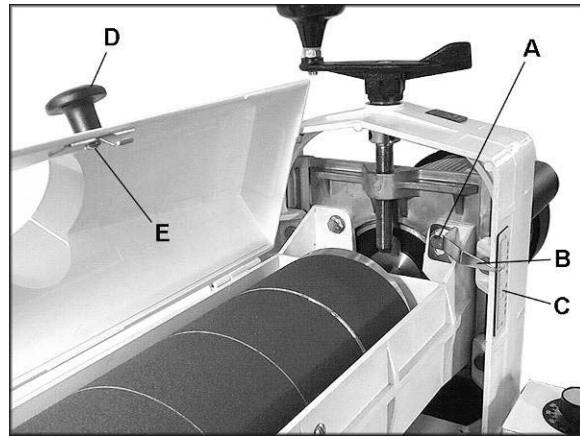

Figure 21 (repeated)

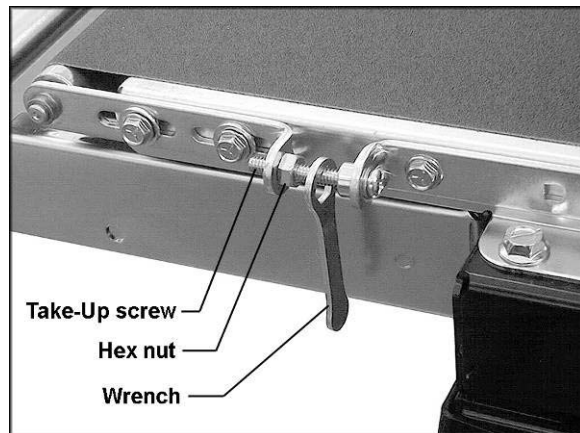

Figure 22

3. Remove the four bolts attaching conveyor assembly to base. Lift up and slide conveyor out to the side of the machine.
4. Set conveyor on motor side and slide conveyor belt off the end of the conveyor bed.
5. Reverse process for installation of new belt.

Sanding Drum Alignment

The sanding drum must be aligned parallel to the conveyor bed for proper machine operation. The sanding drum comes preset from the factory. If a problem with the drum alignment occurs, follow the instructions below.

First inspect the alignment with a gauge of some kind. The following procedure uses a steel straight edge as a gauge.

1. Unplug sander from power source.
2. Open the dust cover and remove the abrasive strip from the drum.
3. Insert the gauge between the drum and conveyor bed at the outer end of the drum (Figure 23). With the dust cover open, lower sanding drum while slowly rotating drum by hand until the drum lightly contacts the thickness gauge.
4. Remove thickness gauge and place under drum at the other end (Figure 24). If the drum does not contact the thickness gauge to the same degree as the opposite end of the drum, alignment is necessary.

To align the drum:

1. Loosen the four 3/8" hex cap screws – two front, two rear (A, Figure 25). This allows the entire drum carriage and shroud to be pivoted on two screws – one screw in front, one in back.
2. Lay the thickness gauge under the drum lengthwise (Figure 26). Rotate the fine tune adjustment knob (B, Figure 25) until the drum contacts the gauge equally along its entire surface. Rotate the knob clockwise to raise the outboard end of the drum, counterclockwise to lower the outboard end of the drum. Use the height adjustment handle to raise or lower the entire drum.
3. When drum is parallel to conveyor, tighten the four screws (A, Figure 25).



Figure 23



Figure 24

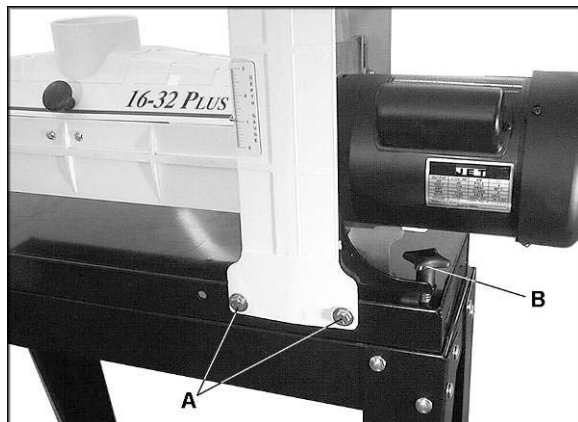

Figure 25

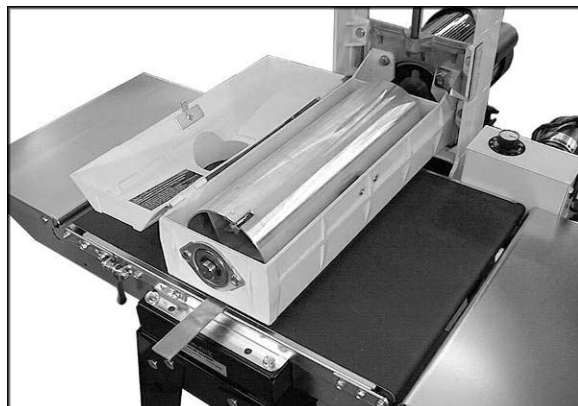

Figure 26

Fine-Tuning Drum Alignment

(for sanding boards wider than the drum)

NOTE: Perform this alignment after you are familiar with sander operation. This is an operational test.

When sanding boards wider than the drum, drum alignment is critical and must be exactly level to slightly high on the outboard end to prevent ridges from forming on the board. Always check this on a piece of scrap wood, as follows, before sanding the work piece.

1. Test alignment with scrap wood roughly 6 inches wide and 20 to 30 inches long. Install abrasive, turn on sander, and pass the board through the sander sideways so that the end of the board extends beyond the end of the drum.
2. Without changing drum height, rotate the board 180° and sand the same side.
3. If a ridge is visible where the drum overlaps, loosen the four screws at front and rear (A, Figure 27 shows the front screws) and raise the outboard end of drum by turning the fine tune adjustment knob (B, Figure 27) slightly clockwise. Re-tighten the four screws.
4. Repeat process until the ridge is eliminated, and the entire board is sanded.

NOTE: Keep track of how many revolutions of the fine tune knob are needed to change drum alignment for wider (over 16") sanding. When sanding narrow stock (less than 16") loosen the four screws (A, Figure 27) and turn the fine tune adjustment knob counterclockwise the same amount as for the initial wide sanding, until the drum is again parallel.

Important: Only turn fine tune adjustment knob when all four screws (A, Figure 27) are loose.

Drum Height Control Adjustment

If the height control mechanism does not operate easily or smoothly, or there is excessive vertical movement or deflection of the drum carriage, perform the following adjustments:

1. With a 1/8" wrench, adjust all four studs by tightening the lock nuts (Figure 28), then loosening them 1/8 to 1/4 turn. If the lock nuts are set too tight, height control will not operate easily. If the lock nuts are too loose, excessive deflection of the outboard end of the drum carriage will result.
2. Apply lubricant to front and rear areas of motor mount slide.
3. Push height adjustment handle (Figure 28) downward to set firmly on housing.

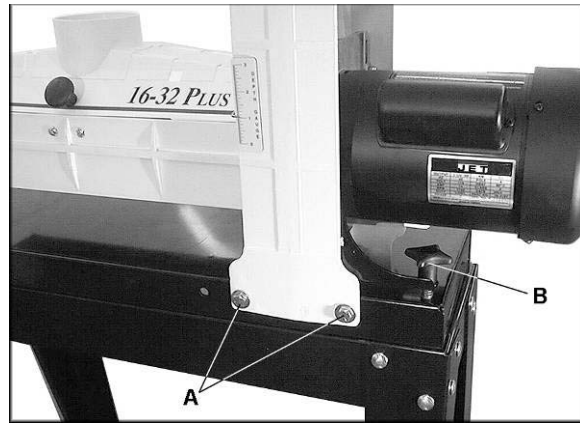

Figure 27

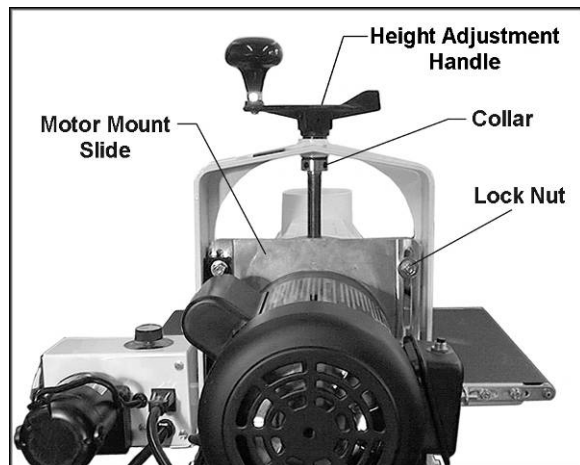

Figure 28

4. Loosen set screws on collar (Figure 28).
5. Slide collar upward against housing so that all vertical free-play of height adjustment screw is eliminated. An easy method of doing this is to use a block of wood on top of the motor mount slide and under the collar, while lowering the drum with the height adjustment handle. Lubricate around washers beneath handle and above collar.

Tension Roller Alignment

The infeed and outfeed rollers are tensioned to provide downward pressure on the workpiece to prevent slippage on the feed conveyor. Tension rollers are set at the factory, but should be inspected and may require adjustment as the sander receives use.

⚠WARNING Improperly adjusted tension rollers (i.e. those set too high, rendering them non-functional) could allow kick-back of pieces being sanded.

1. Unplug sander from power source and remove abrasive from drum.
2. Loosen all four hex nuts on the bearing bolts (A, Figure 29). This will allow both tension rollers to drop to their lowest position. (NOTE: Figure 29 only shows outboard end of drum. Adjustments must be made on *both ends* of drum.)
3. Lower sanding drum to where it contacts the conveyor bed. Then raise the sanding drum by making 3/4 turn of the height adjustment handle.
4. Tighten the four hex nuts (A, Figure 29). Both tension rollers are now positioned about 1/16" below the bottom of the sanding drum.

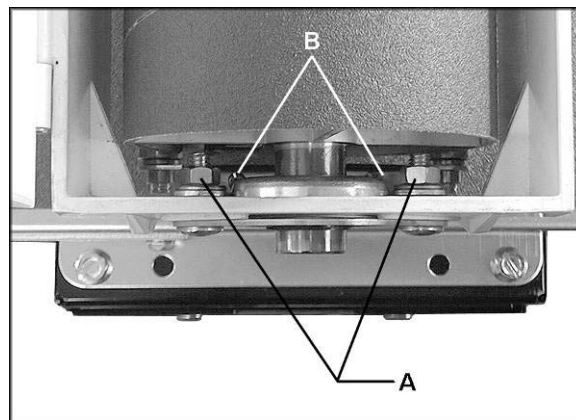

Figure 29

Tension Roller Pressure Adjustment

You can increase or decrease tension roller pressure by turning the screws on the tension roller brackets (B, Figures 29 & 30).

Too much tension roller pressure can result in a "snipe" mark, which is identified as a visible line running across the width of the board and located approximately 2-1/4" from the end of the board.

If the snipe occurs on the leading end of the board, adjust the outfeed tension roller. If the snipe occurs on the trailing end of the board, adjust the infeed tension roller.

Tension roller pressure can also be adjusted by raising the height of the rollers, as follows:

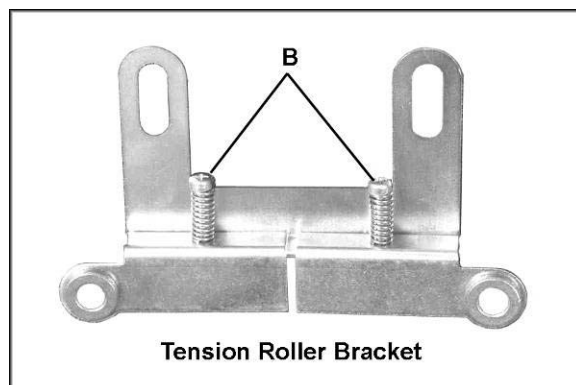

Figure 30

1. Repeat "Tension Roller Alignment" except raise the sanding drum only 1/4 turn of the height adjustment handle.
2. If both tension rollers are causing snipe then tighten all four hex nuts (A, Figure 29) at this position.
3. If only outfeed tension roller causes snipe, only tighten rear (outfeed) hex nuts on each end of drum at this position, then raise sanding drum another 3/4 turn of the handle.
4. Press infeed tension roller down to rest on conveyor bed and tighten front (infeed) hex nuts at this position.

This process sets the tension roller assembly at an angle providing less tension pressure on the outfeed roller.

Operation

Before using your drum sander, review the previous pages in this manual on initial set-up and adjustment. In this section, you will learn how to operate the machine.

Basic Operating Procedure

1. Set depth of cut.
2. Start drum.
3. Start conveyor and select feed rate.
4. Start dust collection system.
5. Feed stock through machine.

Setting Depth of Cut

Adjusting the drum sander for the proper contact between the abrasive and the stock determines the mechanical depth of cut.

It may take some experimentation to determine the proper depth of cut, given the variables of abrasive grit, type of wood, and feed rate. For best results, use scrap wood to practice sanding and to develop skill and familiarity with the machine before doing finish work.

A good rule of thumb when sanding with grits finer than 80 is to lower the drum so it contacts the workpiece but drum can still be rotated by hand. When using grits coarser than 80, you can lower the drum slightly more. However, a combination of several variables will determine the proper depth of cut to use, including the following:

1. Abrasive type and grit size.
2. Width of the piece being processed.
3. Hardness of the piece.
4. Feed rate of the conveyor belt.

Establishing Proper Drum Height

1. To establish drum height, position the stock to be sanded under the drum. Do NOT start drum.
2. Lower the drum to the stock thickness, making sure drum can be rotated by hand while contacting stock.

▲WARNING Do not start drum while in contact with stock!

3. Without changing drum height, turn on conveyor and run the stock out from under the drum. Start sanding drum and sand stock at that same position.
4. With the drum operating, feed stock under the drum from the infeed side and against the rotation of the drum. Always maintain control of the stock to avoid kick-back and/or slippage.

NOTE: If motor heats up during operation, depth of cut may be too great for size of grit and/or feed rate may be too fast.

Selecting SandSmart™ Feed Rates

A faster feed rate allows faster sanding but fewer revolutions of the drum per inch of sanding. A slower feed rate provides more revolutions of the drum per inch of sanding to allow a greater depth of cut and smooth sanding.

Begin experimenting with the feed rate set at about 40% to 50% of maximum. The best feed rate will depend on a number of factors, including type of stock, grit and depth of cut used, and whether the stock is fed directly in line with the conveyor bed or at an angle. If the drum motor is lugging down, if the conveyor belt is slipping, or if you observe a ripple effect on the stock, slow down the feed rate. If the finish is smooth and the machine is not overworking, you can experiment using a faster feed rate.

The SandSmart controller continuously monitors the load on the drum motor, and automatically regulates the speed of the conveyor motor to maintain the highest feed rate without overload.

If the load on the drum motor increases, the SandSmart control will decrease the conveyor feed rate and will stop the conveyor under extreme conditions. If the load on the drum decreases, SandSmart will increase the feed rate but will not increase it faster than the manual setting on the speed adjustment label.

The best and most consistent finish will be achieved if the conveyor does not change speed during operation. When the red indicator light (B, Figure 31) comes on, the SandSmart control has detected too great a depth of cut and/or too fast a feed rate.

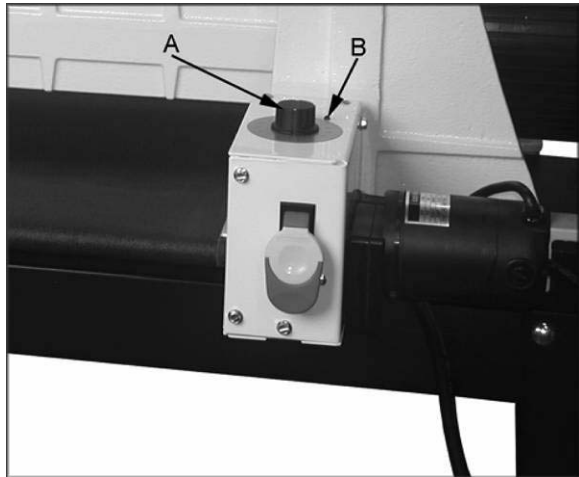

Figure 31

This change in conveyor speed may affect the finish surface. If the finish is affected, make another sanding pass without changing any settings. If the finish is still affected, make adjustments by slowing the conveyor and/or decreasing the depth of cut and run the stock through again.

Also try a faster feed rate or less depth of cut if the stock you are working begins to show burn marks. With cherry, hard maple or other hardwoods, using a shallower depth of cut and a faster feed rate will help minimize burn marks. Slightly angling the stock as it is fed into the machine will also help prevent burning the stock.

Because of the wide range of variables, it is important to experiment with your specific conditions and make adjustments to achieve the optimum feed rate. If problems occur, first check and adjust the feed rate, referring to the "Troubleshooting" sections in this manual.

Tips for Maximum Performance

The versatility designed into the 16-32 Plus drum sander allows it to be used for a wide variety of tasks that will boost the return on your investment. For example, its capabilities range from taking the place of a planer to thickness rough stock, to speeding up fine sanding work often done with slower, dust-generating hand sanders.

Learning how to use its adjustments and controls will allow you to fine-tune the machine for maximum results. The best results come from experimenting with different abrasive grits and machine adjustments to fit the job at hand.

Following is a list of useful tips which can help you improve performance of your sander.

Dust Collection

When connecting dust collectors, remember that straight pipe will not restrict airflow as much as flexible tubing. Y's and elbows will restrict airflow less than T's. Also, a hose smaller than 2-1/2" diameter should not be used.

Multiple-Piece Sanding Runs

When abrasive planing (or thickness sanding) a run of similar pieces that you want to have the same thickness, it is best to determine the thickness of the thinnest piece and process all pieces to that same thickness in one session. Be aware that the sander will remove cups and crowns in the workpiece; consider this when measuring and processing stock to the same thickness.

Sanding Multiple Pieces At Once

When sanding multiple pieces simultaneously, make sure to stagger (step) the pieces across the width of the conveyor belt. This provides better contact with the tension rollers. Try to process only multiple pieces of similar thickness. If there is a significant thickness difference, the thinner pieces can slip on the conveyor belt if they do not contact the tension rollers. Also note that pieces thicker than 3/4" should be longer than the minimum normally recommended to prevent tipping of the stock.

Edge Sanding

When edge sanding, the sander will mimic the opposite edge of the stock which is lying on the conveyor belt. Because of this, it is important for the stock edge to have been ripped at the proper angle to the face before the sanding process. When edge sanding stock that is less than 3/4" wide or more than 2" high, it is good procedure to stack and clamp several pieces together to prevent them from slipping or tipping on the conveyor belt.

Sanding Imperfect Stock

When sanding stock with a cup or crown, place the crown up. This will stabilize the stock to help prevent tipping or rocking during sanding. (After the crown has been removed and the top is flat, turn the stock over and sand the opposite side.) To avoid personal injury, take special care when sanding stock that is twisted, bowed, or otherwise varies in thickness from end to end. If possible, support such stock as it is being sanded to keep it from slipping or tipping. Use extra roller stands, help from another person, or hand pressure on the stock, to minimize potentially hazardous situations.

Face Frames and Raised Panel Doors

It is very important to have the proper abrasive contact when doing this type of sanding. If the machine is set to take an excessive depth of cut, the result can be a gouge or dip as the drum goes from sanding the rails at full width to sanding just a few inches of width on the stiles. To prevent this, make sure that when using abrasives finer than 80 grit the drum is in contact with the wood but can still be spun by hand. If there is room, angling the stock on the conveyor belt can also help. Slowing the conveyor feed when coming to a rail in the stock can help prevent a dip or gouge. This allows the abrasive to work the wider width with less effort, and to achieve better consistency of the finished surface.

Stock Feeding Angle

Some pieces, because of their dimensions, will need to be fed into the machine at a 90° angle (perpendicular to the drums). However, even a slight offset angle of the stock will provide for more effective stock removal. The optimum feeding angle for stock removal is about 60° (see Figure 32).



Figure 32

Angling the workpiece for stock removal provides other advantages, such as less loading of certain areas of the drums due to glue lines or mineral streaks in the stock, more even wear of abrasive strips, potentially faster feed rates, and lighter loads on the motor. Note that to get the best final finish, however, the stock should be fed through the machine so it will be sanded in line with the grain of the wood on the final one or two passes.

Keeping the Machine Clean

For best results, make cleaning the machine a regular shop procedure. Allowing excess build-up of dust and debris can adversely affect performance through the loading of the abrasives, slippage on the conveyor table, and/or the accumulation of material inside the drums which can throw off the center of balance. Leave the dust collector on when cleaning dust from the drums. Also brush the conveyor belt after cleaning operations. If not cleaned, the conveyor belt could allow stock to slip during sanding operations.

Maintenance

⚠WARNING Before doing maintenance on the machine, disconnect it from the electrical supply by pulling out the plug or switching off the main switch! Failure to comply may cause serious injury.

For best results, perform the following recommended procedures on a **monthly** basis:

- Lubricate conveyor bushings and check for wear.
- Lubricate all moving parts, such as threaded rods, washers, and bushings. (Bearings are pre-sealed and require no lubrication.)
- Clean sawdust from the abrasive strip and the conveyor belt.
- Blow dust from motors and switches. Blow dust from inside of sanding drum.
- Check all set screws for tightness on parts such as bearings, conveyor and couplings.

Tracker Kit (98-0080)

Trackers dramatically reduce tracking adjustments of conveyor belts. They are already installed on your sander. The following information is for re-setting or replacing your trackers, should that become necessary. Refer to Figure 33.

1. Disconnect power to sander, and disconnect motor cord from control box receptacle.
2. Raise drum as far as it will go.
3. Loosen the conveyor take-up screw nuts to relieve conveyor belt tension and slide driven roller fully inward. Slide conveyor belt to one side of bed.
4. Remove the four bolts holding the conveyor table to the sander base.
5. Lift conveyor bed and slide it out of the sander. Turn conveyor bed upside down. Be careful not to damage the conveyor belt.
6. On the underside of the conveyor bed, there are U-channels welded to the bed. The Tracker is positioned on the inside of the first U-channel on the infeed side of sander (the U-channel closest to the rubber covered drive roller and gear motor). The back of the Tracker is magnetized and will stick to the side wall of the conveyor bed. Do not install Tracker if the edge of the conveyor belt is damaged or torn.
7. With the first Tracker installed, slide the conveyor belt into the bottom slot of the Tracker. **Note:** When installed properly, only the bottom lip of the Tracker will be visible. The top slot is to be used if the bottom slot wears out.
8. Install second Tracker opposite the first. Use both Trackers unless the second one does not fit in conveyor or if conveyor belt is damaged.
9. Turn conveyor bed right side up and reposition the bed onto the base. Re-attach the four mounting bolts and tighten. **Caution:** Be careful not to knock Tracker(s) out of conveyor bed when turning conveyor over.
10. Make sure all switches are off. Connect power to sander and plug in motor.
11. Tension conveyor belt using take-up screw nuts. If both Trackers are installed, it is very important to have equal tension on both sides of the conveyor belt. Tighten both sides of take-up screw nuts until equal tension is obtained.
12. To check tension, turn on conveyor full speed and place both hands on conveyor. If conveyor belt can be stopped, continue tensioning until conveyor belt cannot be stopped by both hands on the belt while the conveyor is operating at full speed.
13. Make sure conveyor belt runs smoothly inside Tracker slot and that magnet is holding the Tracker in position.
14. Continue to watch tracking of conveyor and adjust only if necessary, making sure to keep equal tension on conveyor belt at all times and not allowing conveyor belt to buckle under conveyor bed.

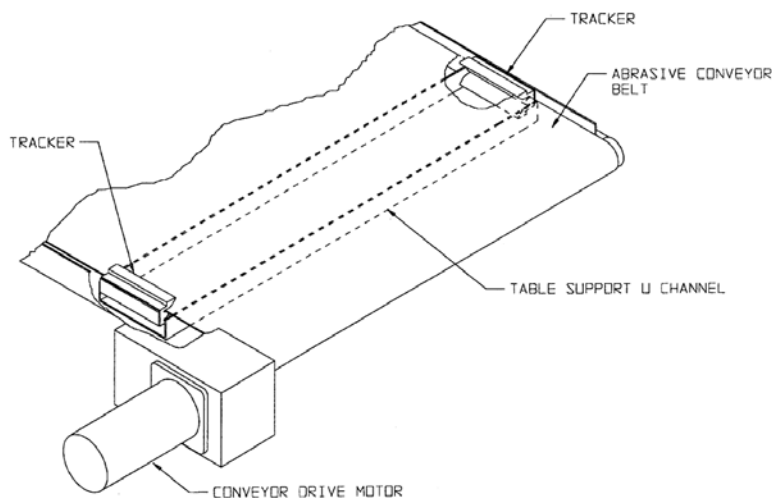

Figure 33 (underside of conveyor shown)

Troubleshooting

Trouble	Probable Cause	Remedy
Sander will not start.	No incoming power.	Check plug connection. Make sure fuse is not blown/circuit breaker is not tripped. Push the circuit breaker button on the sander motor to re-set.
	Switch is malfunctioning.	Replace switch.
Conveyor motor stalls.	Excessive depth of cut.	Reduce depth of cut; use coarser grit; reduce feed rate.
Conveyor belt does not move.	Shaft coupler is loose or unattached.	Adjust shaft coupler.
Conveyor rollers run intermittently.	Shaft coupling is loose.	Align the shaft flats of the gear motor and the drive roller and tighten the shaft-coupling setscrews.
Abrasive strip comes off drum.	Slack in abrasive strip on drum.	Remove slack in strip.
	Abrasive improperly wrapped.	Read the section on installing abrasives, pages 12-13.
Abrasive strip is loose.	Strip caught on inside edge of slot, or on inboard side of drum.	Re-adjust the strip end in the slot and/or trim the abrasive edge.
	Strip not cut properly.	Re-cut and re-install the abrasive strip.
Abrasive loads up prematurely.	Excessive depth of cut.	Reduce depth of cut.
	Excessive feed rate.	Reduce feed rate.
	Inadequate dust collection.	Increase airflow at dust port.
	Inadequate abrasive.	Use an open-coat abrasive.
Line or groove in stock.	Inconsistent feed rate.	Do not stop or change the feed rate while feeding stock.
Snipe marks.	Improper tension on rollers.	Re-tension rollers (see page 19).
Sander burns wood.	Abrasive strip is overlapped.	Re-wrap abrasive strip (page 12-13).
	Abrasive is loaded.	Clean abrasive.
	Depth of cut excessive for fine grit.	Use coarser grit or reduce depth of cut.
	Feed rate too slow.	Increase feed rate.
	Abrasive is worn.	Replace abrasive.
Conveyor belt slips on drive roller.	Improper conveyor belt tension.	Adjust belt tension (page 16).
	Excessive depth of cut and/or feed rate.	Reduce depth of cut and/or feed rate.

Trouble	Probable Cause	Remedy
Board slips on conveyor belt.	Tension rollers too high.	Lower tension rollers (see page 19).
	Excessive feed rate.	Reduce feed rate.
	Dirty or worn conveyor belt.	Replace conveyor belt.
Sander motor slows or stalls.	Improper conveyor belt tension.	Adjust belt tension. If necessary, reduce depth of cut and/or feed rate.
	Excessive depth of cut and/or excessive feed rate.	Reduce depth of cut or feed rate.
Ripples in sanded surface. A. Non-uniformly spaced ripples. B. Uniformly spaced ripples.	A. Uneven feed rate.	Conveyor belt slipping (see above) Board slips on conveyor belt (see above). Conveyor motor stalls (see above).
	B. Conveyor bed flexing or vibration.	Reduce depth of cut and/or feed rate. Check for loose bolts, loose shaft coupling set screws, or out-of-balance drum.
Wood is gouged.	Stock slipping on conveyor.	Correct depth of cut or roller tension.
	Work piece not properly supported.	Add work supports for long work pieces.
Table height adjustment works improperly.	Improper adjustment of height control.	Readjust height control. See pages 18-19.

Abrasives

The abrasive material you choose will have a substantial effect on the performance of your sander. Variations in paper type, weight, coating and durability all contribute to achieving your desired finish.

JET Abrasives are available in Ready-To-Wrap™ pre-cut lengths or in the convenient Ready-To-Cut pre-marked box. Your JET dealer can recommend the best choice for your application.

Selecting Drum Abrasives

It is important to select the proper grit of abrasives for the type of sanding being performed to achieve maximum sanding results. As with any sanding operation, first begin sanding with a coarser grit, depending upon the roughness of the stock or the amount of stock to be removed. Then progressively work toward finer grits. The chart (Figure 34) shows the general uses for the various grits. JET offers abrasives in most of the different grits shown – consult the stock numbers on page 27 to order.

The amount of stock to be removed is a major consideration when choosing the grit grade to start with. Grits 24, 36, 50 and 60 are primarily designed for stock removal. Grits 24 and 36 will remove the most material in one pass, whether you are doing abrasive planing, cleaning up glued panels, or flattening stock. Grits from 100 through 220 are primarily finishing grits designed to remove the scratch pattern from the previous grit used. For best results, never skip more than one grit grade when progressing through a sanding sequence.

For fine work, such as furniture, try not to skip any grit grades during the sanding process. In general, premium quality abrasives will produce a better finish with a less noticeable scratch pattern.

NOTE: Grits that are too fine can sometimes burnish the wood and leave a glossy surface which will not accept stains evenly. This will vary by type of wood. Oak, for example, is susceptible to burnishing because of its open pores.

Cleaning Abrasive Strips

Regularly clean the abrasive strips on the drums with commercially available cleaning sticks, following the manufacturer's directions. Cleaning sticks are available from your JET dealer. When cleaning, also brush the stick crumbs from the drum while it is still rotating.

CAUTION Always wear eye protection while performing sandpaper cleaning, and take all precautions to avoid any contact of hands or clothing with uncovered rotating drums.

Cloth-backed abrasives can be cleaned by soaking in paint thinner or mineral spirits for 20 minutes to 1 hour, then using a brush to remove any build-up or burns. Dry the abrasive strips completely before using.

Increasing Abrasive Life

Abrasive life can be increased not only by cleaning, but by removing the abrasive strip from the drum and reversing it. To do this, remove the strip and use what was the trailing end as the starting end on the left (outboard) side of the drum. Reversing the strip will provide a fresh set of cutting edges on the abrasive.

Abrasive Selection Guide

<u>Grit</u>	<u>Common Application</u>
24Abrasive planing, surfacing rough-sawn boards, maximum stock removal, glue removal.
36Abrasive planing, surfacing rough-sawn boards, maximum stock removal, glue removal.
50Surfacing and dimensioning boards, trueing warped boards
60Surfacing and dimensioning boards, trueing warped boards.
80Light dimensioning, removal of planer ripples.
100Light surfacing, removal of planer ripples.
120Light surfacing, minimal stock removal.
150Finish sanding, minimal stock removal.
180Finish sanding only, not for stock removal.
220Finish sanding only, not for stock removal.

Figure 34

Optional Accessories

98-0130	Locking Casters, set of 4
98-1601	Infeed/Outfeed Tables
60-6000	Ready-To-Wrap™ Assortment Package, Grits: 36 (1 strip), 80 (2 strips), 120 (1 strip)
60-6036	Ready-To-Wrap™ Abrasive Strip, 36 Grit, (4 wraps in a box)
60-6060	Ready-To-Wrap™ Abrasive Strip, 60 Grit, (4 wraps in a box)
60-6080	Ready-To-Wrap™ Abrasive Strip, 80 Grit, (4 wraps in a box)
60-6100	Ready-To-Wrap™ Abrasive Strip, 100 Grit, (4 wraps in a box)
60-6120	Ready-To-Wrap™ Abrasive Strip, 120 Grit, (4 wraps in a box)
60-6150	Ready-To-Wrap™ Abrasive Strip, 150 Grit, (4 wraps in a box)
60-6180	Ready-To-Wrap™ Abrasive Strip, 180 Grit, (4 wraps in a box)
60-6220	Ready-To-Wrap™ Abrasive Strip, 220 Grit, (4 wraps in a box)
60-9036	Premium Ready-To-Cut™ Abrasive Strip, 36 Grit
60-9060	Premium Ready-To-Cut™ Abrasive Strip, 60 Grit
60-9080	Premium Ready-To-Cut™ Abrasive Strip, 80 Grit
60-9100	Premium Ready-To-Cut™ Abrasive Strip, 100 Grit
60-9120	Premium Ready-To-Cut™ Abrasive Strip, 120 Grit
60-9150	Premium Ready-To-Cut™ Abrasive Strip, 150 Grit
60-9180	Premium Ready-To-Cut™ Abrasive Strip, 180 Grit
60-9220	Premium Ready-To-Cut™ Abrasive Strip, 220 Grit

*All of the above abrasive strips are 3" wide, cloth backed, aluminum oxide, resin bond, open coat.

Replacement Parts

Replacement parts are listed on the following pages. To order parts or reach our service department, call 1-800-274-6848, Monday through Friday (see our website for business hours, www.waltermeier.com). Having the Model Number and Serial Number of your machine available when you call will allow us to serve you quickly and accurately.

Conveyor and Motor Assembly

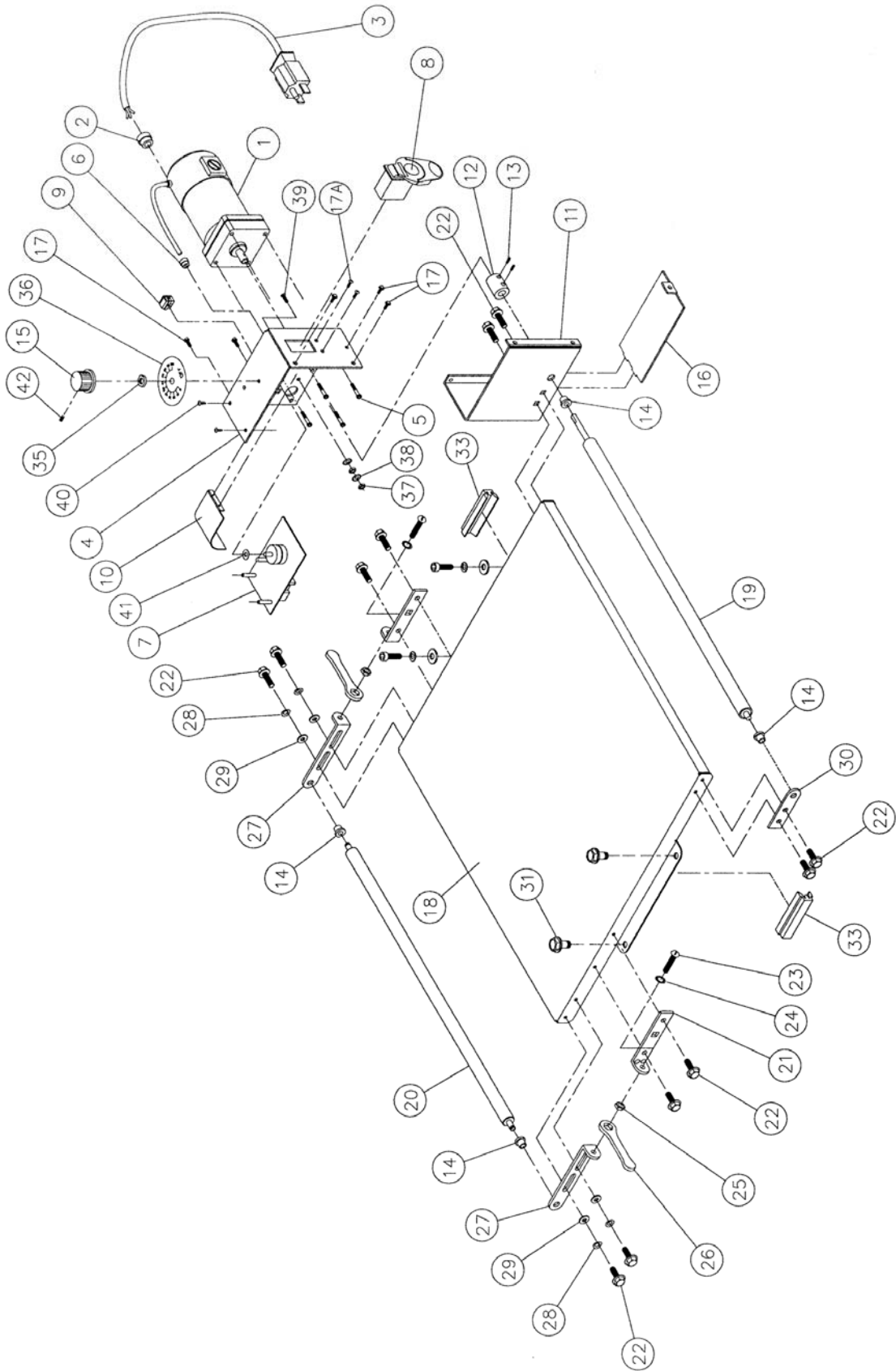

Parts List: Conveyor and Motor Assembly

Index No.	Part No.	Description	Size	Qty
1	3237359	Gear Motor	90 VDC	1
2	72-6014	Large Strain Relief		1
3	72-5336	Cord Set	115V – 75"	1
4	40-4904	Control Housing Bracket		1
5	TS-0206022	Socket Head Cap Screw	#10-32x1/2"	4
6	72-6101	Small Strain Relief		1
7	72-2250	SandSmart Controller		1
8	JSG96-135	On/Off Drum Switch		1
9	72-2120	Receptacle	115V	1
10	40-4018	Wiring Guard		1
11	40-4903	Controller Base Bracket		1
12	30-0122	Shaft Coupler		1
13	10-2702	Socket Head Set Screw	#10-32x1/4"	2
14	50-3105	Oil-Lite Bushing	I.D. 5/16"	4
15	72-2250-01	Knob		1
16	40-4022W	Control Housing Base Cover		1
17	10-9002	Hex Head Slotted Screw	#10-32x1/2"	5
17A	10-3103	Phillips Pan Head Machine Screw	#6-32x1/2"	2
18	40-4010	Conveyor Bed		1
19	30-3050-01	Drive Roller		1
20	30-3010-01	Driven Roller		1
21	41-0004	Take-Up Base Bracket		2
22	10-9010	Hex Washer Head Bolt	1/4"-20x3/4"	12
23	10-3213	Slotted Round Head Screw	1/4-20x1-3/4"	2
24	11-0504	Lock Washer, Internal Tooth	1/4"	2
25	TS-0570011	Hex Nut	1/4"-20	2
26	40-0260	Wrench		2
27	41-0003	Take-Up Slide Bracket		2
28	20-1161	Wave Washer	1/4"	4
29	TS-0680021	Flat Washer	1/4"	4
30	40-0005	Drive Roller Support Bracket		1
31	10-9106	Hex Washer Head Bolt	5/16"-18x3/4"	4
32	60-0316-P	Conveyor Belt (not shown)	100 grit	1
33	98-0080	Tracker Kit		1
35	72-2250-04	Hex Nut	5/16"-24	1
36	72-2250-02	Speed Adjustment Label		1
37	TS-0560081	Hex Nut	#10-32	2
38	TS-073203	Lock Washer, Internal Tooth	#10	2
39	TS-081D022	Pan Head Machine Screw	#10-32x1/2"	1
40	20-0777	Pan Head Self-Tapping Screw	5/32x1/2"	2
41	72-2250-03	Flat Washer	5/16	1
42	72-2250-05	Slotted Set Screw	#8-36UNFx5/16"	1

Drum Head Assembly

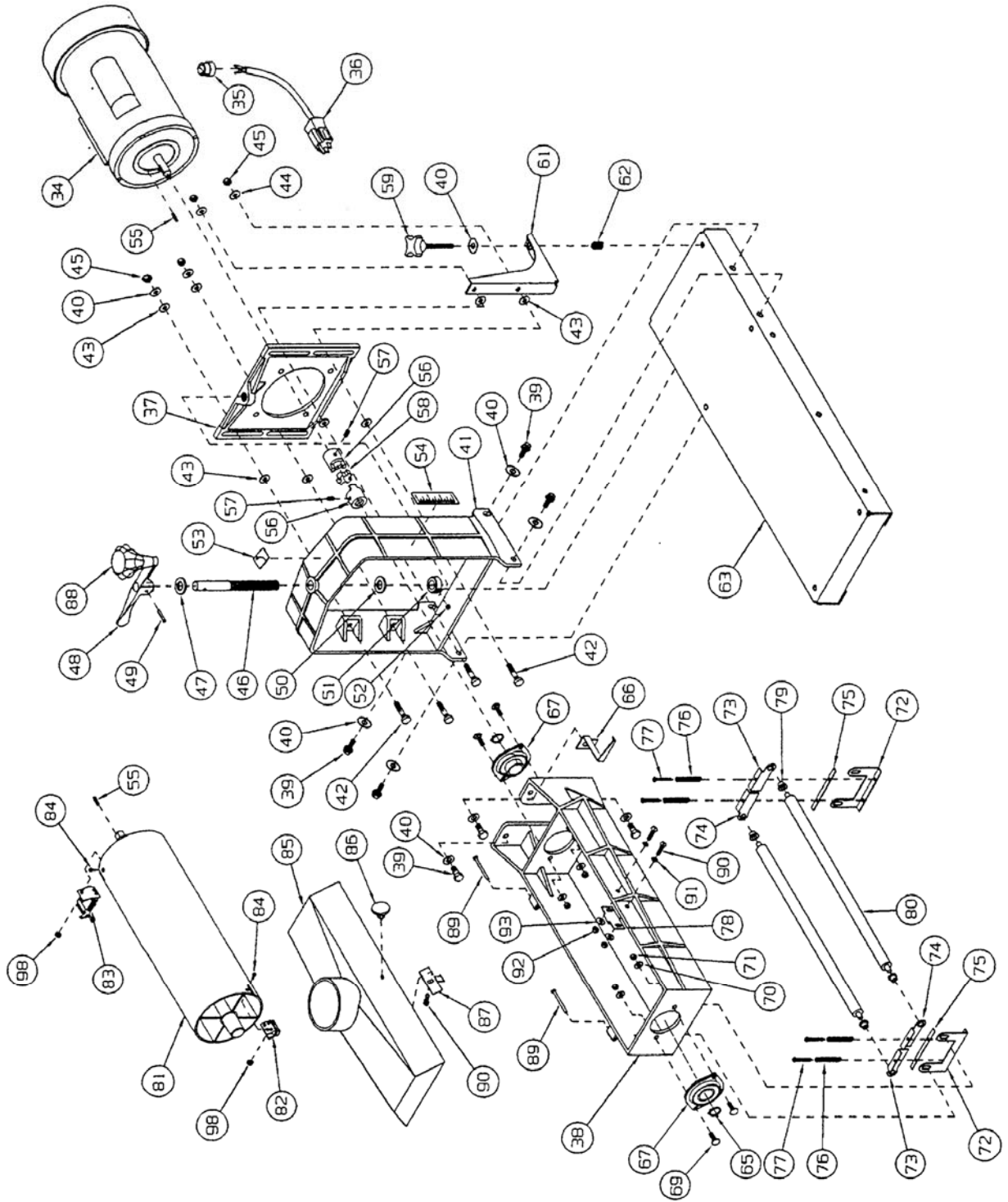

Parts List: Drum Head Assembly

Index No.	Part No.	Description	Size	Qty
34	70-4101A	Motor	1-1/2HP, 110-120V	1
	70-4101-1	Motor Fan (not shown)		1
	70-4101-2	Motor Fan Cover (not shown)		1
	C-300125A	Capacitor (not shown)	300MFD, 125VAC	1
35	72-6104	Large Strain Relief		1
36	72-5343	Cord Set		1
37	30-3018	Motor Mount Slide		1
38	30-3016-02	Drum Carriage		1
39	TS-0060061	Hex Cap Screw	3/8-16x1-1/4"	8
40	6861201	Wrought Washer	5/16"	13
41	30-6000-02	Shroud		1
42	30-3028	Stud		4
43	50-3076	Oil-Lite Washer	I.D. 5/16"	8
44	11-0510-05	Washer	I.D. 5/16" (small O.D.)	2
45	TS-0640082	Nylon Lock Hex Nut	5/16"-24	4
46	30-3012	Height Adjustment Screw		1
47	50-3080	Oil-Lite Washer	I.D. 5/8"	1
48	30-0021	Height Adjustment Handle		1
49	6626029	Roll Pin	3/16x1"	1
50	80-2324	Nylon Flat Washer	I.D. 5/8"	1
51	20-1104	Shaft Locking Collar	I.D. 5/8"	1
52	10-4020-04	Socket Head Set Screw (Collar)	5/16"-18x1/4"	1
53	94-1668	Height Direction Label		1
54	94-1670	Depth Gauge		1
55	20-0762	Key Stock	3/16" Sq. x 3/4"	2
56	50-2207	Drum Shaft Coupling		2
57	10-8802	Socket Head Set Screw	1/4"-20x1/4"	2
58	50-2209	Spider		1
59	80-3136	Adjusting Knob		1
61	40-4006	Drum Adjusting Bracket		1
62	20-3216	Spring		1
63	40-4005	Power Feed Bed Base		1
65	20-0753	Retaining Ring		2
66	40-3167	Depth Gauge Needle		1
67	50-3089	Drum Bearing		2
69	10-1205	Carriage Bolt	5/16"-18x1"	4
70	TS-0680031	Flat Washer	5/16"	8
71	6515001	Hex Nut	5/16"-18	4
72	40-0304	Tension Roller Bracket		2
73	41-0302	Tension Roller Suspension Bracket – Right		2
74	41-0303	Tension Roller Suspension Bracket – Left		2
75	80-1060	Tension Roller Bracket Pad		2
76	20-3211	Tension Roller Spring		4
77	10-3108	Phillips Fillister Head Screw	#8-32x1"	4
78	40-3166	Dust Cover Catch		1
79	50-3105	Oil-Lite Bushing	I.D. 5/16"	4
80	30-3051-01	Tension Roller		2
81	2148003	Sanding Drum		1
82	21-1173	Outboard Abrasive Fastener		1
83	21-1172	Inboard Abrasive Take-Up Fastener		1
84	10-4009-06	Phillips Flat Head Machine Screw	#6-32x3/8"	2
85	80-2002	Dust Cover		1
86	80-3137	Dust Cover Knob		1
87	40-3168	Dust Cover Latch		1
88	80-3131	Height Adjustment Knob		1
89	20-0775	Hinge Pin		2
90	10-4007-10	Slotted Round Head Screw	1/4"-20x5/8"	3

91	11-1000-04	Lock Washer, Internal Tooth	1/4"	2
92	TS-0561011	Hex Nut	1/4"-20	2
93	TS-0680021	Flat Washer	1/4"	2
94	98-0010	Handle Kit (includes index #46,48,49) (not shown)		
95	51-2200	Coupler Kit (includes index #56,67,58) (not shown)		
98	12-9001	Nylon Insert Lock Nut	#6-32	1
99	98-0060	TufTool™ (not shown)		1
	99-1002	16-32 Sander Demo Video (not shown)		1

Parts List: Infeed/Outfeed Tables (Optional Accessory)

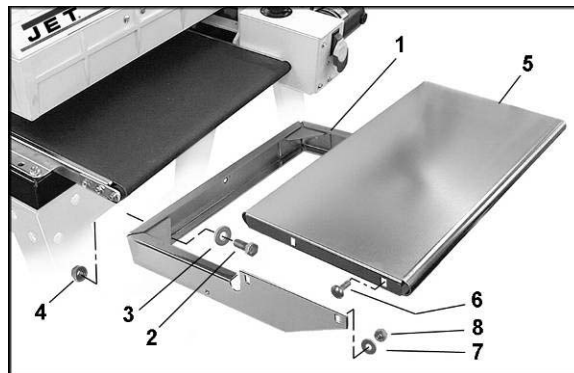

Index No.	Part No.	Description	Size	Qty
	98-1601	Infeed/Outfeed Tables, 16"		
1	40-0330	Table Bracket		2
2	10-9205	Hex Cap Screw	3/8-16x1"	4
3	11-9103	Flat Washer, Hardened	5/16"	4
4	12-0209	Flanged Lock Nut	3/8"-16	4
5	40-0331	Extension Table		2
6	6714264	Carriage Bolt	1/4-20x3/4"	8
7	6861107	Flat Washer	1/4"	8
8	6514001	Hex Nut	1/4"-20	8

Parts List: Stand Assembly

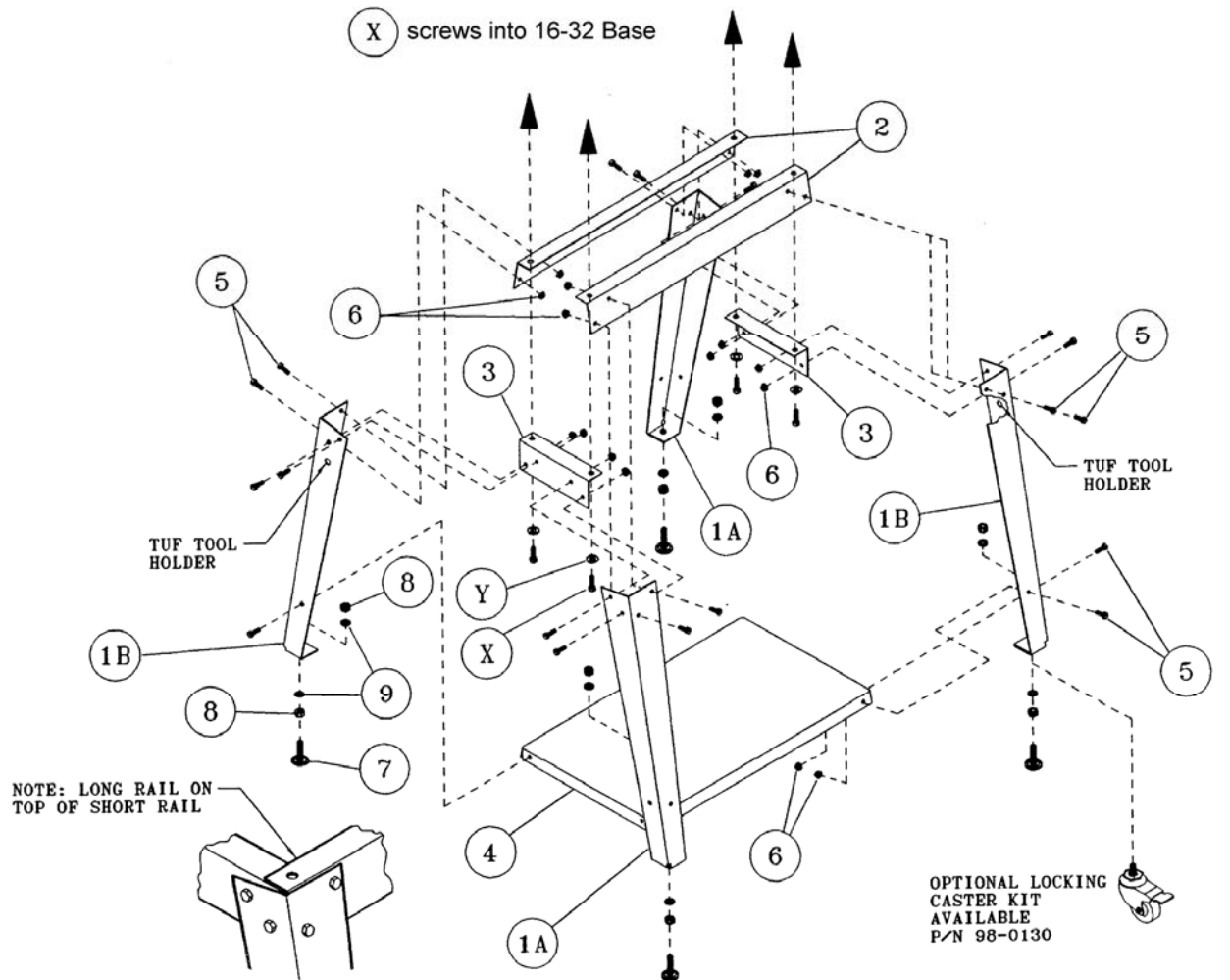

Index No.	Part No.	Description	Size	Qty
1A.....	40-4040.....	Left Leg.....		2
1B.....	40-4041.....	Right Leg (with TufTool holder).....		2
2.....	40-4042.....	Long Rail.....		2
3.....	40-4043.....	Short Rail.....		2
4.....	98-1610.....	Shelf.....		1
5.....	10-1206.....	Carriage Bolt.....	5/16"x5/8"	24
6.....	12-0207.....	Flanged Lock Nut.....	5/16"	24
7.....	20-0655.....	Leveling Foot.....		4
8.....	TS-0561031.....	Hex Nut.....	3/8"	8
9.....	TS-0680041.....	Flat Washer.....	3/8"	8

Electrical Connections

GEARMOTOR CONTROLLER SCHEMATIC
110V AC TO VARIABLE 90V DC

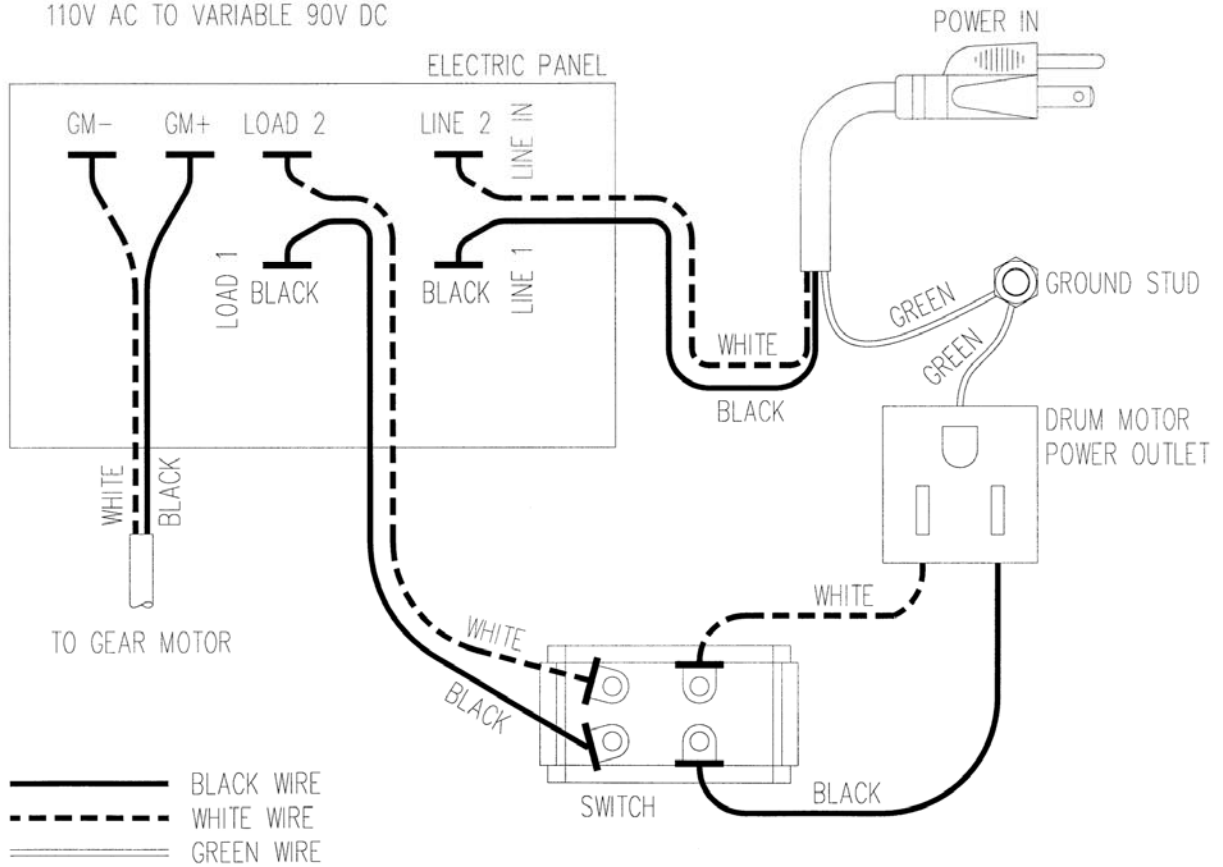



WALTER MEIER (Manufacturing) Inc.

427 New Sanford Road
LaVergne, Tennessee 37086
Phone: 800-274-6848
www.waltermeier.com