

JET[®]

Operating Instructions and Parts Manual Oscillating Drum Sander Model 22-44OSC



For machines with serial no. 11121604 and higher

WALTER MEIER (Manufacturing) Inc.
427 New Sanford Road
LaVergne, Tennessee 37086
Ph.: 800-274-6848
www.waltermeier.com

Part No. M-659006K
Revision C 12/2011
Copyright © 2011 Walter Meier (Manufacturing) Inc.

Warranty and Service

Walter Meier (Manufacturing) Inc., warrants every product it sells. If one of our tools needs service or repair, one of our Authorized Service Centers located throughout the United States can give you quick service. In most cases, any of these Walter Meier Authorized Service Centers can authorize warranty repair, assist you in obtaining parts, or perform routine maintenance and major repair on your JET® tools. For the name of an Authorized Service Center in your area call 1-800-274-6848.

MORE INFORMATION

Walter Meier is consistently adding new products to the line. For complete, up-to-date product information, check with your local Walter Meier distributor, or visit waltermeier.com.

WARRANTY

JET products carry a limited warranty which varies in duration based upon the product (MW = Metalworking, WW = Woodworking).

90 DAY WARRANTY	1 YEAR WARRANTY	Body Repair Kits Bottle Jacks Cable Pullers Cold Saws Hoists-Air Hoists-Electric Metal forming Mill/Drills Milling Machines MW Bandsaws MW Drill Presses MW Finishing Equipment MW Lathes MW Precision Vises	2 YEAR WARRANTY	Palet Trucks Rigging Equip. Service Jacks Stackers Surface Grinders Tapping Trolleys-Air Trolleys-Electric Web Slings Winches-Electric	3 YEAR WARRANTY	WW Benchtop Tools	Beam Clamps Chain Hoist- Manual Lever Hoists Pullers-JCH Models Scissor Lift Tables Screw Jacks Trolleys-Geared Trolleys-Plain Winches-Manual WW Air Filtration WW Bandsaws WW Buffers	5 YEAR WARRANTY	WW Drill Presses WW Dust Collectors WW Dust Filters WW Dust Fittings WW Jointers WW Lathes WW Planers WW Sanders WW Shapers WW Tablesaws	LIFE LIFETIME WARRANTY	Fastening Tools Mechanics Hand Tools Striking Tools Vises (no -precision) Clamps
<i>Warranty reverts to 1 Year Warranty if woodworking (WW) products listed above are used for industrial or educational purposes.</i>											

WHAT IS COVERED?

This warranty covers any defects in workmanship or materials subject to the exceptions stated below. Cutting tools, abrasives and other consumables are excluded from warranty coverage.

WHO IS COVERED?

This warranty covers only the initial purchaser of the product.

WHAT IS THE PERIOD OF COVERAGE?

The general JET warranty lasts for the time period specified in the product literature of each product.

WHAT IS NOT COVERED?

Five Year Warranties do not cover woodworking (WW) products used for commercial, industrial or educational purposes. Woodworking products with Five Year Warranties that are used for commercial, industrial or education purposes revert to a One Year Warranty. This warranty does not cover defects due directly or indirectly to misuse, abuse, negligence or accidents, normal wear-and-tear, improper repair or alterations, or lack of maintenance.

HOW TO GET SERVICE

The product or part must be returned for examination, postage prepaid, to a location designated by us. For the name of the location nearest you, please call 1-800-274-6848.

You must provide proof of initial purchase date and an explanation of the complaint must accompany the merchandise. If our inspection discloses a defect, we will repair or replace the product, or refund the purchase price, at our option. We will return the repaired product or replacement at our expense unless it is determined by us that there is no defect, or that the defect resulted from causes not within the scope of our warranty in which case we will, at your direction, dispose of or return the product. In the event you choose to have the product returned, you will be responsible for the shipping and handling costs of the return.

HOW STATE LAW APPLIES

This warranty gives you specific legal rights; you may also have other rights which vary from state to state.

LIMITATIONS ON THIS WARRANTY

WALTER MEIER (MANUFACTURING) INC., LIMITS ALL IMPLIED WARRANTIES TO THE PERIOD OF THE LIMITED WARRANTY FOR EACH PRODUCT. EXCEPT AS STATED HEREIN, ANY IMPLIED WARRANTIES OR MERCHANTABILITY AND FITNESS ARE EXCLUDED. SOME STATES DO NOT ALLOW LIMITATIONS ON HOW LONG THE IMPLIED WARRANTY LASTS, SO THE ABOVE LIMITATION MAY NOT APPLY TO YOU.

WALTER MEIER SHALL IN NO EVENT BE LIABLE FOR DEATH, INJURIES TO PERSONS OR PROPERTY, OR FOR INCIDENTAL, CONTINGENT, SPECIAL, OR CONSEQUENTIAL DAMAGES ARISING FROM THE USE OF OUR PRODUCTS. SOME STATES DO NOT ALLOW THE EXCLUSION OR LIMITATION OF INCIDENTAL OR CONSEQUENTIAL DAMAGES, SO THE ABOVE LIMITATION OR EXCLUSION MAY NOT APPLY TO YOU.

Walter Meier sells through distributors only. The specifications in Walter Meier catalogs are given as general information and are not binding. Members of Walter Meier reserve the right to effect at any time, without prior notice, those alterations to parts, fittings, and accessory equipment which they may deem necessary for any reason whatsoever. JET®-branded products are not sold in Canada by Walter Meier.

Table of Contents

Warranty and Service.....	2
Table of Contents	3
Warning	4
Introduction	6
Specifications	6
Features and Terminology.....	7
Unpacking.....	8
Shipping Contents	8
Assembly	9
Stand Assembly	9
Drum Head Installation	10
Conveyor Table Installation.....	10
Installing Accessories.....	10
Infeed and Outfeed Tables.....	10
Dust Cover.....	11
Dust Collection.....	11
Installing Abrasives.....	11
Grounding Instructions.....	13
Extension Cords.....	13
Operating Controls.....	14
On/Off Switch (Sanding Drum)	14
Switch Lockout.....	14
Conveyor	14
Drum Height Control.....	14
Oscillator Switch.....	14
Adjustments	15
Depth Gauge	15
Conveyor Belt Tension and Tracking	15
Trackers	15
Conveyor Belt Replacement.....	16
Checking Drum Alignment.....	16
Fine Tuning Drum Alignment.....	17
Tension Roller Alignment	17
Tension Roller Pressure Adjustment	18
Drum Height Control Adjustment	18
Operation.....	19
Basic Operating Procedure	19
Setting Depth of Cut	19
Establishing Proper Drum Height.....	19
Selecting SandSmart™ Feed Rates	19
Tips for Maximum Performance.....	20
Maintenance	21
Tracker Kit	22
Abrasives	23
Abrasive Selection Guide.....	23
Optional Accessories	24
Troubleshooting.....	24
Troubleshooting – Motor and Electrical Problems	24
Troubleshooting – Mechanical Problems.....	25
Troubleshooting – Operational Problems	26
Replacement Parts	26
Drum Head Assembly – Exploded View	27
Drum Head Assembly – Parts List	28
Conveyor and Motor Assembly – Exploded View.....	30
Conveyor and Motor Assembly – Parts List.....	31
Gearbox Assembly	32
Closed Stand Assembly	33
Infeed and Outfeed Tables.....	34
Wiring Diagram.....	35

Warnings

1. Read and understand this entire manual before attempting assembly or operation.
2. Read and understand the warnings posted on the machine and in this manual. Failure to comply with all of these warnings may cause serious injury.
3. Replace the warning labels if they become obscured or removed.
4. This sander is designed and intended for use by properly trained and experienced personnel only. If you are not familiar with the proper and safe operation of a sander, do not use until proper training and knowledge have been obtained.
5. Do not use this sander for other than its intended use. If used for other purposes, Walter Meier (Manufacturing) Inc., disclaims any real or implied warranty and holds itself harmless from any injury that may result from that use.
6. Always wear approved safety glasses/face shields while using this sander. Everyday eyeglasses only have impact resistant lenses; they are not safety glasses.
7. Before operating this sander, remove tie, rings, watches and other jewelry, and roll sleeves up past the elbows. Remove all loose clothing and confine long hair. Non-slip footwear or anti-skid floor strips are recommended. Do not wear gloves.
8. Wear ear protectors (plugs or muffs) during extended periods of operation.
9. Some dust created by power sanding, sawing, grinding, drilling and other construction activities contain chemicals known to cause cancer, birth defects or other reproductive harm. Some examples of these chemicals are:
 - Lead from lead based paint.
 - Crystalline silica from bricks, cement and other masonry products.
 - Arsenic and chromium from chemically treated lumber.Your risk of exposure varies, depending on how often you do this type of work. To reduce your exposure to these chemicals, work in a well-ventilated area and work with approved safety equipment, such as face or dust masks that are specifically designed to filter out microscopic particles.
10. Do not operate this machine while tired or under the influence of drugs, alcohol or any medication.
11. Make certain the switch is in the OFF position before connecting the machine to the power supply.
12. Make certain the machine is properly grounded.
13. Make all machine adjustments or maintenance with the machine unplugged from the power source.
14. Remove adjusting keys and wrenches. Form a habit of checking to see that keys and adjusting wrenches are removed from the machine before turning it on.
15. Keep safety guards in place at all times when the machine is in use. If removed for maintenance purposes, use extreme caution and replace the guards immediately.
16. Make sure the sander is firmly secured to the stand or work table before use.
17. Check damaged parts. Before further use of the machine, a guard or other part that is damaged should be carefully checked to determine that it will operate properly and perform its intended function. Check for alignment of moving parts, binding of moving parts, breakage of parts, mounting and any other conditions that may affect its operation. A guard or other part that is damaged should be properly repaired or replaced.
18. Provide for adequate space surrounding work area and non-glare, overhead lighting.
19. Keep the floor around the machine clean and free of scrap material, oil and grease.
20. Keep visitors a safe distance from the work area. Keep children away.

Warnings

21. Make your workshop child proof with padlocks, master switches or by removing starter keys.
22. Give your work undivided attention. Looking around, carrying on a conversation and “horse-play” are careless acts that can result in serious injury.
23. Maintain a balanced stance at all times so that you do not fall or lean against moving parts. Do not overreach or use excessive force to perform any machine operation.
24. Stand to one side of the conveyor and make sure no one else is standing in line with the conveyor while feeding into the machine. Should a part slip while being fed, it may exit the machine at a high rate of speed and can cause injuries to anyone standing directly in front of the infeed.
25. Use the right tool at the correct speed and feed rate. Do not force a tool or attachment to do a job for which it was not designed. The right tool will do the job better and safer.
26. Use recommended accessories; improper accessories may be hazardous.
27. Maintain tools with care. Keep abrasives clean for the best and safest performance. Follow instructions for lubricating the machine and changing accessories.
28. Always feed stock against the rotation of the drum.
29. Keep your hands clear when feeding parts onto the conveyor. The part will be forced down as it begins to feed, causing a pinching action between the part and the conveyor bed. Never reach into a running machine. Turn off sander and disconnect from power before attempting to retrieve parts from beneath the drum.
30. Turn off the machine and disconnect from power before cleaning. Use a brush or compressed air to remove chips or debris — do not use your hands.
31. Do not stand on the machine. Serious injury could occur if the machine tips over.
32. Never leave the machine running unattended. Turn the power off and do not leave the machine until it comes to a complete stop.
33. Remove loose items and unnecessary work pieces from the area before starting the machine.

Familiarize yourself with the following safety notices used in this manual:

CAUTION This means that if precautions are not heeded, it may result in minor injury and/or possible machine damage.

WARNING This means that if precautions are not heeded, it may result in serious injury or possibly even death.

- - SAVE THESE INSTRUCTIONS - -

Introduction

This manual is provided by Walter Meier (Manufacturing) Inc., covering the safe operation and maintenance procedures for a JET Model 22-44OSC Oscillating Drum Sander. This manual contains instructions on installation, safety precautions, general operating procedures, maintenance instructions and parts breakdown. This machine has been designed and constructed to provide years of trouble free operation if used in accordance with instructions set forth in this manual. If there are any questions or comments, please contact either your local supplier or Walter Meier. Walter Meier can also be reached at our web site: www.waltermeier.com.

Specifications

Model Number.....	22-44OSC
Stock Numbers:	
Sander Kit complete	659006K
Sander Only.....	659006
Conveyor.....	649003-02
Stand	659006S
Maximum Width (in.)	44 (two passes)
Minimum Length (in.)	2-1/4
Maximum Thickness (in.).....	4
Minimum Thickness (in.)	1/32
Conveyor Height from Floor (in.)	32
Drum Size (in.)	5 x 23 Extrusion, Aluminum
Drum Speed (RPM)	1700
Dust Chute (in.)	4
Conveyor Motor.....	1/30HP, 0.45A, 40 RPM, 43 inch-lb. torque, direct drive D.C.
Conveyor Variable Feed Rate (FPM)	0-10 (SandSmart)
Drum Motor.....	TEFC, Induction, capacitor start, 1-3/4HP, 1Ph, 115V only, 15.5A, 60Hz
Overall Dimensions, assembled (in.)	44L x 27W x 52H
Net Weight (lbs.).....	336
Shipping Weight (lbs.).....	363

The above specifications were current at the time this manual was published, but because of our policy of continuous improvement, Walter Meier reserves the right to change specifications at any time and without prior notice, without incurring obligations.

Features and Terminology

The illustration below shows the major components and features of the 22-44OSC Sander. These are referenced throughout the manual and will help to familiarize you with the operation and functions of the machine.

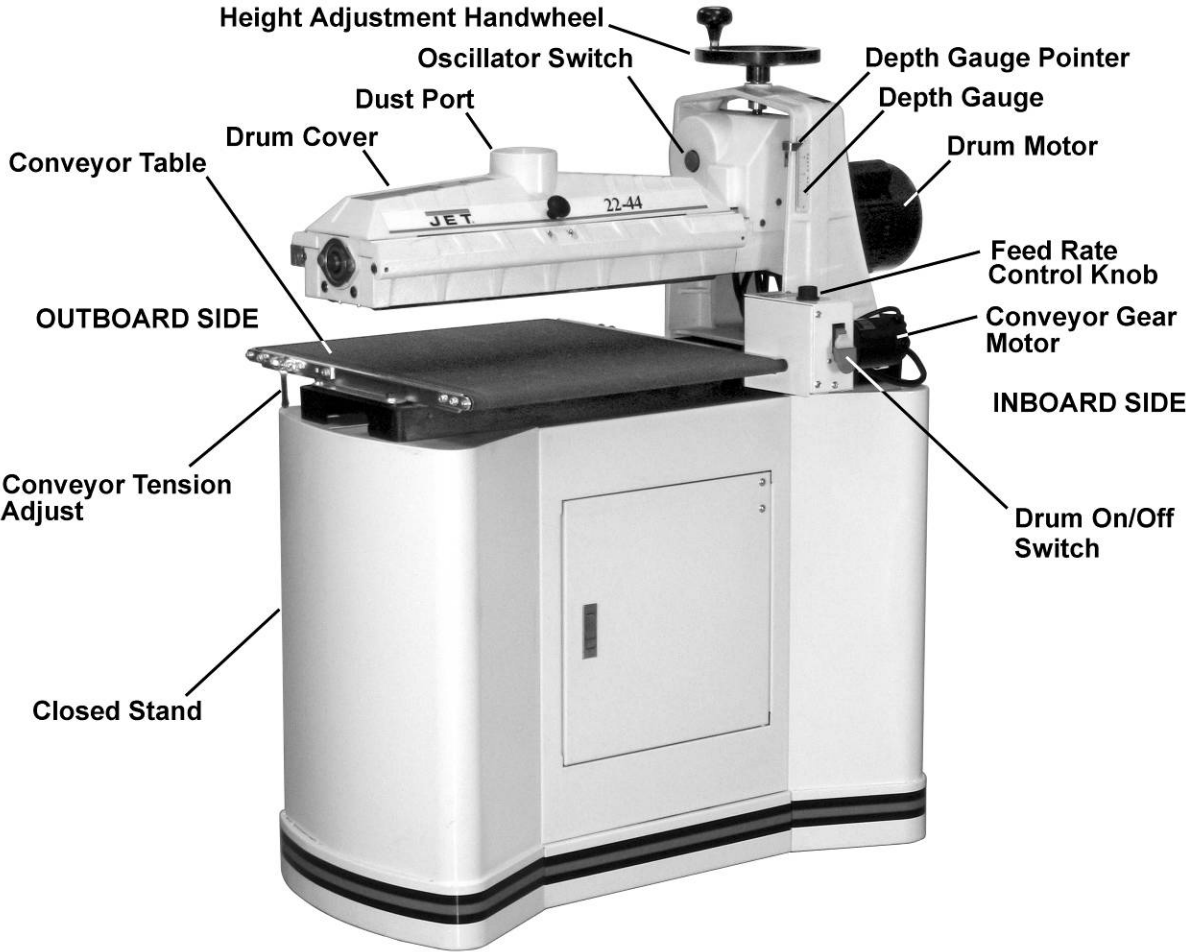

Figure 1 – Features

Unpacking

Open shipping container and check for shipping damage. Report any damage immediately to your distributor and shipping agent. Do not discard any shipping material until the Drum Sander is assembled and running properly.

Compare the contents of your container with the following parts list to make sure all parts are intact. Missing parts, if any, should be reported to your distributor. Read the instruction manual thoroughly for assembly, maintenance and safety instructions.

Note: The letter designators identifying parts on this page are used throughout the *Assembly* section of this manual for reference convenience.

Shipping Contents

Main Container Contents

Contents shown in Figure 1

- 1 Handwheel (A)
- 1 TufTool (B)
- 1 Drum Head (C)
- 1 Conveyor Table Assembly (D)
- 1 Bottom Plate (E)
- 2 Stand Side (F)
- 1 Rear Plate (G)
- 1 Front Plate (H)
- 1 Hardware Bag (see below for contents)
- 1 Owner's Manual (not shown)

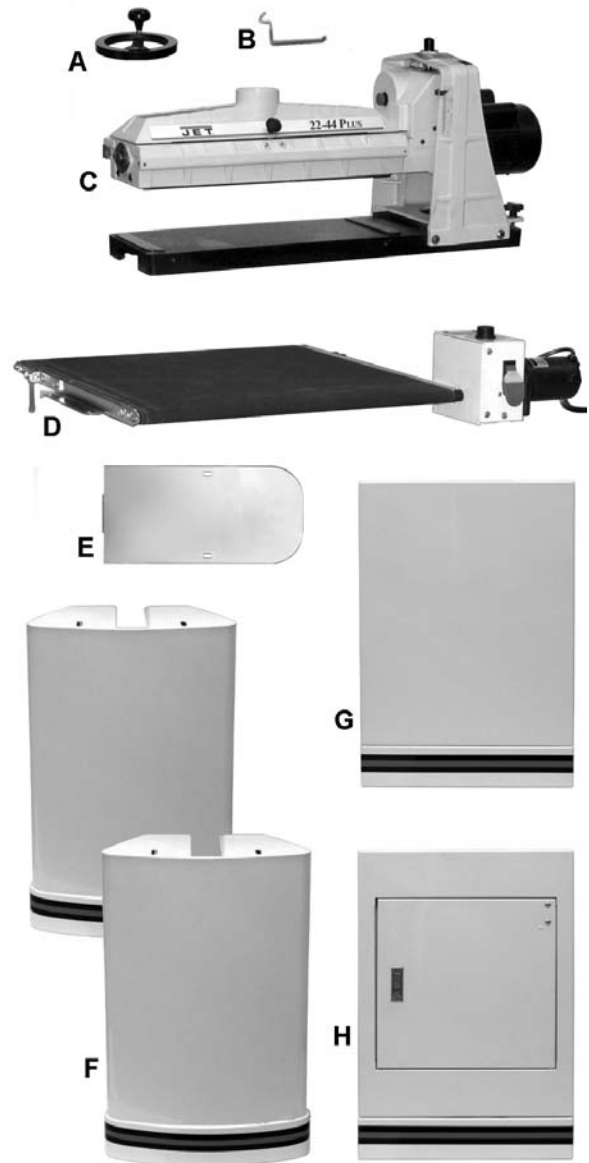
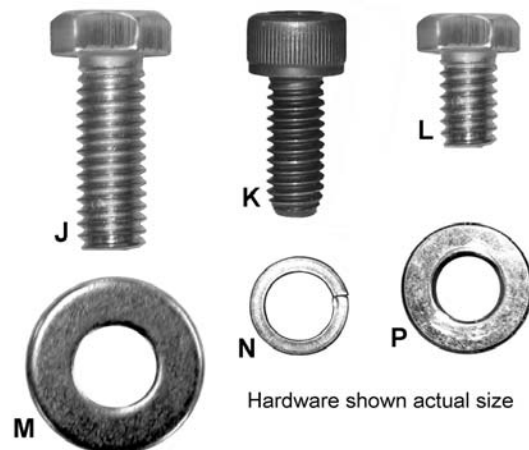

Figure 2 – Main Container Contents

Hardware Bag Contents

Note: The letter designators identifying parts on this page are used throughout this manual for reference convenience.

- 4 Hex Cap Screw, 3/8"x1" (J)
- 4 Socket Head Cap Screw, 5/16"x3/4" (K)
- 12 Hex Cap Screw, 5/16"x1/2" (L)
- 4 Flat Washer, 3/8" (M)
- 4 Lock Washer, 5/16" (N)
- 16 Flat Washer, 5/16" (P)
- 3 Hex Wrenches, 1/8", 4mm and 6mm (not shown)



Hardware shown actual size

Figure 3 – Hardware Bag Contents

Assembly

Stand Assembly

1. Position two *stand sides* (F₁, F₂) on the ground with the base down, about 3 feet apart with the openings toward the center.
2. Mount the *bottom plate* (E) to the *stand sides* with four each 5/16" *hex cap screws* (L₁) and 5/16" *flat washers* (P₁). Hand-tighten only at this time.
3. Secure the left side of the *rear plate* (G) to the *left stand side* (F₁) with two each 5/16" *hex cap screws* (L₂) and 5/16" *flat washers* (P₂). Hand-tighten only.
4. Secure the right side of the *rear plate* (G) to the *right stand side* (F₂) in the same manner as above. Hand-tighten only.
5. Secure the *front plate* (H) to the left and right *stand sides* (F₁, F₂) in the same manner as above with four each 5/16" *hex cap screws* (L) and 5/16" *flat washers* (P). Hand-tighten only.

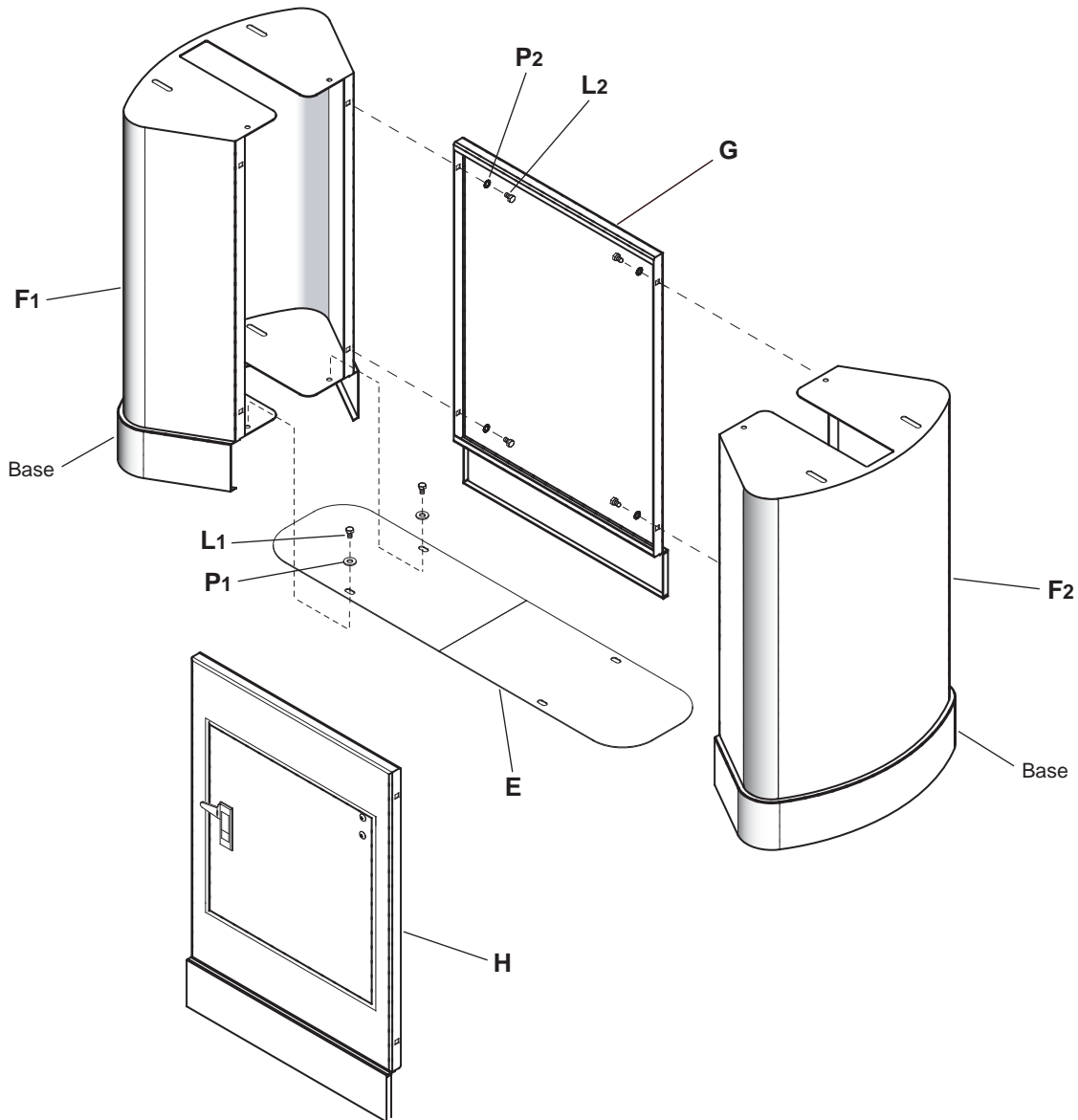

Figure 4

Drum Head Installation

Tools required for assembly:

- 1 Flat head screwdriver
- 1 Set of open-end wrenches
- 1 Set of Hex wrenches
- 1 Adjustable wrench

Referring to Figure 5:

1. Place the *sander* (C) onto the stand previously assembled.

CAUTION The sander is very heavy. Use a hoist or assistance when moving to avoid injury to self and equipment.

Align the four threaded *mounting holes* of the *sander base* (C₁) with the slotted holes on the stand.

2. Secure the *sander* (C) to the stand from inside the cabinet using four 3/8" x 1" hex cap screws (J) and four 3/8" flat washers (M).
3. Attach the *handwheel* (A) to the *height adjustment screw* (C₂), and tighten the two set screws with the 4mm hex wrench supplied.

After installing the drum head to the stand, finish tightening all mounting hardware that was previously hand-tightened during the stand assembly.

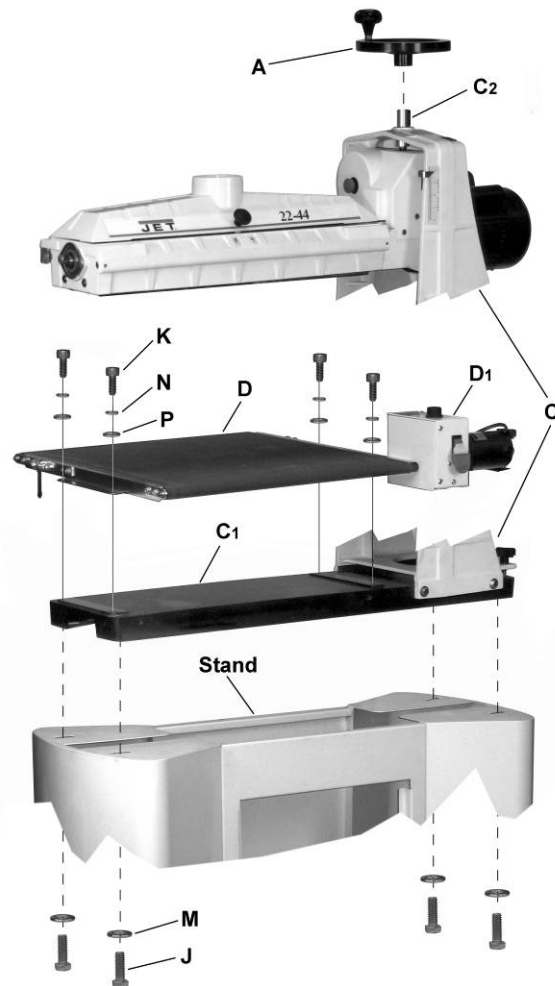

Figure 5

Conveyor Table Installation

1. Raise the drum as far as it will go by turning the *handwheel* (A) clockwise.

2. Place the *conveyor* (D) onto the sander base (C₁).

Align the four holes in the *conveyor* (D) with the four holes in the *sander base*.

3. Secure the conveyor in place with four 5/16" x 3/4" socket head cap screws (K), four 5/16" lock washers (N) and four 5/16" flat washers (P).
4. Plug the sander's motor cord into the receptacle of the *control box* (D₁).

Important: The conveyor belt has been *overtensioned* for the purpose of shipping. Before operation, adjust the belt tension (see page 15).

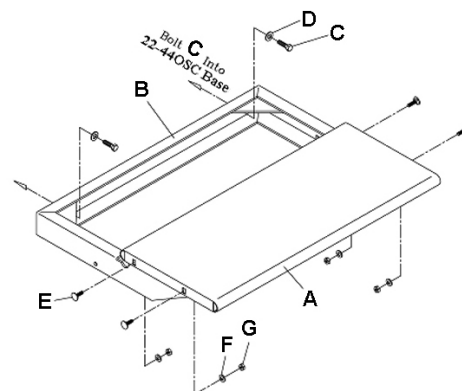

Figure 6

Installing Accessories

Infeed and Outfeed Tables

The infeed and outfeed table is an optional accessory.

1. Bolt the *base bracket* (B, Fig. 6) to the sander base with two 3/8"-16 x 1" hex head cap screws (C) and two 3/8" flat washers (D). Tighten the screws.

2. Mount the table (A) to the base bracket (B) with four 1/4"-20 x 3/4" carriage bolts (E), four 1/4" flat washers (F) and four 1/4" hex nuts (G). **Note:** Leave the carriage bolts loose for now.

3. Place a straight edge on the conveyor bed and extending out over the extension table. Raise or lower the extension table until it is level with, or slightly below, the surface of the conveyor belt. Tighten the hex nuts (G).
4. Repeat for the other table.

Dust Cover

To open the dust cover, push in on the *knob* (A, Fig. 7) and lift. The latch can be adjusted using the screw behind it.

Dust Collection

Dust collection is mandatory for a safe work environment and extended abrasive life. The 22-44OSC is equipped with a 4" dust collection port at the top of the dust cover. It is designed to be used with standard 4" *dust collection hose* (B, Fig. 7) connected to a high volume dust collector (minimum 500 CFM) as shown.

Walter Meier (Manufacturing) Inc., offers a variety of Dust Collectors and Air Filtration Units. Contact your local distributor for more information.

Installing Abrasives

An 80-grit, 3-1/8" wide abrasive strip is already installed on the drum of your sander.

Proper attachment of the abrasive strip to the drum is critical to achieving top performance from your drum sander. Abrasive strips do not have to be pre-measured. The end of the roll is first tapered and attached to the left (outboard) side of the drum. Then the strip is wrapped around the drum, and the second taper is made for attachment to the right (inboard) side of the drum.

Note: You can use the original abrasive strip mounted to the drum as a template for cutting your own strips.

1. Mark and cut a taper at one end of the roll as shown in Figure 8. Because the tapered end should use all of the left (outboard) slot width, its end must be trimmed back as shown.
2. Raise the fastener lever (D, Fig. 9) on the outboard end of drum, and insert the tapered end of the abrasive (E, Fig. 9) so that it uses most of the width of the slot. Release the fastener lever to securely hold the strip end to the fastener.
3. Begin wrapping the strip around the drum. The tapered edge of the strip end should follow the edge of the drum.
4. Continue to wrap the abrasive in a spiral fashion by rotating the drum with one hand and guiding the strip with the other (Figure 10).

Successive windings of the strip should be flush with previous windings *without any overlap*.

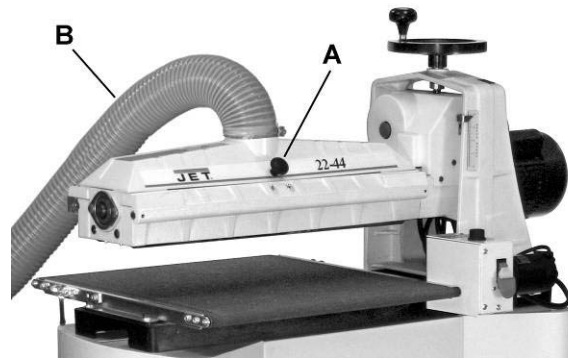

Figure 7

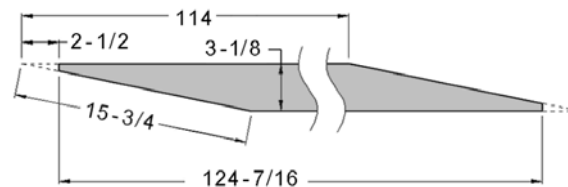

Figure 8

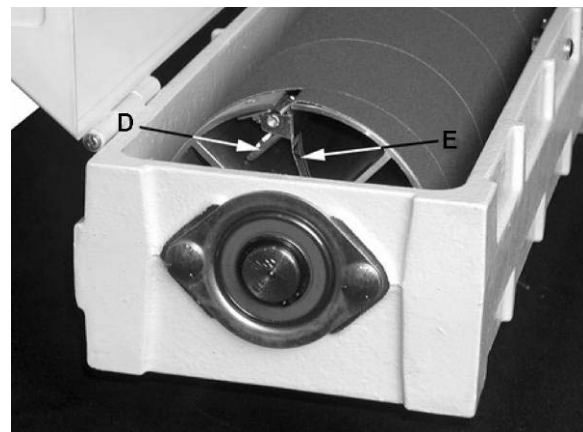

Figure 9

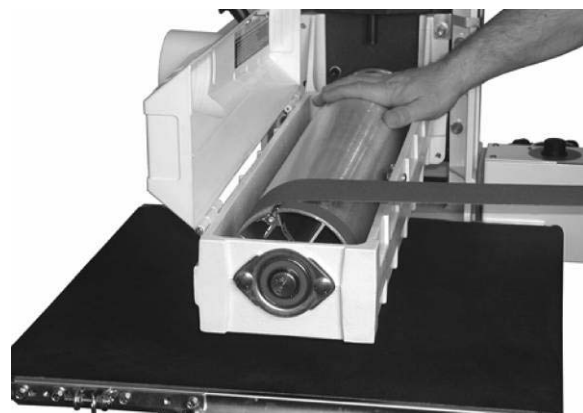

Figure 10

5. Mark the trailing end of the strip where it crosses the right (inboard) end of the drum (Figure 11).
6. Remove the abrasive strip from the drum, and cut a taper as was done with the starting edge (see Figure 8). **Note:** The taper on the remaining roll can be used as the taper for the starting edge of the next strip to be cut.
7. Rewrap the drum beginning at the left, as described in steps 2 through 4.
8. You can use your fingers to work the infeed take-up fastener, but it will be more convenient to use the TUFTool supplied with your sander. Hold the TUFTool with the red end pointing away from you (Figure 12) and insert its hook into the outside hole of the fastener lever (see Figure 14).
9. Lift the lever with the TUFTool, pulling the lever up until it touches the inside of the drum.
10. Turn the TUFTool counterclockwise and lower it onto the abrasive strip, making sure it is holding the paper tight (Figure 13).
11. Insert the tapered end of the abrasive strip into the slot and fastener. It may be necessary to trim the tapered end of the abrasive strip so that it does not “bottom out” against the inside of the drum.

IMPORTANT: Leave a gap – at least 1/8” – between the tapered strip and the closed end of the slot (Figure 13) to allow strip to be pulled into the fastener as needed. If necessary, trim the outside edge of the abrasive strip.

12. Hold the abrasive in place with your left hand, lift up the TUFTool and turn it clockwise while maintaining upward pressure. Slowly move the TUFTool away from you slightly, then down, while easing it out of the hole. This releases the lever in its proper position (Figure 14).

All abrasive strips will stretch in use and may stretch enough to allow the take-up lever to reach its lowest position so that it can not maintain tension on the strip. If this occurs, follow the above procedures to re-set the take-up lever.

Always remove TUFTool from machine before operating.

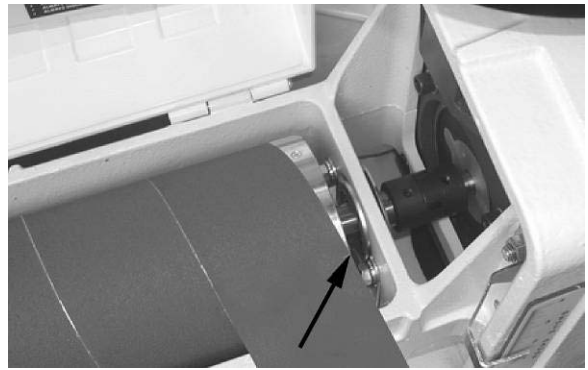

Figure 11

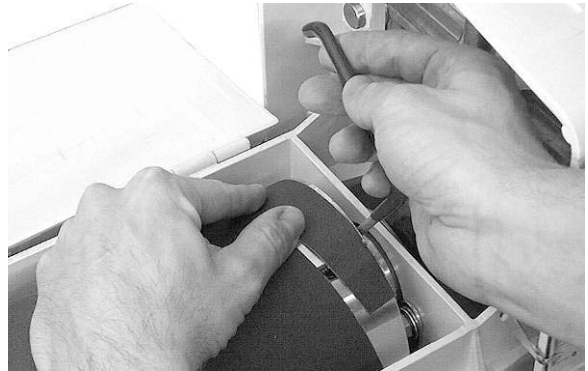

Figure 12

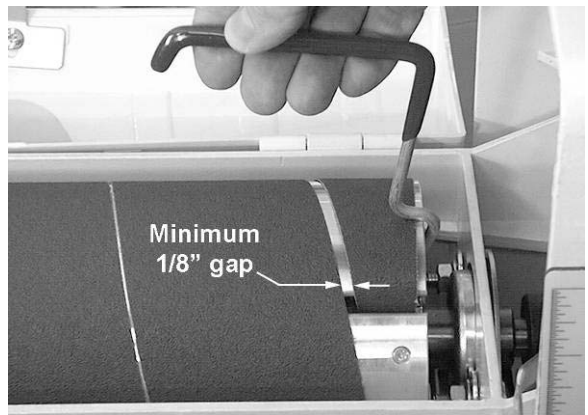

Figure 13

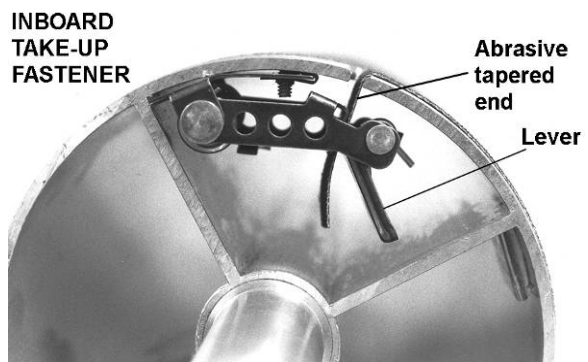

Figure 14

Grounding Instructions

⚠WARNING Electrical connections must be made by a qualified electrician in compliance with all relevant codes. This machine must be properly grounded to help prevent electrical shock and possible fatal injury.

In the event of a malfunction or breakdown, grounding provides a path of least resistance for electric current to reduce the risk of electric shock. This tool is equipped with an electric cord having an equipment-grounding conductor and a grounding plug. The plug must be inserted into a matching outlet that is properly installed and grounded in accordance with all local codes and ordinances.

Do not modify the plug provided. If it will not fit the outlet, have the proper outlet installed by a qualified electrician.

Improper connection of the equipment-grounding conductor can result in a risk of electric shock. The conductor, with insulation having an outer surface that is green with or without yellow stripes, is the equipment-grounding conductor. If repair or replacement of the electric cord or plug is necessary, do not connect the equipment-grounding conductor to a live terminal.

Check with a qualified electrician or service personnel if the grounding instructions are not completely understood, or if in doubt as to whether the tool is properly grounded. Use only three wire extension cords that have three-prong grounding plugs and three-pole receptacles that accept the tool's plug.

Repair or replace a damaged or worn cord immediately.

As received from the factory, your drum sander is intended for use on a 20 amp, 110V dedicated circuit, which has an outlet and a plug that look like the ones illustrated in Figure 15. The sander **cannot** be rewired to voltages other than factory settings.

A temporary adapter, which looks like the adapter illustrated in Figure 16, may be used to connect this plug to a two-pole receptacle, as shown in Figure 16, if a properly grounded outlet is not available. The temporary adapter should only be used until a properly grounded outlet can be installed by a qualified electrician. **This adapter is not applicable in Canada.** The green colored rigid ear, lug, or tab, extending from the adapter, must be connected to a

permanent ground such as a properly grounded outlet box, as shown in Figure 16.

Extension Cords

If an extension cord is necessary, make sure the cord rating is suitable for the amperage listed on the machine's motor plate. An undersize cord will cause a drop in line voltage resulting in loss of power and overheating.

Table 1 shows the correct size cord to use based on cord length and motor plate amp rating. If in doubt, use the next heavier gauge. The smaller the gauge number, the heavier the cord.

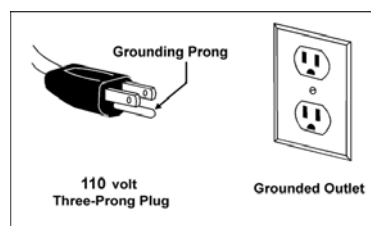

Figure 15

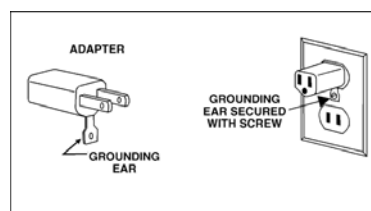

Figure 16

Recommended Gauges (AWG) of Extension Cords

Amps	Extension Cord Length *					
	25 feet	50 feet	75 feet	100 feet	150 feet	200 feet
< 5	16	16	16	14	12	12
5 to 8	16	16	14	12	10	NR
8 to 12	14	14	12	10	NR	NR
12 to 15	12	12	10	10	NR	NR
15 to 20	10	10	10	NR	NR	NR
21 to 30	10	NR	NR	NR	NR	NR

*based on limiting the line voltage drop to 5V at 150% of the rated amperes.

NR: Not Recommended.

Table 1

Operating Controls

On/Off Switch (Sanding Drum)

To start the sander, pull *switch* (A, Fig. 17) out. To stop the sander, push switch in. This switch operates the sanding drum only. The conveyor is controlled separately.

Switch Lockout

For safety and to prevent unauthorized use of the sander, pull out the *key* (B, Fig. 17). Press *switch* (A, Fig. 17) to OFF position before removing the key. When the key is removed, the drum can not be started.

Note: The conveyor belt can still run when the key is removed).

To replace the key, slide it back into the switch until it snaps.

Conveyor

The conveyor speed is controlled by the conveyor *speed rate control knob* (E, Fig. 18) which sets the conveyor speed from stopped (knob fully counterclockwise) to 10fpm (knob fully clockwise).

Drum Height Control

Drum height is controlled by the *height adjustment handwheel*. Rotating the handwheel counterclockwise lowers the drum; clockwise raises it.

One revolution of the handwheel moves the drum approximately 1/16".

Oscillator Switch

Referring to Figure 18:

The 22-44OSC sander can be operated as a simple sander or as an oscillating sander.

When operating as a linear sander, the sander drum rotates as the conveyor slides the workpiece through. When in the oscillating mode, in addition to the operation described, the sander drum head oscillates from left to right as shown in Figure 18.

For linear sanding mode:

1. Sander must be turned off.
2. Pull the *oscillator switch* (A) OUT.

Note: Before pulling the oscillator switch out for linear sanding mode, turn the oscillator switch to manually position the sanding drum to center or where otherwise desired.

3. Turn machine on.

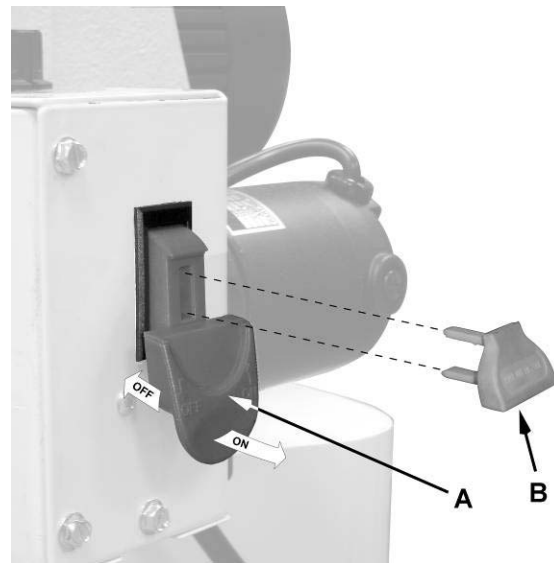

Figure 17

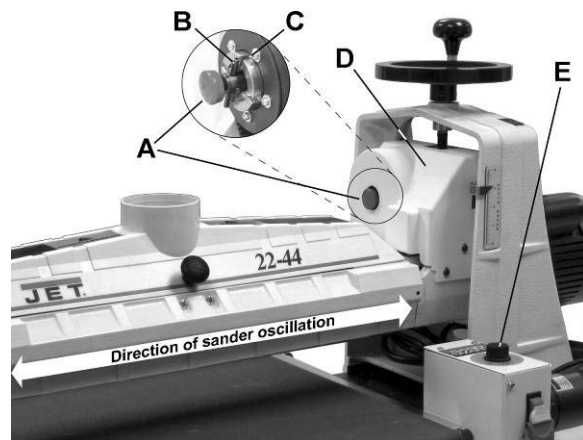

Figure 18

For oscillating sanding mode:

1. Sander must be turned off.
 2. Press *oscillator switch* (A) IN and at the same time rotate the switch (either direction) until the *pins* (B) protruding from the oscillator switch shaft engage in the *detent* (C) of the pulley base.
 3. Turn the *feed rate control knob* (E) fully clockwise.
- Note:** The feed rate must be set to maximum when in the oscillation mode.
4. Turn the machine on.

Adjustments

Depth Gauge

The depth gauge indicates the distance between the bottom of the sanding drum and the top of the conveyor surface. Adjustment is performed by “zeroing” the gauge.

1. Loosen screw (A, Figure 19) sufficiently to allow the pointer (B) to be turned to depth gauge scale.
2. With an abrasive strip on the drum, lower sanding drum to where it touches top of conveyor belt.
3. At this drum position, the depth gauge pointer (B) should align with the zero mark of the scale. If it does not, loosen screw (A) and raise or lower pointer to align with zero on the scale.
4. Re-tighten screw (A).

Note: Depending on the desired accuracy, you may need to repeat this process when installing different abrasive grits.

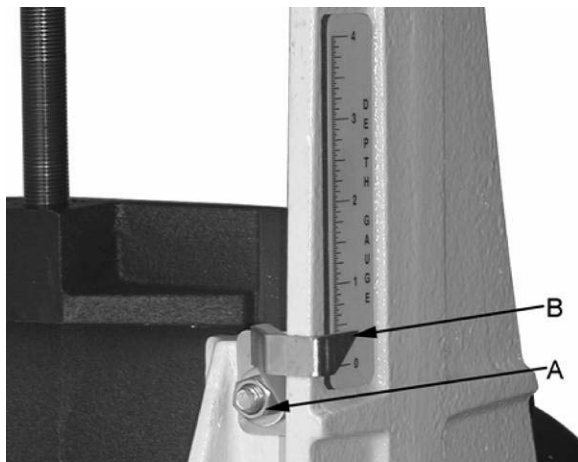

Figure 19

Conveyor Belt Tension and Tracking

Conveyor belt tension adjustment may be necessary during the break-in period to compensate for belt stretching.

IMPORTANT: The conveyor belt has been *overtensioned* for the purpose of shipping. Before operating the sander, adjust the belt tension according to the following instructions!

Tension. To adjust the tension of the conveyor belt, first adjust the take-up screw nut (A, Figure 20) using the attached wrench (B, Figure 20). Do this on both sides of the conveyor to obtain approximately equal tension on both sides of the belt when taut. Insufficient belt tension will cause

slippage of conveyor belt on the drive roller during sanding operation; the conveyor belt is too loose if it can be stopped by hand pressure applied directly to the top of the conveyor belt. Excessive belt tension can result in bent rollers, bent brackets, and/or premature wearing of the bushings or belt.

Tracking. Belt tracking adjustments are made while the conveyor belt is running. After the proper belt tension is obtained (see above), turn the conveyor on and set it at the fastest speed setting. Watch for a tendency of the conveyor belt to drift to one side of the conveyor. To adjust tracking, tighten the take-up screw nut on the side toward which the belt is drifting, and loosen the take-up screw nut on the opposite side an equal amount.

Adjusting the take-up screw nuts on either side of the conveyor allows belt tracking adjustments to be made without affecting belt tension.

Note: Adjust take-up screw nuts only 1/4 turn at a time. Then allow time for the belt to react to the adjustments before proceeding further. Try to avoid over adjustments.

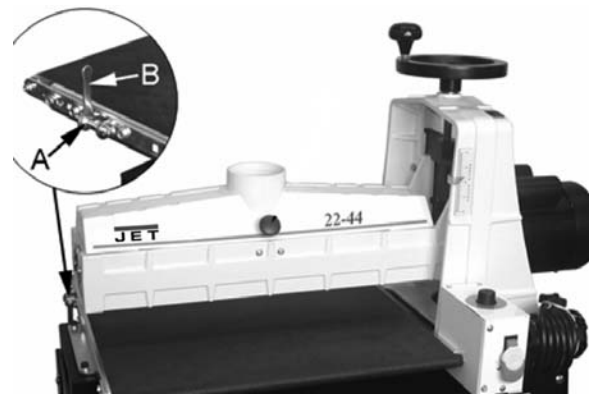

Figure 20

Trackers

The sander comes equipped with “Trackers”, ceramic guides that reduce the amount of adjustments needed to keep the conveyor belt tracked (centered) on the conveyor bed. These guides have a magnetic backing to keep them in place. If a Tracker wears through, it can be reversed by turning it over. The *Tracker Kit* section on Page 22 contains more information about re-setting trackers.

Conveyor Belt Replacement

1. Unplug the machine from the wall receptacle, and unplug the motor cord from the control box receptacle.
2. Raise drum to its highest position using the handwheel.
3. Loosen the conveyor take-up screw nuts (A, Fig. 20) to relieve belt tension, and slide the driven roller fully inward.
4. Remove the four bolts that attach the conveyor table to the base. Lift up the conveyor table and remove it from machine. Avoid tearing the belt on any edges underneath the conveyor bed.
5. Install new belt, and re-install conveyor table. Take care not to damage the Trackers. Tension and track the new belt.

Note: If the conveyor belt continually tracks to one side of the machine, reversing the belt on the conveyor bed may remedy the problem. To make sure the conveyor bed is not twisted, place a level on the conveyor bed. Level the machine if needed. If there is still a problem, proceed with the steps below:

Step 1: Check the conveyor drive roller and the driven roller to make sure they are parallel to the surface of the conveyor bed. To do this, first center the conveyor belt on the bed. Then lay a straight-edge on the exposed edge of the conveyor bed on the left (outboard) side, extending it over the roller. Note the distance between the roller and the straightedge.

Step 2: Now repeat Step 1 on the right (inboard) side of conveyor. Compare the measurements from side to side. If they are not equal, loosen one of the brackets that hold the roller in place. Tip this bracket until the distance between the roller and the straight-edge are equal from side to side, then tighten the bracket.

Checking Drum Alignment

The sanding drum must be aligned parallel to the conveyor bed for proper machine operation. The sanding drum comes preset from the factory. If a problem with the drum alignment occurs, follow the instructions below.

First inspect the alignment with a gauge of some kind. The following procedure uses a steel straight edge as a gauge.

1. Unplug sander from power source.
2. Open the dust cover and remove the abrasive strip from the drum.

3. Insert gauge between the drum and conveyor bed at the outer end of the drum (Figure 21).

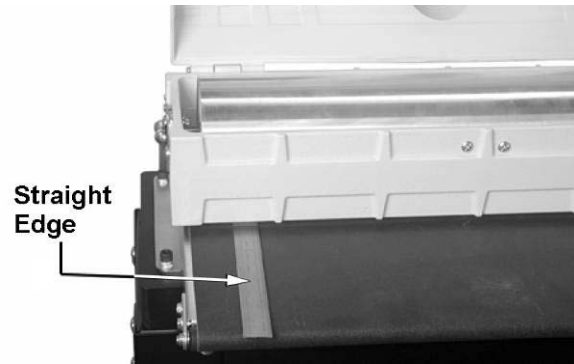

Figure 21

With the dust cover open, lower sanding drum while slowly rotating drum by hand until the drum lightly contacts the thickness gauge.

4. Remove thickness gauge and place under drum at the other end.
5. If the drum does not contact the thickness gauge to the same degree as the opposite end of the drum, alignment is necessary.

To align the drum:

6. Loosen the four 3/8" hex cap screws – two front, two rear (A, Fig. 22). This allows the entire drum carriage and shroud to be pivoted on two screws – one screw in front, one in back.
7. Lay the thickness gauge under the drum lengthwise. See Figure 23. Rotate the fine tune adjustment knob (B, Fig. 22) until the drum contacts the gauge equally along its entire surface. Rotate the knob clockwise to raise the outboard end of the drum, counterclockwise to lower the outboard end of the drum. Use the height adjustment handwheel to raise or lower the entire drum.
8. When drum is parallel to conveyor, tighten the four screws (A, Fig. 22).

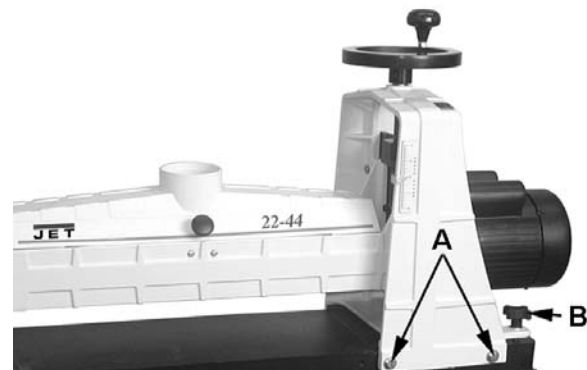

Conveyor table removed for clarity

Figure 22

Fine Tuning Drum Alignment

Note: This is an operational test. Perform this alignment after you have become familiar with sander operation.

When sanding boards wider than the drum, drum alignment is critical and must be adjusted exactly level to slightly higher on the outboard end. This will prevent any ridges from developing in the stock. Always check this on a piece of scrap wood, as follows, before sanding the work piece.

1. Run a piece of scrap wood approximately 6" wide by 30" to 40" long through the sander sideways so that the end of the board extends past the end of the drum.
2. Without changing drum height, rotate the board 180° and sand the same side.
3. If a ridge is visible where the drum overlaps, loosen the four screws (A, Fig. 22) and raise the outboard end of the drum by turning the fine tune adjustment knob (B, Figure 22) slightly clockwise.

Important: Only turn fine tune adjustment knob when all four screws (A, Fig. 22) are loose.

4. Repeat this process until the ridge is eliminated and the entire board is sanded.
5. Tighten the four screws (A, Fig. 23).

Note: Keep track of how many revolutions of the fine tune knob are needed to change drum alignment for wider (over 22") sanding. When sanding narrow stock (less than 22") loosen the four screws (Figure 22) and turn fine tune adjustment knob counterclockwise the same amount as the initial wide sanding so that drum is again parallel.

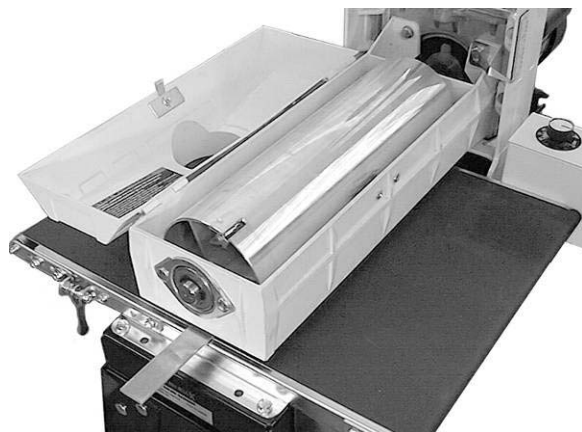

Figure 23

Tension Roller Alignment

The infeed and outfeed rollers are tensioned to provide downward pressure on the workpiece to prevent slippage on the feed conveyor. Tension rollers are set at the factory, but should be inspected and may require adjustment as the sander receives use.

WARNING Improperly adjusted tension rollers (i.e. those set too high, rendering them non-functional) could allow kick-back of pieces being sanded.

1. Unplug sander from power source and remove abrasive (D, Figure 24) from drum.
2. Loosen all four hex nuts on the bearing bolts (E, Figure 24). This will allow both tension rollers to drop to their lowest position. (NOTE: Figure 24 only shows outboard end of drum. Adjustments must be made on *both ends* of drum.)
3. Lower sanding drum to where it just contacts the conveyor bed. Then raise the sanding drum by making 3/4 turn of the height adjustment handle.
4. Tighten the four hex nuts (E, Figure 24). Both tension rollers are now positioned about 1/16" below the bottom of the sanding drum.

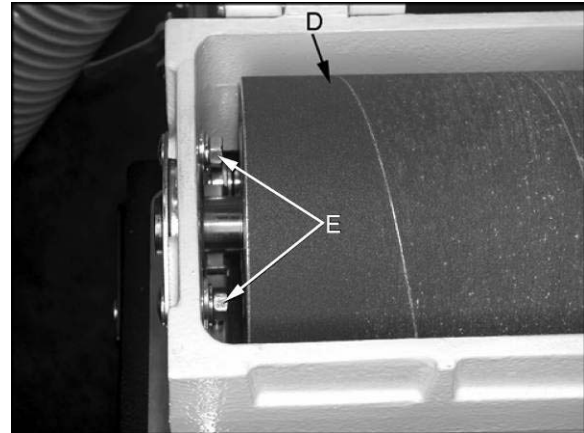
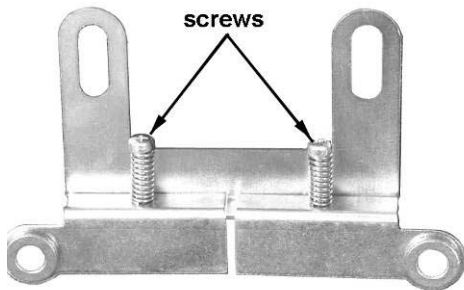

Figure 24

Tension Roller Pressure Adjustment

You can increase or decrease tension roller pressure by turning the screws on the tension roller brackets (Figure 25).



Tension Roller Bracket

Figure 25

Too much tension roller pressure can result in a “snipe” mark, which is identified as a visible line running across the width of the board and located approximately 2-1/4” from the end of the board.

If the snipe occurs on the leading end of the board, adjust the outfeed tension roller. If the snipe occurs on the trailing end of the board, adjust the infeed tension roller.

Tension roller pressure can also be adjusted by raising the height of the rollers, as follows:

1. Repeat “Tension Roller Alignment” except raise the sanding drum only 1/4 turn of the height adjustment handle.
2. If both tension rollers are causing snipe then tighten all four hex nuts (E, Fig. 24) at this position.
3. If only outfeed tension roller causes snipe, only tighten rear (outfeed) hex nuts on each end of drum at this position, then raise sanding drum another 3/4 turn of the handle.
4. Press infeed tension roller down to rest on conveyor bed and tighten front (infeed) hex nuts at this position.

This process sets the tension roller assembly at an angle providing less tension pressure on the outfeed roller.

Drum Height Control Adjustment

If the height control mechanism does not operate easily or smoothly or there is excessive vertical movement or deflection of the drum carriage, perform the following adjustments.

1. Tighten all four lock nuts (A, Fig. 26) and then loosen them 1/8 to 1/4 turn. If the lock nuts are set too tight, height control will not operate easily. If the lock nuts are too loose, excessive deflection of the outboard end of the drum carriage will result.
2. Thoroughly lubricate the mating surfaces of the motor mount slide (B, Fig. 26), and the height adjustment screw (C, Fig. 26).

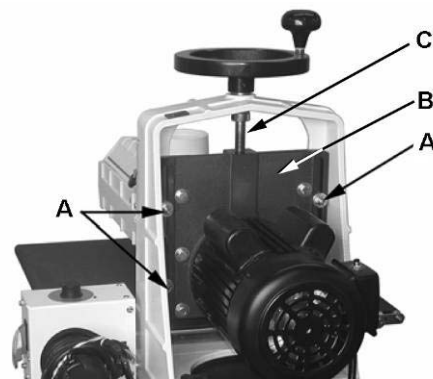

Figure 26

Operation

Before using your drum sander, review the previous pages in this manual on initial set-up and adjustment. In this section, you will learn how to operate the machine. Make sure an abrasive strip is mounted and a proper dust collection system is connected.

Basic Operating Procedure

1. Set depth of cut.
2. Start dust collection system.
3. Select linear or oscillating sanding mode.
4. Start drum.
5. Start conveyor and select feed rate. If oscillator is engaged, set feed rate to maximum speed.
6. Feed stock through machine.

To feed stock through the sander, rest and hold the board to be sanded on the conveyor belt, allowing the conveyor belt to carry the board into the drum. Once the stock is halfway through, reposition yourself to the outfeed side of the machine to receive and control the board as it exits.

Setting Depth of Cut

Adjusting the drum sander for the proper contact between the abrasive and the stock determines the depth of cut. The depth of cut is controlled by the height adjustment handwheel.

It may take some experimentation to determine the proper depth of cut, given the variables of abrasive grit, type of wood, and feed rate. For best results, use scrap wood to practice sanding and to develop skill and familiarity with the machine before doing finish work.

A combination of several variables will determine the proper depth of cut to use, including the following:

1. Abrasive type and grit size.
2. Width of the piece being processed.
3. Hardness of the piece.
4. Feed rate of the conveyor belt.

Establishing Proper Drum Height

A good rule of thumb when sanding with grits finer than 80 is to place the stock to be sanded under the drum and lower drum until it contacts the stock. Drum should still rotate by hand. **Without changing drum height**, finish feeding the stock under the sander.

Start sanding drum and sand the stock at that same position.

⚠ WARNING Do not start drum while in contact with stock!

For sanding with grits coarser than 80, you can raise the conveyor table slightly.

Always maintain control of stock. Through practice you will learn the proper depth of cut considering the variables above.

Selecting SandSmart™ Feed Rates

A faster feed rate allows faster sanding but fewer revolutions of the drum per inch of sanding. A slower feed rate provides more revolutions of the drum per inch of sanding to allow a greater depth of cut and smooth sanding.

Note: If sanding with the oscillator engaged, the feed rate must be set to maximum speed.

Begin experimenting with the feed rate set at about 40% to 50% of maximum. The best feed rate will depend on a number of factors, including type of stock, grit and depth of cut used, and whether the stock is fed directly in line with the conveyor bed or at an angle. If the drum motor is lugging down, if the conveyor belt is slipping, or if you observe a ripple effect on the stock, slow down the feed rate. If the finish is smooth and the machine is not overworking, you can experiment using a faster feed rate.

The SandSmart control continuously monitors the load on the drum motor, and automatically regulates the speed of the conveyor motor to maintain the highest feed rate without overload. If the load on the drum motor increases, the SandSmart control will decrease the conveyor feed rate and will stop the conveyor under extreme conditions. If the load on the drum decreases, SandSmart will increase the feed rate but will not increase it faster than the manual setting on the speed adjustment label.

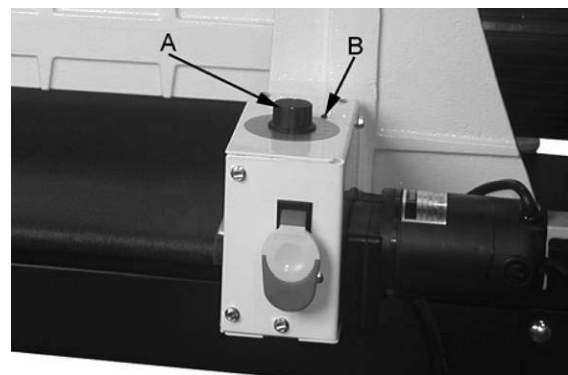

Figure 27

The best and most consistent finish will be achieved if the conveyor does not change speed during operation. When the *red indicator light* (B, Fig. 27) comes on, the SandSmart control

has detected too great a depth of cut and/or too fast a feed rate.

This change in conveyor speed may affect the finish surface. If the finish is affected, make another sanding pass without changing any settings. If the finish is still affected, make adjustments by slowing the conveyor and/or decreasing the depth of cut and run the stock through again.

Also try a faster feed rate or less depth of cut if the stock you are working begins to show burn marks. With cherry, hard maple or other hardwoods, using a shallower depth of cut and a faster feed rate will help minimize burn marks. Slightly angling the stock as it is fed into the machine will also help prevent burning the stock.

Because of the wide range of variables, it is important to experiment with your specific conditions and make adjustments to achieve the optimum feed rate. If problems occur, first check and adjust the feed rate, referring to the "Troubleshooting" sections in this manual.

Tips for Maximum Performance

The versatility designed into the 22-44OSC drum sander allows it to be used for a wide variety of tasks that will boost the return on your investment. For example, its capabilities range from taking the place of a planer to thickness rough stock, to speeding up fine sanding work often done with slower, dust-generating hand sanders.

Learning how to use its adjustments and controls will allow you to fine-tune the machine for maximum results. The best results come from experimenting with different abrasive grits and machine adjustments to fit the job at hand. Following is a list of useful tips which can help you improve performance of your sander.

Dust Collection

When connecting dust collectors, remember that straight pipe will not restrict airflow as much as flexible tubing. Y's and elbows will restrict airflow less than T's. Also, a hose smaller than 2-1/2" diameter should not be used.

Multiple-Piece Sanding Runs

When abrasive planing (or thickness sanding) a run of similar pieces that you want to have the same thickness, it is best to determine the thickness of the thinnest piece and process all pieces to that same thickness in one session. Be aware that the sander will remove cups and crowns in the workpiece; consider this when measuring and processing stock to the same thickness.

Sanding Multiple Pieces At Once

When sanding multiple pieces simultaneously, make sure to stagger (step) the pieces across the width of the conveyor belt. This provides better contact with the tension rollers. Try to process only multiple pieces of similar thickness.

If there is a significant thickness difference, the thinner pieces can slip on the conveyor belt if they do not contact the tension rollers. Also note that pieces thicker than 3/4" should be longer than the minimum normally recommended to prevent tipping of the stock.

Edge Sanding

When edge sanding, the sander will mimic the opposite edge of the stock which is lying on the conveyor belt. Because of this, it is important for the stock edge to have been ripped at the proper angle to the face before the sanding process. When edge sanding stock that is less than 3/4" wide or more than 2" high, it is good procedure to stack and clamp several pieces together to prevent them from slipping or tipping on the conveyor belt.

Sanding Imperfect Stock

When sanding stock with a cup or crown, place the crown up. This will stabilize the stock to help prevent tipping or rocking during sanding. After the crown has been removed and the top is flat, turn the stock over and sand the opposite side. To avoid personal injury, take special care when sanding stock that is twisted, bowed, or otherwise varies in thickness from end to end. If possible, support such stock as it is being sanded to keep it from slipping or tipping. Use extra roller stands, help from another person, or hand pressure on the stock, to minimize potentially hazardous situations.

Face Frames and Raised Panel Doors

It is very important to have the proper abrasive contact when doing this type of sanding. If the machine is set to take an excessive depth of cut, the result can be a gouge or dip as the drum goes from sanding the rails at full width to sanding just a few inches of width on the stiles. To prevent this make sure, when using abrasives finer than 80 grit, that the drum is in contact with the wood but can still be spun by hand. If there is room, angling the stock on the conveyor belt can also help. Slowing the conveyor feed when coming to a rail in the stock can help prevent a dip or gouge. This allows the abrasive to work the wider width with less effort, and to achieve better consistency of the finished surface.

Stock Feeding Angle

Some pieces, because of their dimensions, will need to be fed into the machine at a 90° angle (perpendicular to the drum). However, even a slight offset angle of the stock will provide for more effective stock removal. The optimum feeding angle for stock removal is about 60°.

Angling the workpiece for stock removal provides other advantages, such as less loading of certain areas of the drums due to glue lines or mineral streaks in the stock, more even wear of abrasive strips, potentially faster feed rates, and lighter loads on the motor. Note that to get the best final finish, however, the stock should be fed through the machine so it will be sanded in line with the grain of the wood on the final one or two passes.

Maintenance

⚠WARNING Before doing maintenance on the machine, disconnect it from the electrical supply by pulling out the plug or switching off the main switch! Failure to comply may cause serious injury.

Keeping the Machine Clean

For best results, make cleaning the sander a regular shop procedure. Allowing excess build-up of dust and debris can adversely affect performance through the loading of the abrasives, slippage on the conveyor table, and/or the accumulation of material inside the drums which can throw off the center of balance.

Leave the dust collector on when cleaning dust from the drums. Also brush the conveyor belt after cleaning operations. If not cleaned, the conveyor belt could allow stock to slip during sanding operations.

For best results, perform the following recommended procedures on a **monthly** basis:

- Lubricate conveyor bushings and check for wear.
- Lubricate all moving parts, such as threaded rods, washers, and bushings. (Bearings are pre-sealed and require no lubrication.)
- Clean sawdust from the abrasive strip and brush dust from the conveyor belt.
- Keep oscillation roller and gib areas clean.
- Blow dust from motors and switches. Blow dust from inside of sanding drum, which may cause vibration or offset the center of balance.
- Check all set screws for tightness on parts such as bearings, the conveyor, and couplings.

Tracker Kit

Stock No.: 98-0080A

Trackers dramatically reduce tracking adjustments of conveyor belts. They are already installed on your sander. The following information is for re-setting or replacing your trackers, should that become necessary. Refer to Figure 28.

1. Disconnect power to sander, and disconnect motor cord from control box receptacle.
2. Lower conveyor table as far as it will go.
3. Loosen the conveyor take-up screw nuts to relieve conveyor belt tension and slide driven roller fully inward. Slide conveyor belt to one side of bed.
4. Remove the four bolts holding the conveyor table to the sander base.
5. Lift conveyor table and slide it out of the sander. Turn conveyor table upside down. Be careful not to damage the conveyor belt.
6. On the underside of the conveyor bed, there are U-channels welded to the bed. The Tracker is positioned on the inside of the first U-channel on the infeed side of sander (the U-channel closest to the rubber covered drive roller and gear motor). The back of the Tracker is magnetized and will stick to the side wall of the conveyor bed. Do not install Tracker if the edge of the conveyor belt is damaged or torn.
7. With the first Tracker installed, slide the conveyor belt into the bottom slot of the Tracker. **Note:** When installed properly, only the bottom lip of the Tracker will be visible.
8. Install second Tracker opposite the first. Use both Trackers unless the second one does not fit in conveyor or if conveyor belt is damaged.
9. Turn conveyor table right-side up and reposition it onto the sander. Re-attach the four mounting bolts and tighten. **Caution:** Be careful not to knock Tracker(s) out of conveyor bed when turning conveyor over.
10. Make sure all switches are off. Connect power to sander and plug in motor.
11. Tension the conveyor belt using take-up screw nuts. If both Trackers are installed, it is very important to have equal tension on both sides of the conveyor belt. Tighten both sides of take-up screw nuts until equal tension is obtained.
12. To check tension, turn on conveyor full speed and place both hands on conveyor. If conveyor belt can be stopped, continue tensioning until conveyor belt cannot be stopped by both hands on the belt while the conveyor is operating at full speed.
13. Make sure conveyor belt runs smoothly inside Tracker slot and that the magnet is holding the Tracker in position.
14. Continue to watch tracking of conveyor and adjust only if necessary, making sure to keep equal tension on conveyor belt at all times and not allowing conveyor belt to buckle under conveyor bed.

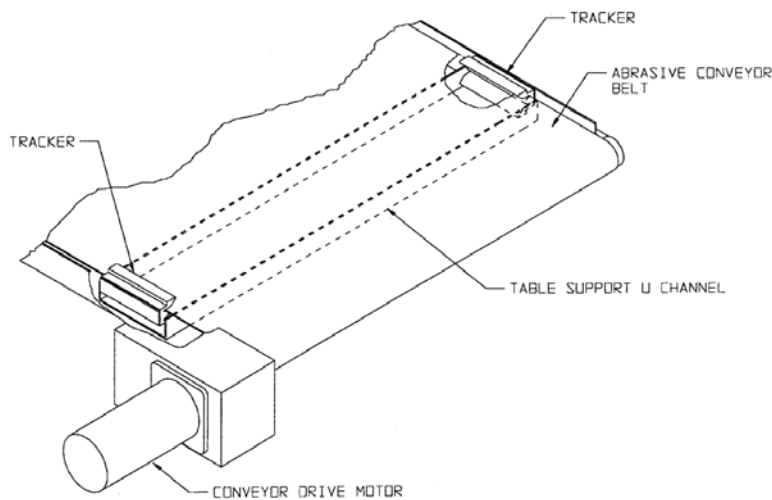

Figure 28 – Underside of conveyor shown

Abrasives

The abrasive material you choose will have a substantial effect on the performance of your sander. Variations in paper type, weight, coating and durability all contribute to achieving your desired finish.

Selecting Drum Abrasives

It is important to select the proper grit of abrasive for the type of sanding being performed to achieve maximum results. As with any sanding operation, first begin sanding with a coarser grit, depending upon the roughness of the stock or the amount of stock to be removed. Then progressively work toward finer grits. The chart below shows the general uses for the various grits.

The amount of stock to be removed is a major consideration when choosing the grit grade with which to begin. Grits 24, 36, 50 and 60 are primarily designed for stock removal. Grits 24 and 36 will remove the most material in one pass, whether you are doing abrasive planing, cleaning up glued panels, or flattening stock. Grits from 100 through 220 are primarily finishing grits designed to remove the scratch pattern from the previous grit used. For best results, never skip more than one grit grade when progressing through a sanding sequence.

For fine work, such as furniture, try not to skip any grit grades during the sanding process.

In general, premium quality abrasives will produce a better finish with a less noticeable scratch pattern.

Note: Grits that are too fine can sometimes burnish the wood and leave a glossy surface which will not accept stains evenly. This will vary by type of wood. Oak, for example, is

susceptible to burnishing because of its open pores.

Cleaning Abrasive Strips

Regularly clean the abrasive strips on the drums with commercially available cleaning sticks, following the manufacturer's directions. When cleaning, also brush the stick crumbs from the drum while it is still rotating.

In some cases, build-ups resulting from burns can also be removed with Plexiglas held on edge over the rotating drum.

CAUTION Always wear eye protection while performing sandpaper cleaning, and take all precautions to avoid any contact of hands or clothing with the rotating drum.

Cloth-backed abrasives can be cleaned by soaking in paint thinner or mineral spirits for 20 minutes to one hour, then using a brush to remove any build-up. Dry the abrasive strips completely before using. Any used solvents should be discarded in compliance with environmental regulations.

Increasing Abrasive Life

Abrasive life can be increased not only by cleaning, but by removing the abrasive strip from the drum and reversing it. To do this, remove the strip and use what was the trailing end as the starting end on the left (outboard) side of the drum. Reversing the strip will provide a fresh set of cutting edges on the abrasive.

Abrasive Selection Guide

Grit Common Application

- 24Abrasive planing, surfacing rough-sawn boards, maximum stock removal, glue removal.
- 36Abrasive planing, surfacing rough-sawn boards, maximum stock removal, glue removal.
- 50Surfacing and dimensioning boards, truing warped boards
- 60Surfacing and dimensioning boards, truing warped boards.
- 80Light dimensioning, removal of planer ripples.
- 100Light surfacing, removal of planer ripples.
- 120Light surfacing, minimal stock removal.
- 150Finish sanding, minimal stock removal.
- 180Finish sanding only, not for stock removal.
- 220Finish sanding only, not for stock removal.

Optional Accessories

98-2202 Infeed/Outfeed Tables

Troubleshooting

Troubleshooting – Motor and Electrical Problems

Trouble	Probable Cause	Remedy
Sander will not start.	No incoming power.	Check plug connections. Connect main cord to power source, and motor cord into control box receptacle.
	Circuit fuse blown or breaker tripped.	Replace fuse or re-set breaker.
	Switch is malfunctioning.	Replace switch.
Drum motor overloads.	Inadequate circuit.	Check electrical requirements.
	Feed rate too fast or depth of cut too large.	Reduce feed rate and/or depth of cut.
Conveyor motor oscillates.	Motor not properly aligned.	Loosen housing bolts, run motor, re-tighten bolts.
	Transfer rod collar is worn.	Replace transfer rod collar.
	Drive roller bent.	Replace drive roller.
Drum motor or conveyor motor stalls.	Excessive depth of cut.	Reduce depth of cut; use coarser grit; reduce feed rate.
	Improper conveyor belt tension.	Adjust tension (see page 15).
Motor overload protector trips or shop wiring breaker trips.	Excessive load on sanding drum and motor.	Allow motor to cool and re-set overload button.
	Too many tools on circuit.	Connect sander to a dedicated circuit. Have a certified electrician correct any shop wiring problem.
	Excessive length or inadequate size extension cord.	Use a shorter or heavier gauge extension cord (see Table 1).

Troubleshooting – Mechanical Problems

Trouble	Probable Cause	Remedy
Conveyor belt does not move, or runs intermittently.	Shaft coupling (#11, page 38) is loose or unattached.	Align the shaft flats of the gear motor and the drive roller and tighten the shaft-coupling setscrews.
Conveyor belt slips on drive roller.	Improper conveyor belt tension.	Adjust belt tension.
	Excessive depth of cut or feed rate.	Reduce depth of cut; reduce feed rate.
Board slips on conveyor belt.	Tension rollers too high.	Lower tension rollers (see page 17).
	Excessive feed rate.	Reduce feed rate.
	Dirty or worn conveyor belt.	Replace conveyor belt.
	Abrasive improperly wrapped.	See <i>Installing Abrasives</i> .
Conveyor belt tracks to one side, or oscillates from side to side.	Conveyor belt out of adjustment.	Readjust conveyor belt; see page 16.
	Drive or driven roller needs adjusting.	Readjust; see page 16.
	Conveyor belt worn or defective.	Replace conveyor belt; see <i>Conveyor Belt Replacement</i> .
	Drive roller worn, bent, or varies in diameter side to side.	Replace drive roller.
	Roller bushings elongated due to excessive wear.	Replace bushings.
Abrasive strip is loose.	Strip caught on inside edge of slot, or on inboard side of drum.	Re-adjust the strip end in the slot and/or trim the abrasive edge.
	Strip not cut properly.	Re-cut and re-install abrasive strip. See <i>Installing Abrasives</i> .
Abrasive loads up prematurely.	Excessive depth of cut.	Reduce depth of cut.
	Excessive feed rate.	Reduce feed rate.
	Inadequate dust collection.	Increase airflow at dust port.
	Inadequate abrasive.	Use an open-coat abrasive.
	Stock fed at 90° angle to drum.	Angle stock 60° if possible to avoid resin line buildup.
Table height adjustment works improperly.	Improper adjustment of height control.	Readjust height control. See <i>Drum Height Control</i> .
Drum drive v-belt slips.	Improper v-belt tension.	Increase tension.
Knocking sound while running.	Bearing(s) out of alignment.	Re-align bearings.
	V-belt worn.	Replace v-belt.
	Dust in drum.	Remove material inside drum.
	Pulley wobbling or out of round.	Replace pulley.
	Set-screws loose in pulley or bearing.	Re-tighten set-screws.
	Abrasive fastener on drum loose (without abrasive strip in place).	Insert abrasive strip, or replace fastener.
	Drum bearing(s) worn.	Replace drum bearing(s).

Troubleshooting – Operational Problems

Trouble	Probable Cause	Remedy
Ripples in sanded surface. (Non-uniformly spaced ripples).	Uneven feed rate.	Check for these conditions and refer to previous Troubleshooting sections: - Conveyor belt slips on drive roller. - Board slips on conveyor belt. - Conveyor gear motor stalls. - Excessive v-belt tension. - Set-screw loose on shaft coupler between gear motor and conveyor. - Conveyor bushings worn – replace. - Conveyor bushings dry – lubricate.
Ripples in sanded surface. (Uniformly spaced ripples).	Excessive feed rate.	Reduce depth of cut and/or feed rate.
	Excessive depth of cut.	Reduce depth of cut and/or feed rate.
Sniping of wood (gouging near end of board).	Sander vibration.	Check for these conditions: - Loose bolts, or loose bearing and pulley set-screws – re-tighten. - Dirty drum – clean inside. - Excessive v-belt tension – reduce tension. - Worn v-belt – replace. - Warped drive pulley – replace. - Drum out of balance – contact your dealer or Walter Meier authorized service center.
	Tension rollers set too low.	Re-set tension rollers; see <i>Tension Roller Adjustment</i> .
	Stock not supported properly during infeed or outfeed.	Support stock with roller stand, tables or benches.
Burning of wood.	Conveyor drive roller or driven roller higher than conveyor belt surface.	Re-adjust roller(s).
	Feed rate too slow.	Increase feed rate.
	Excessive depth of cut for grit used.	Reduce depth of cut or increase grit coarseness.
	Excess build-up on abrasive strips.	Reduce depth of cut; clean strips or replace; angle stock when feeding.
	Abrasive is too fine.	Replace with abrasive of coarser grit.
	Abrasive strips are overlapped.	Rewrap strip without overlap. See pages 11-12.
Gouging of wood.	Drum out of alignment.	Re-align drum. See pages 16-17.
	Conveyor belt is loose.	Adjust conveyor belt tension. See page 15.
	Excessive depth of cut.	Reduce depth of cut.
	Wood slipping on conveyor due to lack of contact.	Use alternate feeding procedure.
Line or groove in stock.	Abrasive is too fine.	Replace with coarser grit.
Lines or groove in stock while in oscillation mode	Inconsistent feed rate.	Do not stop or change the feed rate while feeding stock.
Unsanded ridge along length of piece (sandpaper appears clean).	Feed rate not set to maximum.	Set feed rate to maximum.
	Grit has been removed from backing.	Avoid this area of drum, or replace abrasive strip.

Replacement Parts

Replacement parts are listed on the following pages. To order parts or reach our service department, call 1-800-274-6848, Monday through Friday (see our website for business hours, www.waltermeier.com). Having the Model Number and Serial Number of your machine available when you call will allow us to serve you quickly and accurately.

Drum Head Assembly – Exploded View

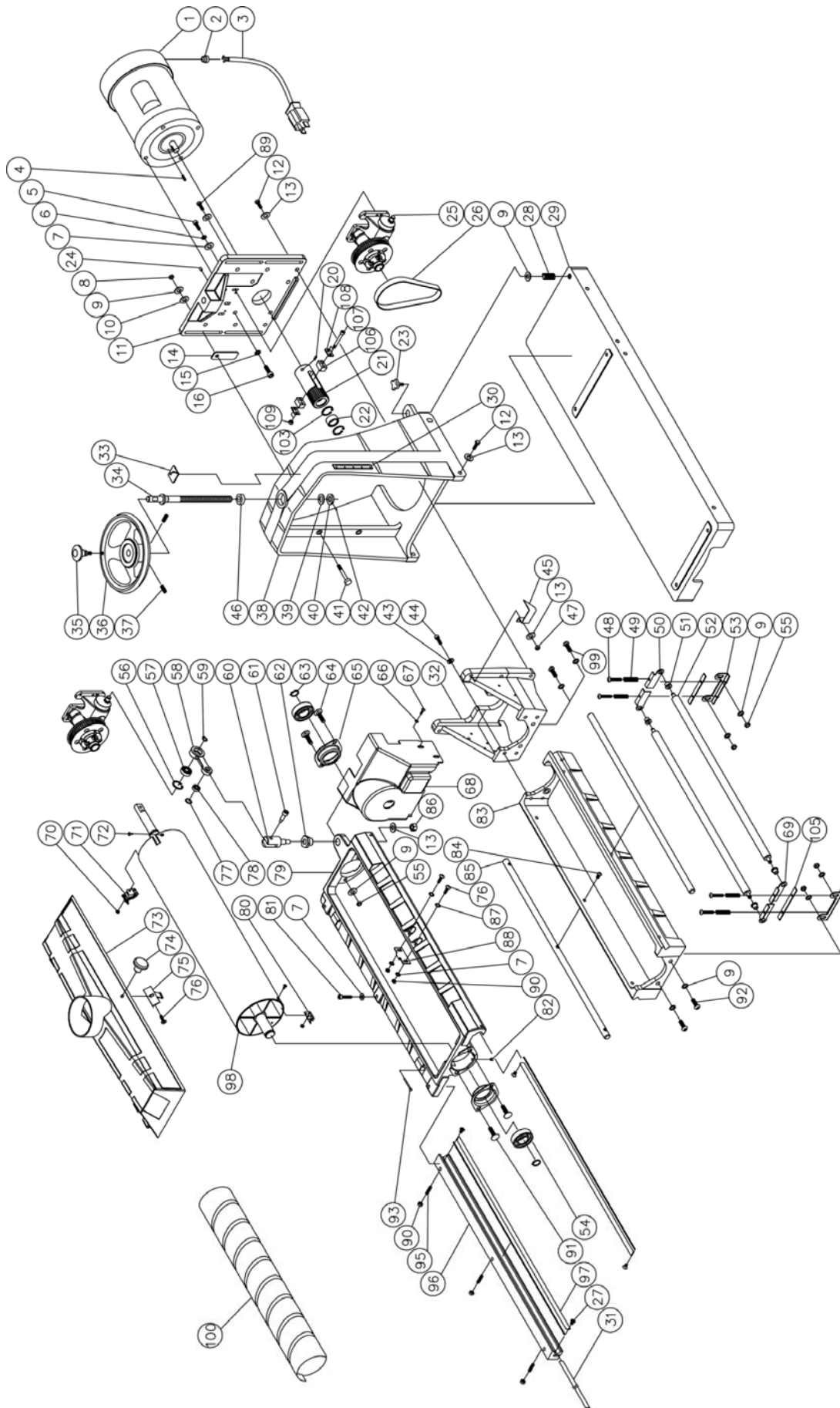

Drum Head Assembly – Parts List

Index No.	Part No.	Description	Size	Qty
1	70-4102	Motor	1-3/4HP, 115V	1
	70-4102MF	Motor Fan (not shown)		1
	70-4102MFC	Motor Fan Cover (not shown)		1
	70-4102CS	Centrifugal Switch (not shown)		1
	70-4102SC	Starting Capacitor (not shown)	125VAC, 300MFD	1
	70-4102RC	Running Capacitor (not shown)	250VAC, 40 μ F	1
	70-4102SCC	Starting Capacitor Cover (not shown)		1
	70-4102RCC	Running Capacitor Cover (not shown)		1
	70-4102JB	Junction Box (not shown)		1
	70-4102JBC	Junction Box Cover (not shown)		1
2	72-6104	Strain Relief		1
3	72-5345	Cord, Motor to Control Box		1
4	20-0762-02	Key	3/16x3/16x3/4	1
5	TS-0207061	Socket Head Cap Screw	1/4-20x1	6
6	TS-0720071	Lock Washer	1/4	6
7	TS-0680021	Flat Washer	1/4	6
8	TS-0640082	Nylon Insert Lock Nut	5/16-24	4
9	TS-0680031	Flat Washer	5/16	4
10	50-3090-01	Oilite Washer		4
11	2244OSC-111	Motor Plate		1
12	TS-0060061	Hex Cap Screw	3/8-16x1-1/4	5
13	TS-0680041	Flat Washer	3/8	7
14	2244OSC-114	Oilite Plate		4
15	TS-0720091	Lock Washer	3/8	4
16	TS-0209061	Socket Head Cap Screw	3/8-16x1-1/4	4
20	TS-0270031	Set Screw	5/16-18x3/8	4
21	2244OSC-121B	Coupler (<i>serial # 11121604 and higher</i>)		1
22	2244OSC-122	Needle Bearing		1
23	80-3138	Fine Tune Adjustment Knob		1
24	2244OSC-124	Set Screw	#10-24x3/8	4
25	2244OSC-GBA	Gearbox Assembly		1
26	2244OSC-126	Timing Belt		1
27	TS-081F021	Flat Head Machine Screw	1/4-20x3/8	4
28	20-3216	Spring		1
29	2244OSC-129	Base		1
30	94-2270	Label, Depth Gauge	4"	1
31	2244OSC-131	Gib		1
32	2244OSC-132	Drum Carriage Head		1
33	94-1668	Height Direction Label		1
34	30-9027	Height Adjustment Screw		1
35	80-3131	Knob		1
36	30-9028	Height Adjustment Handwheel		1
37	TS-0270051	Set Screw	5/16-18x1/2	2
38	30-9023	Shroud		1
39	80-2324	Washer, Flat-Nylon	5/8" I.D.	1
40	20-1180-02	Collar, Locking Shaft		1
41	30-9026	Stud	5/16-24x1-3/4	4
42	TS-0270011	Set Screw	5/16-18x1/4	2
43	TS-0720081	Lock Washer	5/16	4
44	TS-0208061	Socket Head Cap Screw	5/16-18x1	4
45	40-3169	Depth Gauge Pointer		1
46	50-9000	Thrust Bearing	51103	1
47	TS-0561031	Hex Nut	3/8-16	1
48	10-4008-16	Screw, Fillister Head-Phillips	#8-32x1	4
49	20-3211	Spring, Tension Roller		4
50	2244OSC-150	Bracket, Right Tension Roller		2
51	50-3105	Bushing, Oilite	5/16" I.D.	4
52	2244OSC-152	Tension Roller		2
53	2244OSC-153	Bracket		2
54	BB-6205VV	Ball Bearing	6205VV	2
55	TS-0561021	Hex Nut	5/16-18	4

Drum Head Assembly

Index No.	Part No.	Description	Size	Qty
56	2244OSC-156	Retaining Ring		1
57	BB-6000ZZ	Ball Bearing	6000ZZ	1
58	2244OSC-158	Link		1
59	2244OSC-159	Retaining Ring		1
60	2244OSC-160	Bracket		1
61	2244OSC-161	Shoulder Screw		1
62	2244OSC-162	Thread Bushing		1
63	20-0778	Retaining Ring		2
64	TS-0152021	Carriage Bolt	5/16-18x1-1/4	2
65	2244OSC-165	Bearing Housing		2
66	TS-1550031	Flat Washer	M5	4
67	TS-1533032	Pan Head Machine Screw	M5x10	4
68	2244OSC-168	Gearbox Cover		1
69	2244OSC-169	Bracket, Left Tension Roller		2
70	12-9001	Nylon Insert Lock Nut	#6-32	2
71	21-1172	Fastener, Abrasive Inboard		1
72	10-3003	Screw, Flat Head-Phillips	#6-32x3/8	2
73	2244OSC-173	Dust Cover		1
74	80-3137	Knob		1
75	2244OSC-175	Dust Cover Latch		1
76	TS-081F052	Pan Head Machine Screw	1/4-20x3/4	3
77	2244OSC-177	Retaining Ring		1
78	2244OSC-178	Bearing	688ZZ	1
79	2244OSC-179	Upper Sliding Drum Carriage		1
80	21-1173	Fastener, Abrasive Outboard		1
81	TS-0254061	Button Head Socket Screw	1/4-20x1	3
82	TS-0267021	Set Screw	1/4-20x1/4	1
83	2244OSC-183	Lower Fixed Drum Carriage		1
84	TS-0254041	Button Head Socket Screw	1/4-20x3/4	6
85	2244OSC-185	Shaft		2
86	TS-0640091	Nylon Insert Lock Nut	3/8-16	1
87	TS-0732041	Internal Tooth Lock Washer	1/4	2
88	40-3166	Dust Cover Catch		1
89	TS-0060081	Hex Cap Screw	3/8-16x1-3/4	1
90	TS-0561011	Hex Nut	1/4-20	2
91	TS-0152041	Carriage Bolt	5/16-18x1-3/4	2
92	TS-0255061	Button Head Socket Screw	5/16-18x1	2
93	2244PLUS-254	Hinge Pin		2
95	TS-0267071	Set Screw	1/4-20x3/4	3
96	2244OSC-196	Holder		1
97	2244OSC-197	Gib		4
98	2244OSC-198B	Sanding Drum (serial # 11121604 and higher)		1
99	2244OSC-199	Button Head Socket Screw	5/16-18x1-1/4	2
100		Abrasive ¹	3-1/8 width	1
103	2244OSC-1103	Retaining Ring		2
105	80-1060	Bracket Pad, Tension Roller		1
106	2244OSC-1113	Glider		2
107	2244OSC-1114	Socket Head Cap Screw	M6	2
108	2244OSC-1115	Plate		2
109	2244OSC-1116	Nylon Insert Lock Nut	M6	2
	98-0060	TufTool (not shown)		1

¹ contact Walter Meier (Manufacturing) Inc., to find replacement abrasives

Conveyor and Motor Assembly – Exploded View

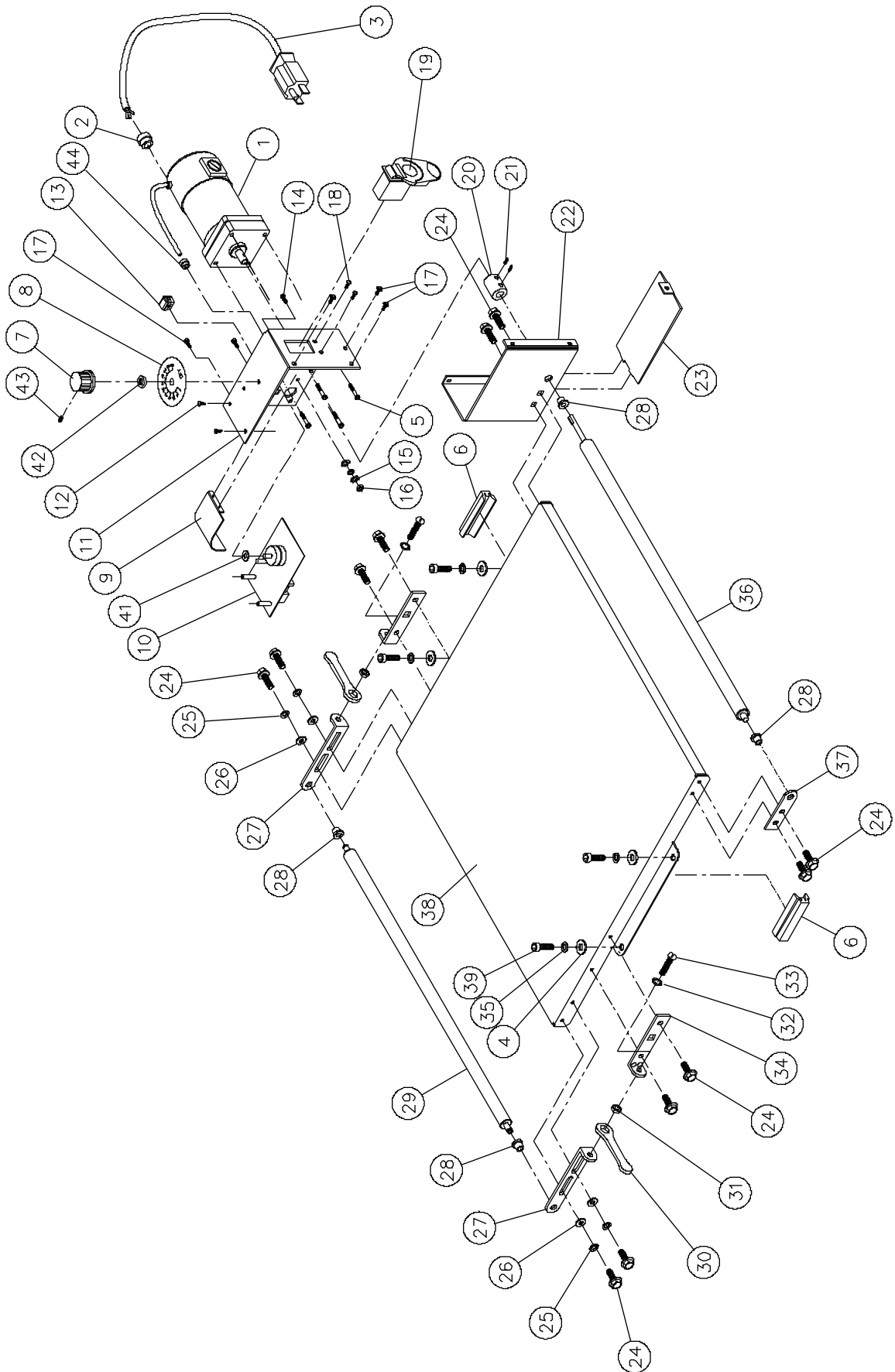

Conveyor and Motor Assembly – Parts List

Index No.	Part No.	Description	Size	Qty
1	323759	Gear Motor	90 Volt DC	1
2	72-6014	Strain Relief		1
3	72-5336	Cord Set	110-120V-75"	1
4	TS-0680031	Flat Washer	5/16	4
5	10-4010-08	Socket Head Cap Screw	#10-32x1/2	4
6	98-0080A	Tracker Kit		2
7	72-2250-01	Knob		1
8	72-2250-02	Speed Adjusting Label		1
9	40-4018	Wiring Guard		1
10	72-2250	SandSmart Controller		1
11	40-4904	Controller Housing Bracket		1
12	20-0777	Pan Head Self-Tapping Screw	5/32x1/2	2
13	72-2120	Receptacle, 110-120Volt		1
14	TS-081D032	Pan Head Machine Screw	#10-32x1/2	1
15	TS-073203	Internal Tooth Lock Washer	#10	2
16	TS-0560081	Hex Nut	#10-32	2
17	10-9002	Slotted Hex Head Screw	#10-32x1/2	5
18	10-3103	Phillips Pan Head Screw	#6-32x1/2	2
19	72-2004	ON/OFF Drum Switch		1
20	30-0122	Shaft Coupler		1
21	TS-0267021	Set Screw	1/4-20x1/4	2
22	40-4903	Controller Base Bracket		1
23	40-4022W	Control Housing Base Cover		1
24	10-4004-12	Hex Washer Head Bolt	1/4-20x3/4	12
25	20-1161-01	Wave Washer	1/4	4
26	TS-0680021	Flat Washer	1/4	4
27	40-0003	Take Up-Slide Bracket		2
28	50-3105	Oilite Bushing	5/16" I.D.	4
29	30-3010-10	Driven Roller		1
30	40-0260	Wrench		2
31	TS-0561011	Hex Nut	1/4-20	2
32	TS-0732041	Internal Tooth Lock Washer	1/4	2
33	10-4007-24	Slotted Round Head Screw	1/4-20x1-3/4	2
34	40-4004	Take-Up Bracket Base		2
35	TS-0720081	Lock Washer	5/16	4
36	30-3010-11	Drive Roller		1
37	40-0005	Drive Roller Support Bracket		1
38	40-4010-01	Conveyor Bed		1
39	TS-0208041	Socket Head Cap Screw	5/16-18x3/4	4
	60-0322-P	Conveyor Belt (not shown)		1
41	72-2250-03	Washer	5/16	1
42	72-2250-04	Hex Nut	5/16-24	1
43	72-2250-05	Slotted Set Screw	#8-36UNFx5/16	1
44	72-6101	Small Strain Relief		1

Gearbox Assembly

Index No.	Part No.	Description	Size	Qty
	2244OSC-GBA	Gearbox Assembly		1
1	2244OSC-201	Rubber Cover		1
2	2244OSC-202	Gear		1
3	BB-6002ZZ	Ball Bearing	6002ZZ	2
4	2244OSC-204	Retaining Ring		2
5	2244OSC-205	Gearbox		1
6	2244OSC-206	Eccentric Shaft		1
7	2244OSC-207	Key	4x4x18	2
8	2244OSC-208	Worm		1
9	BB-6001ZZ	Ball Bearing	6001ZZ	2
10	2244OSC-210	Retaining Ring		1
11	2244OSC-211	Set Screw	#10-24x1/4	2
12	2244OSC-212	Clutch Bushing		1
13	BB-6004ZZ	Ball Bearing	6004ZZ	1
14	2244OSC-214	Pulley Base		1
15	2244OSC-215	Pulley		1
16	2244OSC-216	Pulley Shield		1
17	2244OSC-217	Retaining Ring		1
18	2244OSC-218	Clutch Knob		1
19	2244OSC-219	Pin		1
20	2244OSC-220	Screw	#10-24x7/8	5
21	2244OSC-221	Set Screw w/Steel Ball	M4x9	1
22	TS-0640091	Nylon Insert Lock Nut	3/8-16	1
23	TS-0680011	Flat Washer	3/16	5

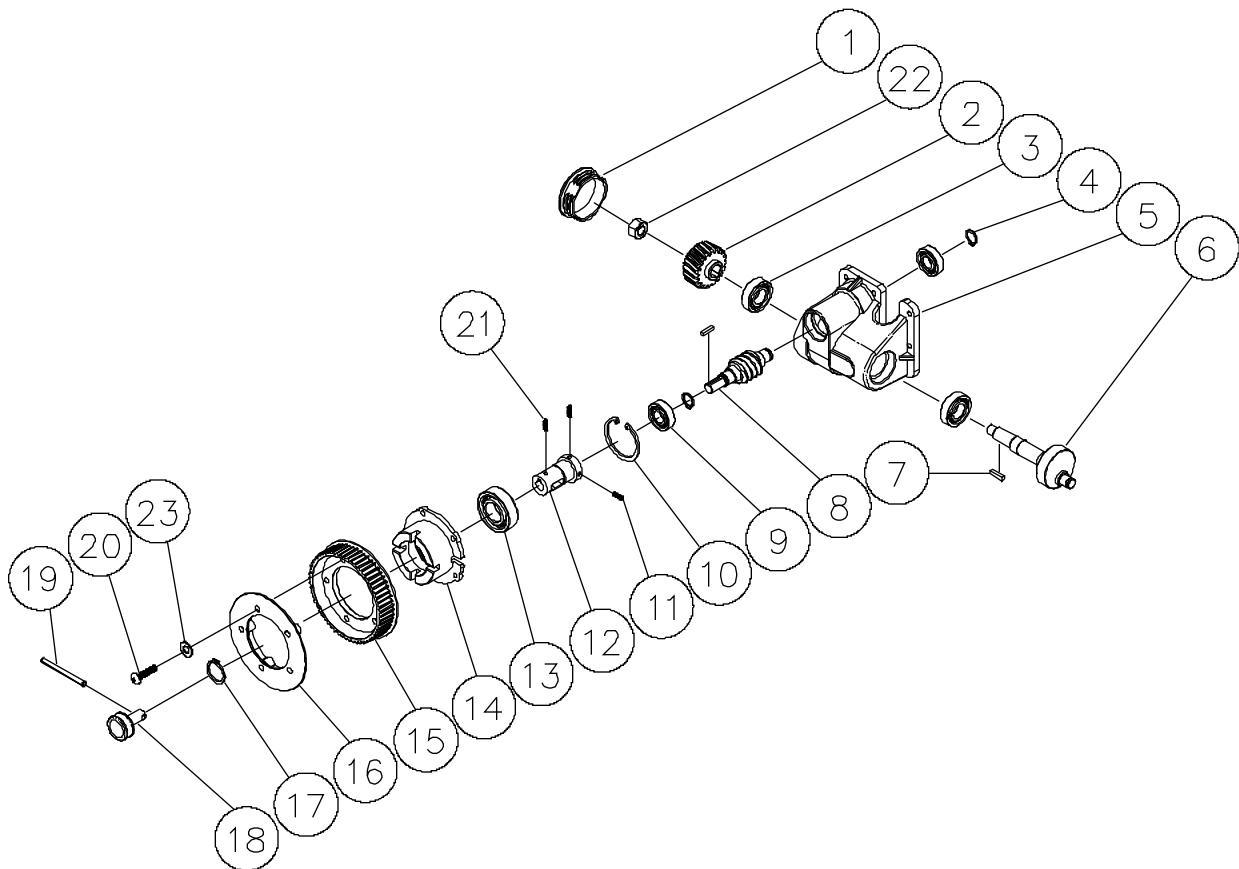

Closed Stand Assembly

Index No.	Part No.	Description	Size	Qty
.....	659006S	Closed Stand Assembly
1.....	2244OSC-301	Stand Side	2
2.....	TS-0680041	Flat Washer	3/8	4
3.....	TS-0060051	Hex Cap Screw	3/8-16x1	4
4.....	TS-0051011	Hex Cap Screw	5/16-18x1/2	12
5.....	TS-0680031	Flat Washer	5/16	12
6.....	2244OSC-306	Bottom Plate	1
7.....	2244OSC-307	Rear Plate	1
8.....	2244OSC-308	Front Plate	1
9.....	80S-416	Door Hinge	1
10.....	TS-0561011	Hex Nut	1/4-20	2
11.....	80S-413	Screw	M3x4	2
12.....	2244OSC-312	Door	1
13.....	80S-414	Latch	1
14.....	TS-081F032	Pan Head Machine Screw	1/4-20x1/2	2

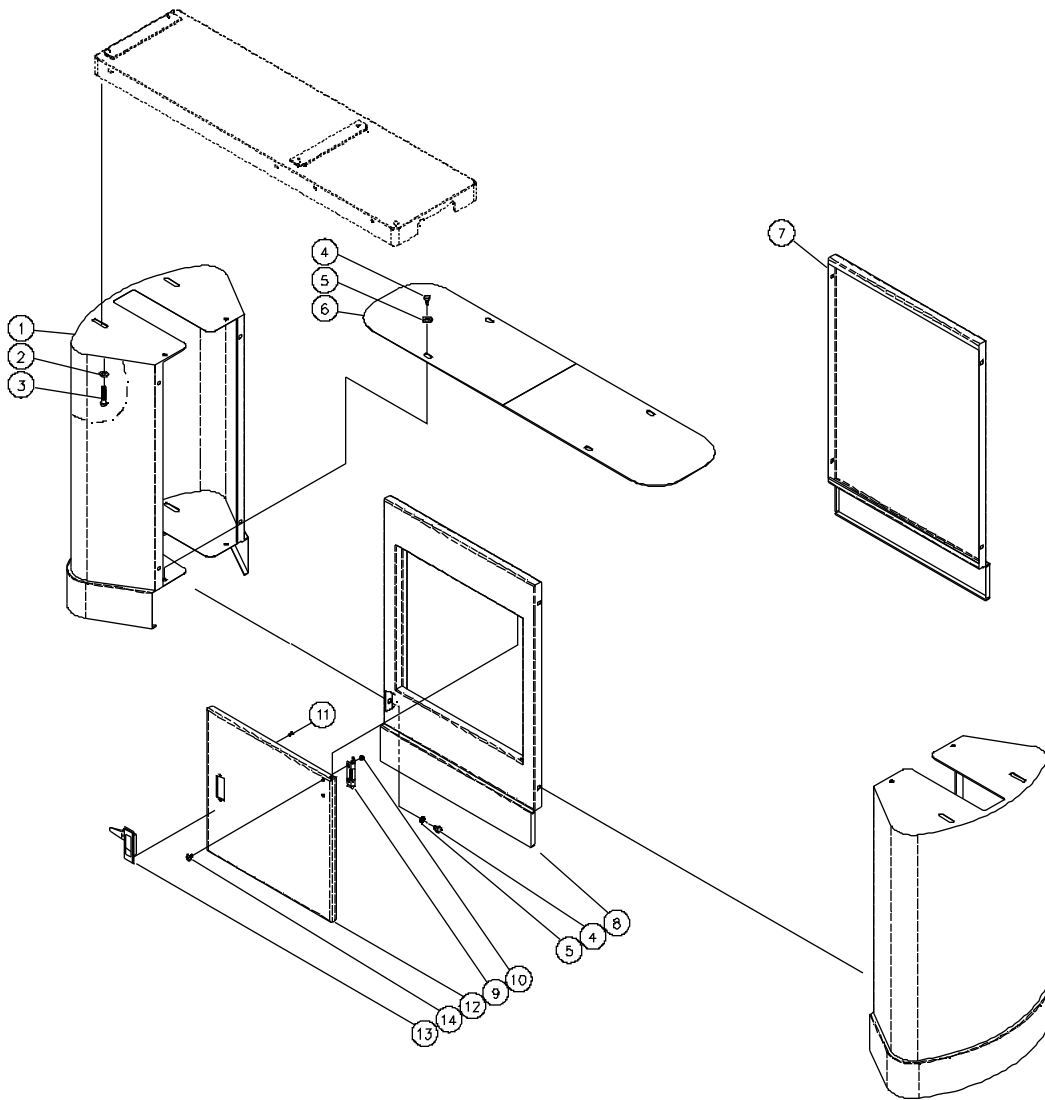

Infeed and Outfeed Tables

Optional Accessory – Stock No.: 98-2202

Index No.	Part No.	Description	Size	Qty
1	2244PLUS-501	Table		2
2	2244PLUS-502	Base Bracket		2
3	TS-0060051	Hex Cap Screw	3/8-16x1	4
4	TS-0680041	Flat Washer	3/8	4
5	TS-0151011	Carriage Bolt	1/4-20x3/4	8
6	TS-0680021	Flat Washer	1/4	8
7	TS-0561011	Hex Nut	1/4-20	8

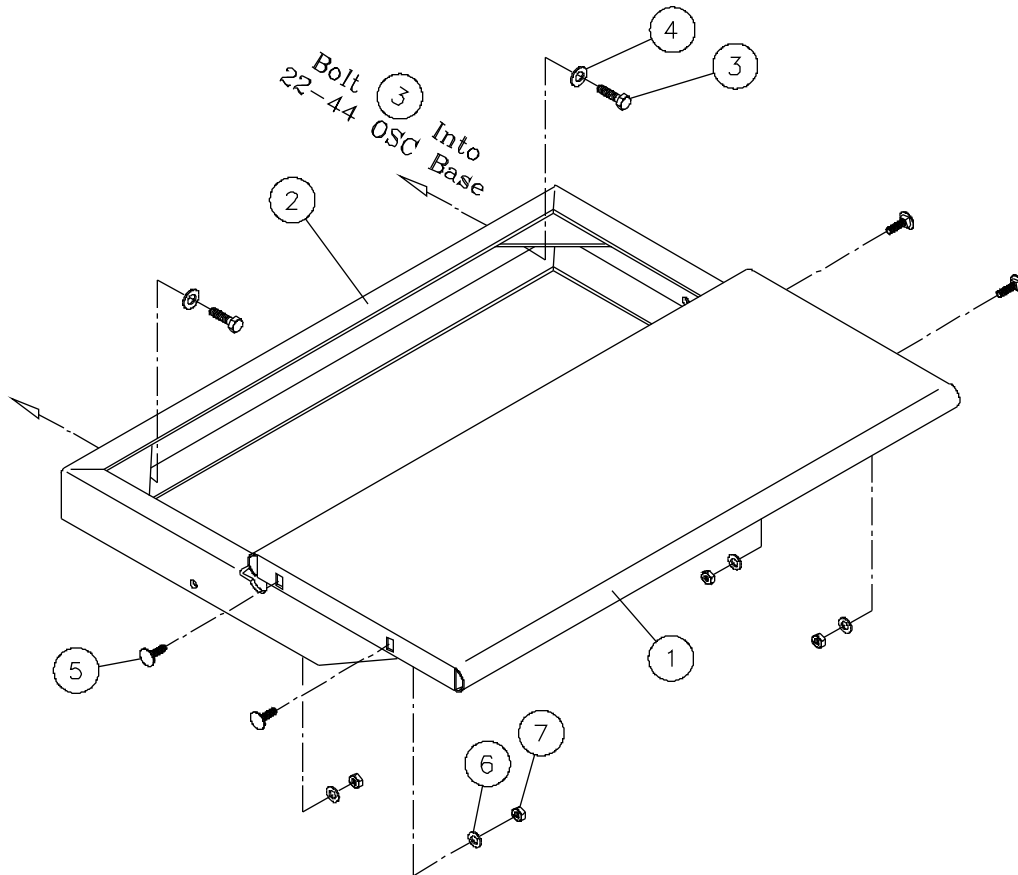

Wiring Diagram

GEARMOTOR CONTROLLER SCHEMATIC
110V AC TO VARIABLE 90V DC

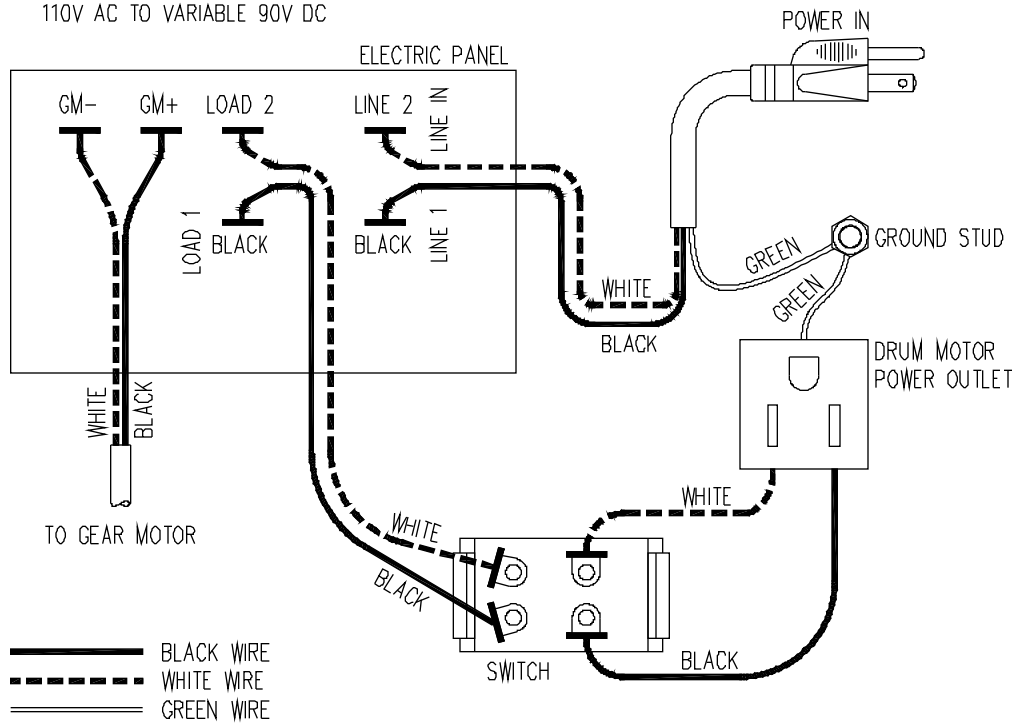



WALTER MEIER (Manufacturing) Inc.

427 New Sanford Road
LaVergne, Tennessee 37086
Phone: 800-274-6848
www.waltermeier.com