



# Operating Instructions and Parts Manual

## Left Tilting Arbor Saw

Models JTAS-10XL and JTAS-12XL



JTAS-10XL shown

**WALTER MEIER (Manufacturing) Inc.**  
427 New Sanford Road  
LaVergne, Tennessee 37086  
Ph.: 800-274-6848  
[www.waltermeier.com](http://www.waltermeier.com)

**Part No. M-708661**  
Revision H2 05/2011  
Copyright © 2011 WMH Tool Group, Inc.

## Warranty and Service

Walter Meier (Manufacturing) Inc., warrants every product it sells. If one of our tools needs service or repair, one of our Authorized Service Centers located throughout the United States can give you quick service. In most cases, any of these Walter Meier Authorized Service Centers can authorize warranty repair, assist you in obtaining parts, or perform routine maintenance and major repair on your JET® tools. For the name of an Authorized Service Center in your area call 1-800-274-6848.

### MORE INFORMATION

Walter Meier is consistently adding new products to the line. For complete, up-to-date product information, check with your local Walter Meier distributor, or visit [waltermeier.com](http://waltermeier.com).

### WARRANTY

JET products carry a limited warranty which varies in duration based upon the product (MW = Metalworking, WW = Woodworking).

|   |  |  |   |  |   |
|---|--|--|---|--|---|
| <b>90</b><br>DAY<br>WARRANTY  | <b>1</b><br>YEAR<br>WARRANTY   | <b>2</b><br>YEAR<br>WARRANTY   | <b>3</b><br>YEAR<br>WARRANTY  | <b>5</b><br>YEAR<br>WARRANTY   | <b>LIFE</b><br>LIFETIME<br>WARRANTY   |
| Lathe Accessories<br>Machine Accessories<br>Mobile Bases<br>Safety Equipment<br>Specialty Items<br>Vise Accessories                   | Air Tools-<br>Contractor<br>Air Tools-Industrial<br>Air Tools-Light<br>Industrial<br>Lubrication | Body Repair Kits<br>Bottle Jacks<br>Cable Pullers<br>Cold Saws<br>Hoists-Air<br>Hoists-Electric<br>Metal forming<br>Mill/Drills<br>Milling Machines<br>MW Bandsaws<br>MW Drill Presses<br>MW Finishing<br>Equipment<br>MW Lathes<br>MW Precision Vises | Palet Trucks<br>Rigging Equip.<br>Service Jacks<br>Stackers<br>Surface Grinders<br>Tapping<br>Trolleys-Air<br>Trolleys-Electric<br>Web Slings<br>Winches-Electric | Beam Clamps<br>Chain Hoist-<br>Manual<br>Lever Hoists<br>Pullers-JCH Models<br>Scissor Lift Tables<br>Screw Jacks<br>Trolleys-Geared<br>Trolleys-Plain<br>Winches-Manual<br>WW Air Filtration<br>WW Bandsaws<br>WW Buffers | WW Drill Presses<br>WW Dust Collectors<br>WW Dust Filters<br>WW Dust Fittings<br>WW Jointers<br>WW Lathes<br>WW Planers<br>WW Sanders<br>WW Shapers<br>WW Tablesaws |
| <i>Warranty reverts to 1 Year Warranty if woodworking (WW) products listed above are used for industrial or educational purposes.</i> |  |  |   |  |   |

### WHAT IS COVERED?

This warranty covers any defects in workmanship or materials subject to the exceptions stated below. Cutting tools, abrasives and other consumables are excluded from warranty coverage.

### WHO IS COVERED?

This warranty covers only the initial purchaser of the product.

### WHAT IS THE PERIOD OF COVERAGE?

The general JET warranty lasts for the time period specified in the product literature of each product.

### WHAT IS NOT COVERED?

Five Year Warranties do not cover woodworking (WW) products used for commercial, industrial or educational purposes. Woodworking products with Five Year Warranties that are used for commercial, industrial or education purposes revert to a One Year Warranty. This warranty does not cover defects due directly or indirectly to misuse, abuse, negligence or accidents, normal wear-and-tear, improper repair or alterations, or lack of maintenance.

### HOW TO GET SERVICE

The product or part must be returned for examination, postage prepaid, to a location designated by us. For the name of the location nearest you, please call 1-800-274-6848.

You must provide proof of initial purchase date and an explanation of the complaint must accompany the merchandise. If our inspection discloses a defect, we will repair or replace the product, or refund the purchase price, at our option. We will return the repaired product or replacement at our expense unless it is determined by us that there is no defect, or that the defect resulted from causes not within the scope of our warranty in which case we will, at your direction, dispose of or return the product. In the event you choose to have the product returned, you will be responsible for the shipping and handling costs of the return.

### HOW STATE LAW APPLIES

This warranty gives you specific legal rights; you may also have other rights which vary from state to state.

### LIMITATIONS ON THIS WARRANTY

WALTER MEIER (MANUFACTURING) INC., LIMITS ALL IMPLIED WARRANTIES TO THE PERIOD OF THE LIMITED WARRANTY FOR EACH PRODUCT. EXCEPT AS STATED HEREIN, ANY IMPLIED WARRANTIES OR MERCHANTABILITY AND FITNESS ARE EXCLUDED. SOME STATES DO NOT ALLOW LIMITATIONS ON HOW LONG THE IMPLIED WARRANTY LASTS, SO THE ABOVE LIMITATION MAY NOT APPLY TO YOU.

WALTER MEIER SHALL IN NO EVENT BE LIABLE FOR DEATH, INJURIES TO PERSONS OR PROPERTY, OR FOR INCIDENTAL, CONTINGENT, SPECIAL, OR CONSEQUENTIAL DAMAGES ARISING FROM THE USE OF OUR PRODUCTS. SOME STATES DO NOT ALLOW THE EXCLUSION OR LIMITATION OF INCIDENTAL OR CONSEQUENTIAL DAMAGES, SO THE ABOVE LIMITATION OR EXCLUSION MAY NOT APPLY TO YOU.

Walter Meier sells through distributors only. The specifications in Walter Meier catalogs are given as general information and are not binding. Members of Walter Meier reserve the right to effect at any time, without prior notice, those alterations to parts, fittings, and accessory equipment which they may deem necessary for any reason whatsoever. JET® branded products are not sold in Canada by Walter Meier.

# Warnings

**Wear eye protection.**

**Use the saw blade guard and splitter for every operation for which it can be used, including all through sawing.**

**Keep hands out of line with the saw blade.**

**Use a push stick when required.**

**Pay particular attention to instructions on reducing the risk of kickback.**

**Do not perform any operation freehand.**

**Never reach around or over the saw blade.**

1. **Read and understand the entire instruction manual before attempting assembly or operation.**
2. **This table saw is designed and intended for use by properly trained and experienced personnel only. If you are not familiar with the proper and safe operation of a table saw, do not use until proper training and knowledge have been obtained.**
3. Always wear approved safety glasses/face shields while using this machine.
4. Make certain the machine is properly grounded.
5. Before operating the machine, remove tie, rings, watches, other jewelry, and roll up sleeves above the elbows. Remove all loose clothing and confine long hair. Do **not** wear gloves.
6. Keep the floor around the machine clean and free of scrap material, oil and grease.
7. Keep machine guards in place at all times when the machine is in use. If removed for maintenance purposes, use extreme caution and replace the guards immediately.
8. Do **not** over reach. Maintain a balanced stance at all times so that you do not fall or lean against blades or other moving parts.
9. Make all machine adjustments or maintenance with the machine unplugged from the power source.
10. Use the right tool. Don't force a tool or attachment to do a job that it was not designed for.
11. Replace warning labels if they become obscured or removed.
12. Make certain the switch is in the **OFF** position before connecting the machine to the power supply.
13. Give your work undivided attention. Looking around, carrying on a conversation, and "horse-play" are careless acts that can result in serious injury.
14. Keep visitors a safe distance from the work area.
15. Use recommended accessories; improper accessories may be hazardous.
16. Never place hands directly in line with the saw blade.
17. Always use push sticks when cutting small material.
18. Raise or lower the blade only when the machine has been turned off and the blade has come to a complete stop.
19. Read and understand warnings posted on the machine.
20. Use blade guard for every applicable operation including all through cuts. If guard is removed for special non-through cuts such as dado and rabbet cuts, replace before further use of the saw.
21. Failure to comply with all of these warnings may cause serious injury.
22. Some dust created by power sanding, sawing, grinding, drilling and other construction activities contains chemicals known to cause cancer, birth defects or other reproductive harm. Some examples of these chemicals are:
  - Lead from lead based paint
  - crystalline silica from bricks and cement and other masonry products, and
  - arsenic and chromium from chemically-treated lumber.Your risk from those exposures varies, depending on how often you do this type of work. To reduce your exposure to these chemicals: work in a well ventilated area, and work with approved safety equipment, such as those dust masks that are specifically designed to filter out microscopic particles.
23. Do not operate tool while under the influence of drugs, alcohol or any medication.

## Introduction

The JET JTAS-10XL or JTAS-12XL tablesaw you have purchased is a high quality machine tool that will give you years of superior service. You will get maximum performance and enjoyment from your new table saw if you will take a few moments now to review the entire manual before beginning assembly and operation.

This tablesaw, as well as all JET products, are backed by a nationwide network of authorized distributors and/or service centers. Please contact your nearest distributor should you require parts or service. Parts are also available directly from Walter Meier (Manufacturing) Inc., by calling 1-800-274-6848.

Now that you have purchased a tablesaw, it is a good time to consider a dust collection system. See your local JET distributor for the complete line of dust collectors and the full line of JET Dust Collector Hoses and Accessories. Customize your installation and obtain maximum performance with JET's dust hoods, hoses, clamps, fittings, and blast gates.

Assembling and fine tuning a tablesaw, fence and rail system, extension tables, etc. can be a time consuming project. It is best not to rush. The tablesaw does not come with a plug. Purchase a plug that matches the 230V or 460V outlet that will be used. The tablesaw does not come with a blade so you may want to purchase a variety of blades for different applications.

## Table of Contents

|   |       |
|---|-------|
| Warranty .....  | 2     |
| Warnings .....  | 3     |
| Introduction.....   | 4     |
| Table of Contents.....  | 4     |
| Specifications .....  | 5     |
| Contents of the Shipping Container.....                             | 6     |
| Tools Required for Assembly .....                                   | 6     |
| Unpacking and Cleanup .....   | 6     |
| Installation and Leveling.....                                      | 7     |
| Motor Cover Assembly .....  | 7     |
| Extension Wing Assembly.....  | 7     |
| Hand Wheel Assembly.....  | 8     |
| Blade Guard Assembly.....   | 8     |
| Installing Blade.....   | 9     |
| Aligning Blade Guard and Splitter .....                             | 9     |
| Table Insert Adjustment.....  | 10    |
| Mounting Rails and Extension Table.....                             | 10    |
| Attaching Switch Bracket Assembly and Switch Brace to the Saw ..... | 10    |
| Miter Gauge Operation.....  | 10    |
| Blade Raising and Tilting Mechanism .....                           | 11    |
| Electrical Connections .....  | 11    |
| Blade Alignment .....   | 12    |
| Adjusting 45° and 90° Positive Stops .....                          | 13    |
| Changing Belts.....   | 14    |
| Maintenance .....   | 14    |
| Optional Accessories.....   | 14    |
| Troubleshooting .....   | 15    |
| Parts Breakdown and Parts List.....                                 | 16-31 |
| Electrical Schematic.....   | 32-33 |

## Specifications

## JTAS-10XL

|  |   |
|--|---|
| Stock Number .....                               | 708661 (3 HP, 1 Ph)                       |
| .....  | 708666 (5 HP, 1 Ph)                       |
| .....  | 708664 (5 HP, 3 Ph)                       |
| Blade Diameter .....                             | 10"                                       |
| Arbor Diameter .....                             | 5/8"                                      |
| Maximum Depth of Cut .....                       | 3"  |
| Maximum Thickness at 45° Cut .....               | 2-1/8"                                    |
| Table in Front of Saw Blade at Maximum Cut ..... | 12"                                       |
| Maximum Width of Dado .....                      | 13/16"                                    |
| Maximum Diameter of Dado .....                   | 8"  |
| Dust Port Diameter .....                         | 4"  |
| Table Height .....                               | 34"                                       |
| Table Size (with extension) .....                | 27"D x 40"W                               |
| Table Size (without extension) .....             | 27" D x 20"W                              |
| Arbor Speed .....                                | 4200 RPM                                  |
| Motor .....                                      |   |
| JTAS-10XL-1 .....                                | 3HP, 1Ph, <b>230V only</b>                |
| JTAS-10XL-5/1 .....                              | 5 HP, 1Ph, <b>230V only</b>               |
| JTAS-10XL-3 .....                                | 5HP, 3Ph, 230/460V, <b>prewired 230V*</b> |
| Net Weight (approx.) .....                       | 374 lbs.                                  |

## Specifications

## JTAS-12XL

|  |  |
|--|--|
| Stock Number .....                               | 708537 (5 HP, 1 Ph)                        |
| .....  | 708542 (5 HP, 3 Ph)                        |
| Blade Diameter .....                             | 12"  |
| Arbor Diameter .....                             | 1"   |
| Maximum Depth of Cut .....                       | 4"   |
| Maximum Thickness at 45° Cut .....               | 2-7/8"                                     |
| Table in Front of Saw Blade at Maximum Cut ..... | 12"  |
| Maximum Width of Dado .....                      | 13/16"                                     |
| Maximum Diameter of Dado .....                   | 8"   |
| Dust Port Diameter .....                         | 4"   |
| Table Height .....                               | 34"  |
| Table Size (with extension) .....                | 29"D x 44"W                                |
| Table Size (without extension) .....             | 29" D x 22"W                               |
| Arbor Speed .....                                | 4200 RPM                                   |
| Motor .....                                      |  |
| JTAS-12XL-5/1 .....                              | 5HP, 1Ph, <b>230V only</b>                 |
| JTAS-12XL-3 .....                                | 5 HP, 3Ph, 230/460V, <b>prewired 230V*</b> |
| Net Weight (approx.) .....                       | 396 lbs.                                   |

*\*Conversion to 460V requires the purchase and installation of switch #JTAS10-23B.*

The JTAS-10XL and JTAS-12XL Tilting Arbor Tablesaws are designed to allow the use of several precision fences by various manufacturers. Please follow the directions for mounting the fence and rails that come with the fence system you have purchased.

The specifications in this manual are given as general information and are not binding. Walter Meier (Manufacturing) Inc, reserves the right to effect, at any time and without prior notice, changes or alterations to parts, fittings, and accessory equipment deemed necessary for any reason whatsoever.

## WARNING

Read and understand the entire contents of this manual before attempting assembly or operation!

Failure to comply may cause serious injury!



### Contents of the Shipping Container

1. Saw
1. Motor Cover
2. Extension Wings

### Accessory Package:

1. Blade Guard Assembly
1. Hand Wheel / Handle Assembly
1. Lock Knob
1. Arbor Wrench
1. Miter Gauge Assembly
1. Blade Guard Wrench w/ Cable
1. Switch Brace
1. 8mm Hex Wrench
1. Blade Guard Mounting Bracket Assembly

**Note:** The blade guard wrench attached to the blade guard shaft with a cable is included for your convenience. Install the blade guard shaft assembly as shipped and the wrench will always be immediately available to adjust, install, or remove the blade guard assembly. **Always use the blade guard whenever possible. If making cuts that require the removal of the blade guard, use extreme caution. Replace the blade guard immediately after finishing those cuts that require its removal.**

### Tools Required for Assembly

Metric Wrench Set or 6"-8" Adjustable Wrench  
Metric Hex Wrench Set  
Straight Edge

### Unpacking and Clean-Up

- **Tool:** 12mm Wrench
1. Remove all contents from the shipping container. Do not discard any shipping material until the saw is set up and running satisfactorily.
  2. Inspect contents for shipping damage. Report damage, if any, to your local distributor.
  3. Remove two hex cap bolts from skid bottom.
  4. Carefully move saw to its final location.

## WARNING

Do not connect the tablesaw to the power source until all assembly has been completed!

Failure to comply may cause serious injury!

### Installation and Leveling

Final location for the saw must be level, dry, well lighted, and have enough room to allow movement around the saw with long pieces of wood stock.

Level the saw front to back and side to side using a carpenter's level placed on the table. Use shims under the corners, if necessary, but make sure the saw is stable before being placed into service.

### Motor Cover Assembly

- **Tools:** 17mm Wrench, 12mm Wrench
1. Remove shipping bracket (A, Fig. 1) securing the motor to table.
  2. After the shipping bracket has been removed, install the bolt (B, Fig. 1) back into the motor support bracket. Upper bolt will be used to hold the extension wing in place.
  3. Remove shipping bracket (C, Fig. 1) holding switch assembly to table. Do **not** discard the hardware.
  4. Remove remaining hex cap bolt, lock washer, and flat washer in the table edge.
  5. Install motor cover (A, Fig. 2) by aligning pins (B, Fig. 2) on cover with brackets on cabinet.
  6. Fasten cover by pulling out latch (C, Fig. 2), closing the door, and releasing the latch.

### Extension Wing Assembly

- **Hardware:** (6) 7/16" x 1-1/2" Hex Cap Bolts, (6) 7/16" Lock Washers, (6) 7/16" Flat Washers & (2) Extension Wings
  - **Tools:** 17mm Wrench, Straight Edge
1. Attach extension wings to the table with six hex cap bolts, six lock washers and six flat washers. Snug but do not tighten
  2. Slide extension wings toward the front edge of the saw table until two edges are flush.

3. Using a straight edge (A, Fig. 3), align the extension wings to the saw table and tighten the hex cap bolts.



Fig. 1

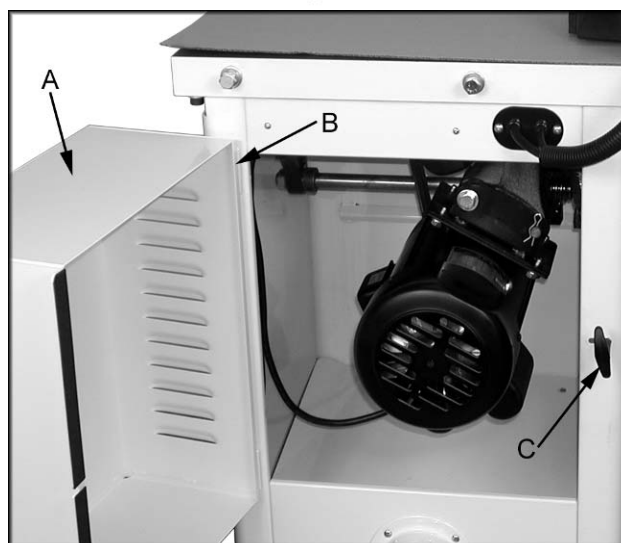

Fig. 2



Fig. 3

## Handwheel Assembly

- **Hardware:** Handle & Hand Wheel, Lock Knob
  - **Tool:** 3mm Hex Wrench
1. Line up the key on the shaft with the key way in the handwheel (A, Fig. 4) and slide the handwheel onto the shaft.
  2. Tighten the set screw on the handwheel hub securely to hold in place.
  3. Install center lock knob (B, Fig. 4) by inserting into center hole in the shaft and threading in a clockwise direction.

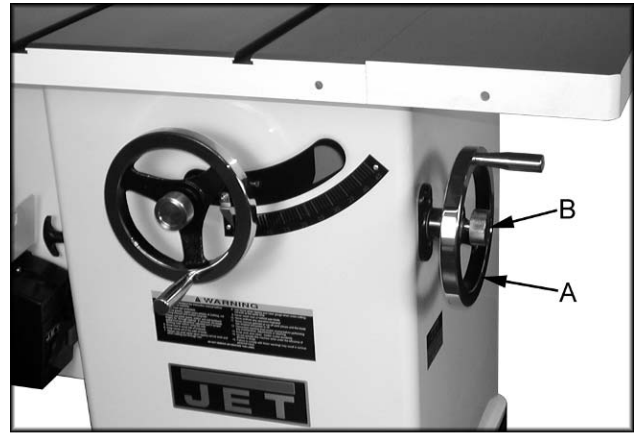

Fig. 4

## Blade Guard Assembly

- **Hardware:** Blade Guard Assembly, Blade Guard Mounting Bracket Assembly, Blade Guard Wrench w/Cable and M16 Lock Washer
- **Tools:** 12mm Wrench, 17mm Wrench or Adjustable Wrench, 4mm Hex Wrench

1. Place the closed loop end of the cable (A, Fig. 5) with the attached blade guard wrench over the blade guard shaft.
2. Place a 5/8" lock washer (B, Fig. 5) onto the threaded portion of the blade guard shaft.
3. Thread blade guard shaft into rear trunnion through opening at rear of saw.
4. Tighten blade guard shaft. The blade guard post has a flat detent to accommodate a wrench.
5. Place upper and lower bracket assembly in the upright position and snug two set screws (C, Fig. 5) just enough to hold in place. Do not tighten firmly at this time.
6. Insert front tab of blade guard assembly through insert opening in the table. Loosen the hex cap screw (A, Fig. 6) already installed at the factory and insert the front tab of the blade guard. The tab is held in place between the flat washer and bracket. Finger tighten only at this time.
7. Hold rear tab of blade guard assembly to the upper blade guard bracket with two hex cap bolts (B, Fig. 6). Finger tighten only at this time.
8. A blade will need to be installed before final adjustment can be made.



Fig. 5



Fig. 6



## Installing Blade

### WARNING

When installing or changing saw blade, always disconnect saw from the power source!

Failure to comply may cause serious injury!

- **Hardware:** Blade
  - **Tool:** Arbor Wrench, Scrap Piece of Wood
1. Raise the blade arbor fully and lock the saw at zero by tightening the lock knob in the middle of the handwheel.
  2. Remove the arbor nut and flange.
  3. Place the blade on the arbor shaft making sure the teeth point down at the front of the saw. Replace the flange (A, Fig. 7) and the arbor nut (B, Fig. 7).
  4. Place a wood scrap in the blade's teeth at the rear of the machine. Hold the block of wood in such a way that if it slips or the blade turns, your hand will not contact the blade.
  5. Using the wrench provided, securely tighten the arbor nut. Remove the wrench.

## Aligning Blade Guard and Splitter

- **Tools:** 12mm Wrench, 4mm Hex Wrench, Straight Edge
1. Raise blade guard away from table and hold anti-kickback pawls (A, Fig. 8) away from table surface with the cut-out in the guard arm.
  2. Using an accurate straight edge (B, Fig. 8), align the splitter with the saw blade. Be sure the straight edge rests against body of saw blade and not saw teeth.
  3. When saw blade is aligned with the splitter, carefully tighten the hex cap bolt on the bracket assembly inside the saw.
  4. Make sure the splitter is level with the table and approximately 1/8" above the table before tightening the hardware on the rear of the blade guard assembly. Space between the splitter and the table keeps the splitter

from binding on the table when the blade is tilted to 45°.

5. When saw blade is aligned with the splitter, lower the blade, and tighten all hardware
6. Check alignment again after tightening hardware. Adjust if necessary.

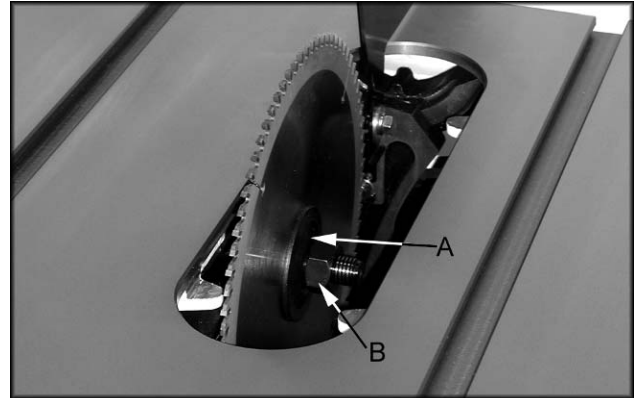

Fig. 7

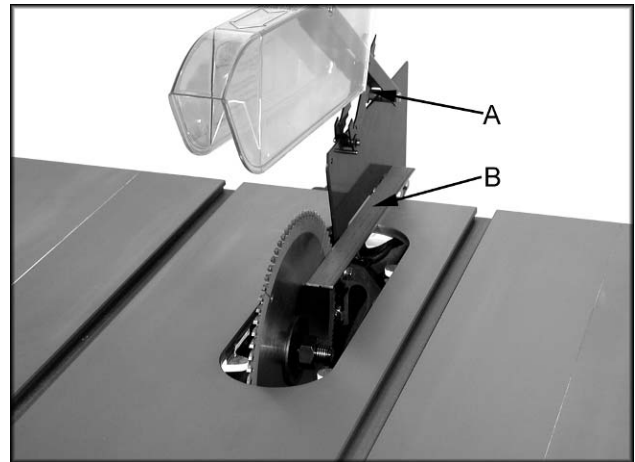

Fig. 8

## Table Insert Adjustment

- **Hardware:** Table Insert
  - **Tools:** Straight Edge, 2.5mm Hex Wrench
1. Lower blade completely.
  2. Place the open end of the insert under the splitter and lower the insert into the opening.
  3. Adjust the table insert flush with the table by turning four leveling screws (A, Fig. 9) and using a straight edge.

## Mounting Rails & Extension Table

With the extension wings properly aligned, the rail and fence assembly can now be mounted to the saw. See the Owner's Manual for the XACTA Fence Assembly Instructions. This will address the mounting of the table, switch, rails and fence.

## Attaching the Switch Bracket Assembly and Switch Brace to the Saw

- **Hardware:** Switch Brace
  - **Tool:** 8mm Hex Wrench, 8mm Wrench
1. Place switch bracket assembly behind both the front fence rail and the lip of the left extension wing. (Do not place between the front fence rail and the extension wing - this will cause the front rail to distort and the fence to bind).
  2. Loosen (do not remove) hex socket cap screw (A, Fig. 10).
  3. Slide the open tab of the switch brace onto the hex socket cap screw and washer. Hand tighten only at this time.
  4. Remove the nut and star washer from the screw at the bottom of the switch plate.
  5. Fasten the switch brace to the switch bracket assembly with the star washer and nut.
  6. Align the switch and tighten all hardware.

## Miter Gauge Operation

1. Operate miter gauge by loosening lock knob (A, Fig. 11) and turning miter body (B, Fig.

11) to desired angle. To move gauge beyond index stops of 45° and 90°, flip down stop (C, Fig. 11).

2. Adjust index stops by turning one of three adjustment screws (D, Fig. 11).

**Note:** Always make test cuts. Do not rely solely on miter gauge indicator marks. There are holes in the miter gauge body that will allow you to mount a wooden extension fence.

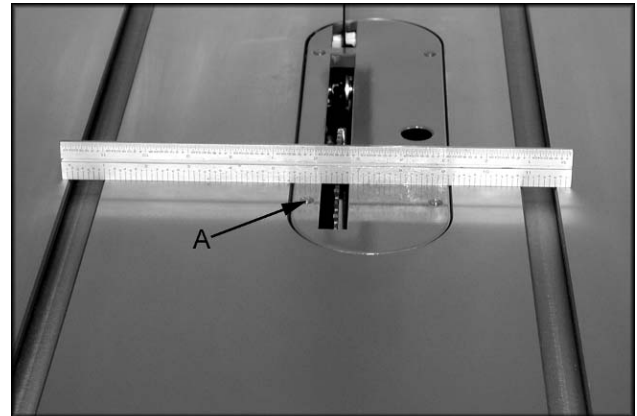

Fig. 9



Fig. 10

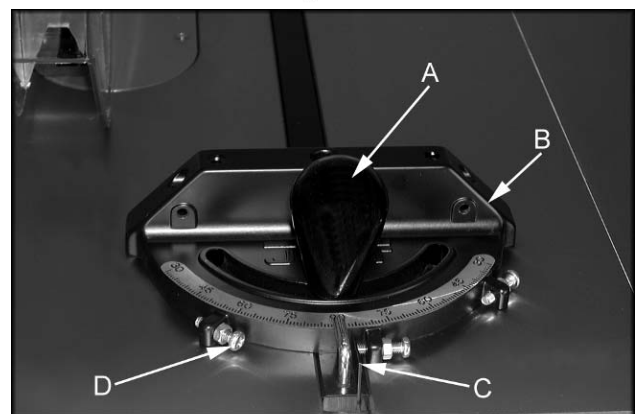

Fig. 11

## Blade Raising and Tilting Mechanism

1. To raise or lower the saw blade, loosen the lock knob (A, Fig. 12) in the middle of the handwheel and turn the handwheel (B, Fig. 12) on the saw front until desired height is reached. Tighten lock knob. The blade should be adjusted 1/8" to 1/4" above the top surface of the material being cut.
2. To tilt the saw blade, loosen lock knob (C, Fig. 12), turn handwheel on the right of the saw cabinet (D, Fig. 12) until desired angle is obtained, then tighten lock knob.

## Electrical Connections

### **WARNING!**

**A qualified electrician must complete all electrical connections!  
Failure to comply may result in serious injury!**

The JTAS-10XL-1, JTAS-10XL-5/1 and JTAS-12XL-5/1 table saws are rated at **230V only**. The JTAS-10XL-3 and JTAS-12XL-3 are rated at 230/460V, and come from the factory **prewired 230V**.

To switch the JTAS-10XL-3 and JTAS-12XL-3 from 230V to 460V:

1. **Disconnect the machine from the power source, (unplug).**
2. Open the saw cabinet door.
3. Remove the cover from the motor junction box.
4. Change wires following the diagram on the inside of the cover.
5. Replace the cover and close the cabinet door.
6. Replace the magnetic on-off switch with part #JTAS10-23B (available through your authorized JET distributor or by calling WMH Tool Group at 1-800-274-6848).

Confirm power at the site is the same as the saw before making any electrical connections. Review the electrical schematics on page 32-33.

The on and off switch is **thermally protected**. If the saw motor is overloaded, or a momentary interruption of electrical current is sensed, the saw will shut off. Allow a few minutes for the saw to cool down and **reset by pushing the off button**.

Using extension cords can cause a loss in power to your machine. It is best if the saw is plugged directly into an outlet on a dedicated circuit.

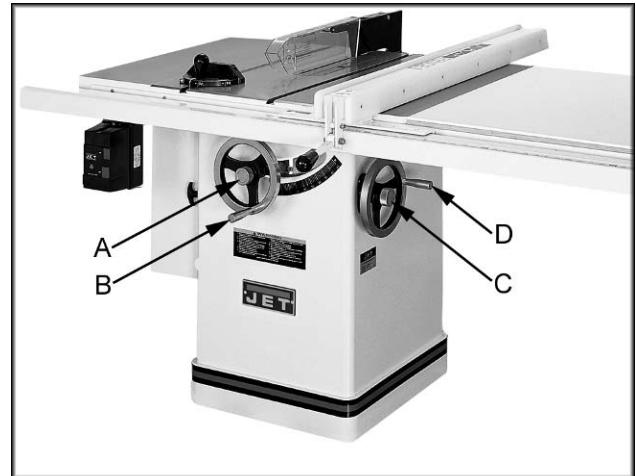

Fig. 12

## Blade Alignment

- **Tool:** 8mm Hex Wrench, combination square, marker

Blade alignment with the table is adjusted at the factory. After a period of use, or, after moving the saw to another location, the blade may no longer be aligned with the table. To check and align the blade: see Figure 13

### 1. Disconnect the saw from the power source.

1. Raise the blade guard up and out of the way of the blade.
2. Unlock fence and move away from the blade so as to expose the right T-slot.
3. Choose a tooth on the far side of the blade and directly over the insert. Mark the tooth with a marker. Measure the distance from the side of the blade to the right T-slot edge using a combination square. Make sure to measure between the teeth not on the tooth, Figure 13.
4. Rotate the blade toward the front so that the marked tooth is just above the insert. Measure the distance from the side of the blade to the right T-slot edge. The two measurements should be the same.
5. If they are not the same, loosen four hex socket cap screws (A, Fig. 14) that hold the table to the base. Two are shown in Figure 14.
6. Make the needed adjustments and tighten the four hex socket cap screws firmly.
7. Check the alignment once again after tightening hardware.

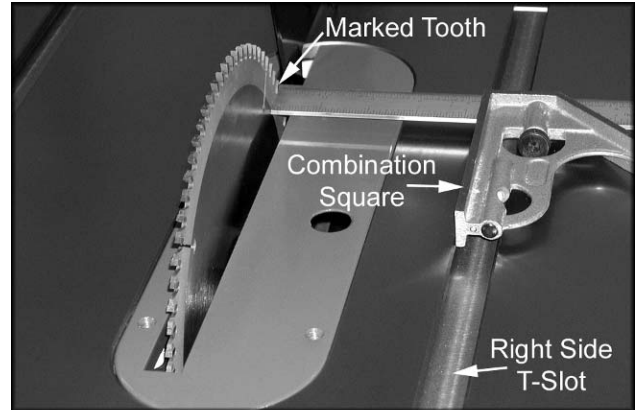

Fig. 13



Fig. 14

## Adjusting 45° and 90° Positive Stops

The stops have been adjusted at the factory. After a period of use, or, after moving the saw to another location, the stops may no longer be set properly. To check and adjust the stops:

- **Tool:** 12mm Wrench, combination square
1. **Disconnect saw from power source.**
  2. Raise the saw blade to its maximum height using the handwheel.
  3. Set the blade at 90 degrees to the table by turning the blade tilting handwheel clockwise as far as it will go.
  4. Place a square on the table and check to see that the blade is at a 90° angle to the table, Figure 15. Make sure square is not touching a blade tooth.
  5. If blade is not at 90 degrees, open the motor cover door, loosen lock nut (A, Fig. 16) and turn adjusting stop screw (B, Fig. 16) on the front trunnion in, or out. The adjusting stop screw should stop against the front trunnion bracket when the blade is 90° to the table.
  6. Tighten the lock nut (A, Fig. 16).
  7. Set the blade at 45 degrees to the table by turning the blade tilting handwheel counter-clockwise as far as it will go. Place a square on the table.
  8. If the blade is not 45 degrees, remove the raising and lowering handle. Loosen lock nut (A, Fig. 17) and turn adjusting stop screw (B, Fig. 17) on the front trunnion in, or out. The adjusting stop screw should stop against the front trunnion bracket when the blade is 45° to the table.
  9. Check the accuracy of the pointer (C, Fig. 17) on the angle scale and adjust, if necessary.

Assembly and adjustment of the saw are now complete. Make sure all fasteners are tight. The saw may now be placed into operation.

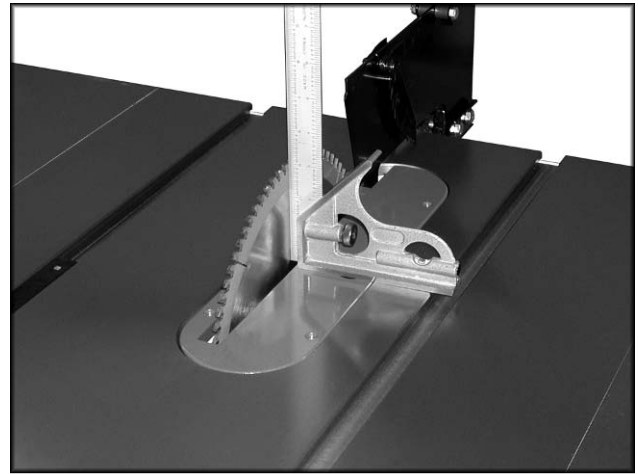

Fig. 15

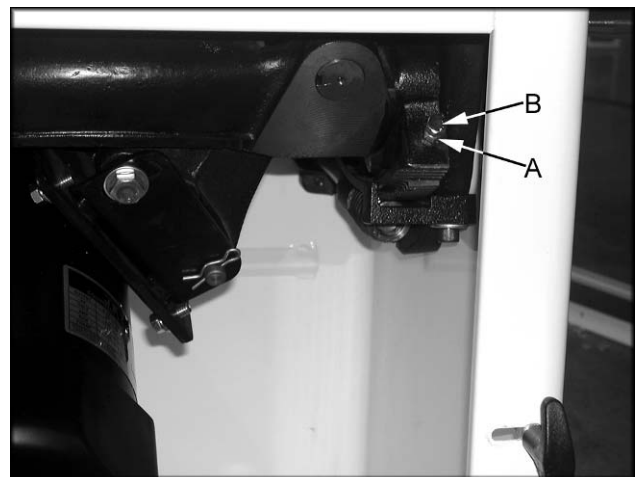

Fig. 16

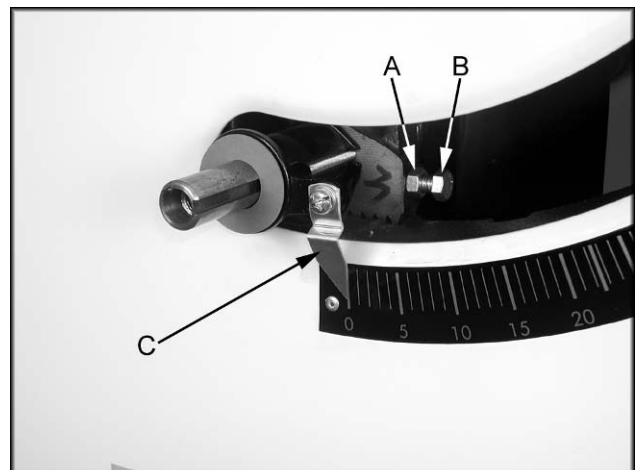

Fig. 17

## Changing Belts

### WARNING

Make all machine adjustments or maintenance with the machine unplugged from the power source.

Failure to comply may cause serious injury!

1. Disconnect the machine from the power source, unplug.
2. Lower the blade to its lowest point.
3. Loosen two hex cap bolts (A, Fig. 18).
4. Take the tension off of the belts (B, Fig. 18) by lifting up on the motor.
5. Remove the belts from the arbor and motor pulleys.
6. Replace and tension the belts. The weight of the motor should apply enough tension to the belts. Tighten the hex cap bolts (A, Fig. 18).
7. Check the belt tension after the saw has been used for a few hours. Adjust as necessary.

## Maintenance

Keep the inside of the cabinet clear of saw dust and wood chips. Vacuum out the inside of the cabinet and blow out the inside with an air hose. Make sure the motor fan and fan cover are also kept clear of sawdust.

Use a wire brush to clean worm gears, and trunnions. Apply white lithium grease or powdered graphite to clean worm gears, and trunnions.

Remove rust from the tabletop with WD-40® and a Scotch-Brite™ Hand Pad. Keep a light coat of WD-40® on the table top when not in use.

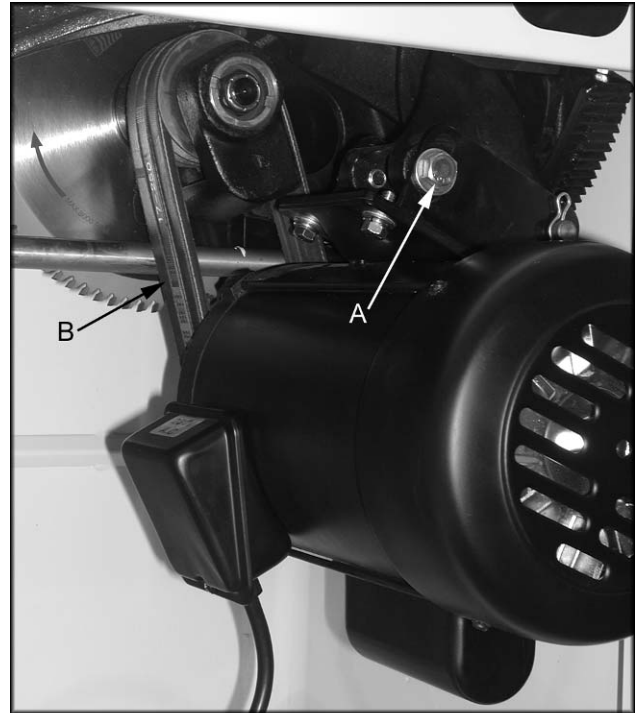

Fig. 18

## Optional Accessories for 10"/12" saws:

|                    |        |
|--------------------|--------|
| XACTA Lift .....   | 708124 |
| Tenoning Jig ..... | 708295 |

### *for 10" saws only:*

|                   |        |
|-------------------|--------|
| Dado Insert ..... | 708109 |
| Mobile Base ..... | 708118 |

### *for 12" saws only:*

|                   |        |
|-------------------|--------|
| Mobile Base ..... | 708119 |
|-------------------|--------|

## Troubleshooting

| Trouble                                       | Possible Cause   | Solution   |
|---|--|--|
| <b>Saw stops or will not start</b>            | <ol style="list-style-type: none"> <li>1. Overload tripped</li> <li>2. Saw unplugged from wall or motor</li> <li>3. Fuse blown or circuit breaker tripped</li> <li>4. Cord damaged</li> </ol>  | <ol style="list-style-type: none"> <li>1. Allow motor to cool and reset by pushing off switch</li> <li>2. Check all plug connections</li> <li>3. Replace fuse or reset circuit breaker</li> <li>4. Replace cord</li> </ol>   |
| <b>Does not make accurate 45° or 90° cuts</b> | <ol style="list-style-type: none"> <li>1. Stops not adjusted correctly</li> <li>2. Angle pointer not set accurately</li> <li>3. Miter gauge out of adjustment</li> </ol>   | <ol style="list-style-type: none"> <li>1. Check blade with square and adjust stops</li> <li>2. Check blade with square and adjust pointer</li> <li>3. Adjust miter gauge</li> </ol>  |
| <b>Material binds blade when ripping</b>      | <ol style="list-style-type: none"> <li>1. Fence not aligned with blade</li> <li>2. Warped wood</li> <li>3. Excessive feed rate</li> <li>4. Splitter not aligned with blade</li> </ol>  | <ol style="list-style-type: none"> <li>1. Check and adjust fence</li> <li>2. Select another piece of wood</li> <li>3. Reduce feed rate</li> <li>4. Align splitter with blade</li> </ol>  |
| <b>Saw makes unsatisfactory cuts</b>          | <ol style="list-style-type: none"> <li>1. Dull blade</li> <li>2. Blade mounted backwards</li> <li>3. Gum or pitch on blade</li> <li>4. Incorrect blade for cut</li> <li>5. Gum or pitch on table</li> </ol>  | <ol style="list-style-type: none"> <li>1. Sharpen or replace blade</li> <li>2. Turn blade around</li> <li>3. Remove blade and clean</li> <li>4. Change blade to correct type</li> <li>5. Clean table</li> </ol>  |
| <b>Blade does not come up to speed</b>        | <ol style="list-style-type: none"> <li>1. Extension cord too light or too long</li> <li>2. Low shop voltage</li> <li>3. Motor not wired for correct voltage</li> </ol>   | <ol style="list-style-type: none"> <li>1. Replace with adequate size cord</li> <li>2. Contact your local electric company</li> <li>3. Refer to motor junction box</li> </ol>   |
| <b>Saw vibrates excessively</b>               | <ol style="list-style-type: none"> <li>1. Stand on uneven floor</li> <li>2. Damaged saw blade</li> <li>3. Bad V-belts</li> <li>4. Bent pulley</li> <li>5. Improper motor mounting</li> <li>6. Loose hardware</li> </ol>  | <ol style="list-style-type: none"> <li>1. Reposition on flat, level surface</li> <li>2. Replace saw blade</li> <li>3. Replace V-belts</li> <li>4. Replace pulley</li> <li>5. Check and adjust motor</li> <li>6. Tighten hardware</li> </ol>  |
| <b>Rip fence binds on guide rails</b>         | <ol style="list-style-type: none"> <li>1. Guide rails or extension wing not installed correctly</li> <li>2. Guide of rip fence not adjusted properly</li> </ol>  | <ol style="list-style-type: none"> <li>1. Reassemble guide rails, refer to fence manual</li> <li>2. Adjust guides, refer to fence manual</li> </ol>  |
| <b>Material kicked back from blade</b>        | <ol style="list-style-type: none"> <li>1. Rip fence out of alignment</li> <li>2. Splitter not aligned with blade</li> <li>3. Feeding stock without rip fence</li> <li>4. Splitter not in place</li> <li>5. Dull blade</li> <li>6. Letting go of material before it is past blade</li> <li>7. Anti-kick back plates dull</li> </ol> | <ol style="list-style-type: none"> <li>1. Align rip fence with miter slot</li> <li>2. Align splitter with blade</li> <li>3. Install and use rip fence</li> <li>4. Install and use splitter (with guard)</li> <li>5. Replace blade</li> <li>6. Push material all the way past blade before releasing work</li> <li>7. Replace or sharpen anti-kick back plates</li> </ol> |
| <b>Blade does not raise or tilt freely</b>    | <ol style="list-style-type: none"> <li>1. Sawdust and debris in raising and tilting mechanisms</li> </ol>  | <ol style="list-style-type: none"> <li>1. Clean and regrease</li> </ol>  |

# Table and Cabinet Assembly – JTAS-10XL

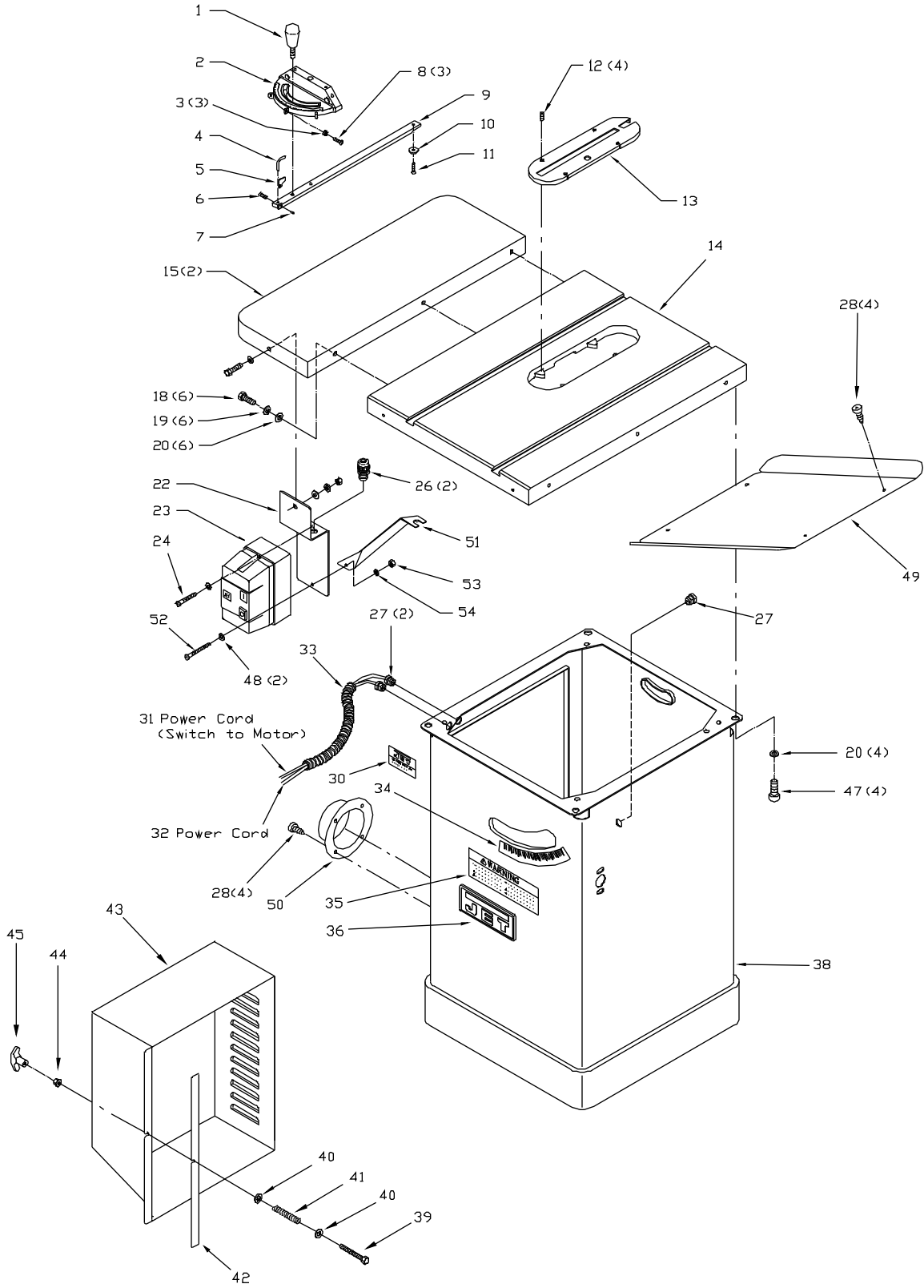



## Table and Cabinet Assembly – JTAS-10XL

| Index No. | Part No.     | Description                    | Size            | Qty. |
|-----------|--------------|--------------------------------|-----------------|------|
| 1         | JTAS10-1     | Lock Knob                      |                 | 1    |
| 2         | JTAS10-2     | Miter Gauge Body               |                 | 1    |
| 3         | TS-1540031   | Hex Nut                        | M5              | 3    |
| 4         | JTAS10-4     | Pointer                        |                 | 1    |
| 5         | JTAS10-5     | Stop Link                      |                 | 1    |
| 6         | TS-1521011   | Set Screw                      | M4x4            | 1    |
| 7         | JTAS10-7     | Special Pin                    | M3x6            | 1    |
| 8         | JTAS10-8     | Screw                          | M5x20           | 1    |
| 9         | JTAS10-9     | Guide Bar                      |                 | 1    |
| 10        | JTAS10-10    | Guide Washer                   |                 | 1    |
| 11        | JTAS10-11    | Flat Head Screw                | M6x8            | 1    |
|           | JTAS10-MG    | Miter Gauge Assembly (#1-11)   |                 | 1    |
| 12        | TS-0267041   | Set Screw                      | 1/4x3/8         | 4    |
| 13        | JTAS10L-13   | Table Insert                   |                 | 1    |
| 14        | JTAS10L-14W  | Table                          |                 | 1    |
| 15        | JTAS10-15W   | Extension Wing                 |                 | 2    |
| 18        | TS-0061051   | Hex Socket Cap Screw           | 7/16x1-1/2      | 6    |
| 19        | TS-0720101   | Lock Washer                    | 7/16            | 6    |
| 20        | TS-0680051   | Flat Washer                    | 7/16            | 10   |
| 22        | JTAS10-22W   | Switch Plate                   |                 | 1    |
| 23        | JTAS10-23    | Magnetic Switch                | 3HP, 230V, 1 Ph | 1    |
|           | JTAS10-23A   | Magnetic Switch                | 5HP, 230V, 3 Ph | 1    |
|           | JTAS10-23B   | Magnetic Switch                | 5HP, 460V, 3 Ph | 1    |
|           | JTAS12-23    | Magnetic Switch *              | 5HP, 1 Ph, 230V | 1    |
| 24        | JTAS10-24    | Screw                          | 3/16x3/4        | 1    |
| 26        | JTAS10-26    | Strain Relief Bushing          |                 | 2    |
| 27        | JTAS10-27    | Strain Relief Bushing          |                 | 3    |
|           | JTAS12-27    | Strain Relief Bushing *        |                 | 3    |
| 28        | JTAS10-28    | Tap Screw                      | M5x10           | 8    |
| 29        | JTAS10-29    | Cord Plate                     |                 | 1    |
|           | JTAS12-29    | Cord Plate *                   |                 | 1    |
| 30        | JTAS10L-30   | Identification Plate           |                 | 1    |
| 31        | JTAS10-31    | Power Cord (switch to motor)   |                 | 1    |
|           | JTAS12-31    | Power Cord (switch to motor) * |                 | 1    |
| 32        | JTAS10-32    | Power Cord                     |                 | 1    |
|           | JTAS12-32    | Power Cord *                   |                 | 1    |
| 33        | JTAS10-33    | Power Cord Sleeve              |                 | 1    |
|           | JTAS12-33    | Power Cord Sleeve *            |                 | 1    |
| 34        | JTAS10L-34   | Tilt Scale                     |                 | 1    |
| 35        | JTAS10-35    | Warning Label                  |                 | 1    |
| 36        | JTAS10L-36   | JET Label                      |                 | 1    |
| 38        | JTAS10L-38WA | Cabinet                        |                 | 1    |
| 39        | TS-1482101   | Hex Cap Bolt                   | M6x50           | 1    |
| 40        | TS-0680021   | Flat Washer                    | 1/4             | 2    |
| 41        | JTAS10-41    | Spring                         |                 | 1    |
| 42        | JTAS10-42    | Foam Strip                     |                 | 1    |
| 43        | JTAS10L-43W  | Motor Cover                    |                 | 1    |
| 44        | TS-1540021   | Hex Nut                        | M6              | 1    |
| 45        | JTAS10-45    | Handle                         |                 | 1    |
| 46        | JTAS10-47    | Cord Clamp Plate               |                 | 1    |
|           | JTAS12-47    | Cord Clamp Plate *             |                 | 1    |
| 47        | TS-0210011   | Hex Socket Cap Screw           | 7/16x3/4        | 4    |
| 48        | TS-0680011   | Flat Washer                    | 3/16            | 2    |

| <b>Index No.</b> | <b>Part No.</b> | <b>Description</b>        | <b>Size</b>   | <b>Qty.</b> |
|------------------|-----------------|---------------------------|---------------|-------------|
| 49.....          | JTAS10-50W..... | Lower Panel .....         |               | 1           |
| 50.....          | JTAS10-51 ..... | Dust Hose Adapter.....    |               | 1           |
| 51.....          | JTAS10-52W..... | Switch Brace Kit ** ..... |               | 1           |
| 52.....          | JTAS10-53 ..... | Screw .....               | 3/16 x 1..... | 1           |
| 53.....          | JTAS10-54 ..... | Nut.....                  | 3/16 .....    | 1           |
| 54.....          | JTAS10-55 ..... | Star Washer .....         | 3/16 .....    | 1           |

\* 10" saws with 5HP, 1Ph motor uses these parts.

\*\* Switch Brace kit contains bracket, screw, nut, star washer, and 8mm hex wrench.

# Blade Guard Assembly – JTAS-10XL

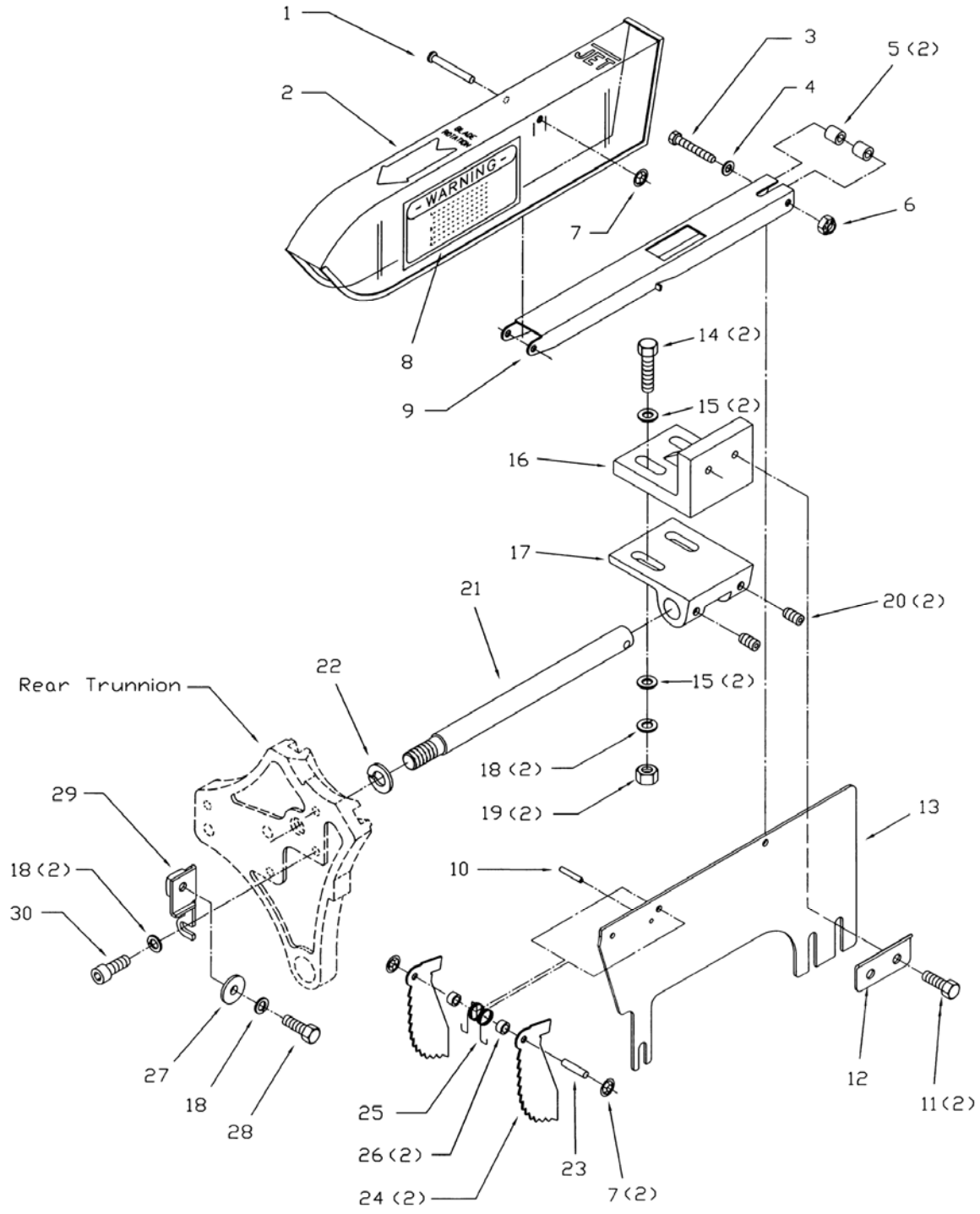

## Blade Guard Assembly – JTAS-10XL

| Index No. | Part No.    | Description                            | Size       | Qty. |
|-----------|-------------|--|------------|------|
|           | JTAS10L-BG  | Blade Guard Assembly (# 1-10/13/23-26) |            | 1    |
| 1         | JTAS10-G1   | Pin                                    |            | 1    |
| 2         | JTAS10L-G2  | Guard                                  |            | 1    |
| 3         | TS-0207091  | Hex Socket Cap Screw                   | 1/4x1-1/2  | 1    |
| 4         | TS-0680021  | Flat Washer                            | 1/4        | 1    |
| 5         | JTAS10-G5   | Spacer                                 |            | 2    |
| 6         | TS-0561011  | Hex Nut                                | 1/4        | 1    |
| 7         | JTAS10-G7   | Lock Grommet                           |            | 3    |
| 8         | JTAS10-G8   | Warning Label                          |            | 1    |
| 9         | JTAS10-G9   | Support Arm                            |            | 1    |
| 10        | JTAS10-G10  | Pin                                    |            | 1    |
| 11        | TS-0208061  | Hex Cap Bolt                           | 5/16x1     | 2    |
| 12        | JTAS10-G12  | Plate                                  |            | 1    |
| 13        | JTAS10-G13  | Splitter                               |            | 1    |
| 14        | TS-0051071  | Hex Cap Bolt                           | 5/16x1-1/2 | 2    |
| 15        | TS-0680031  | Flat Washer                            | 5/16       | 4    |
| 16        | JTAS10-G15  | Upper Blade Guard Bracket              |            | 1    |
| 17        | JTAS10-G16  | Lower Blade Guard Bracket              |            | 1    |
| 18        | TS-0720081  | Lock Washer                            | 5/16       | 5    |
| 19        | TS-0561021  | Hex Nut                                | 5/16       | 2    |
| 20        | TS-0270031  | Set Screw                              | 5/16x3/8   | 2    |
| 21        | JTAS10-G21A | Shaft                                  |            | 1    |
| 22        | TS-0720141  | Lock Washer                            | 5/8        | 1    |
| 23        | JTAS10-G23  | Pin                                    |            | 1    |
| 24        | JTAS10-G24  | Anti-Kickback Pawl                     |            | 2    |
| 25        | JTAS10-G25  | Spring                                 |            | 1    |
| 26        | JTAS10-G26  | Spacer                                 |            | 2    |
| 27        | TS-0680031  | Flat Washer                            | 5/16       | 1    |
| 28        | TS-0051021  | Hex Cap Bolt                           | 5/16x5/8   | 1    |
| 29        | JTAS10L-G29 | Bracket                                |            | 1    |
| 30        | TS-0208021  | Hex Socket Cap Screw                   | 5/16 x 1/2 | 2    |
|           | 477446      | 12mm Combination Wrench (not shown)    |            | 1    |

# Motor and Trunnion Assembly – JTAS-10XL

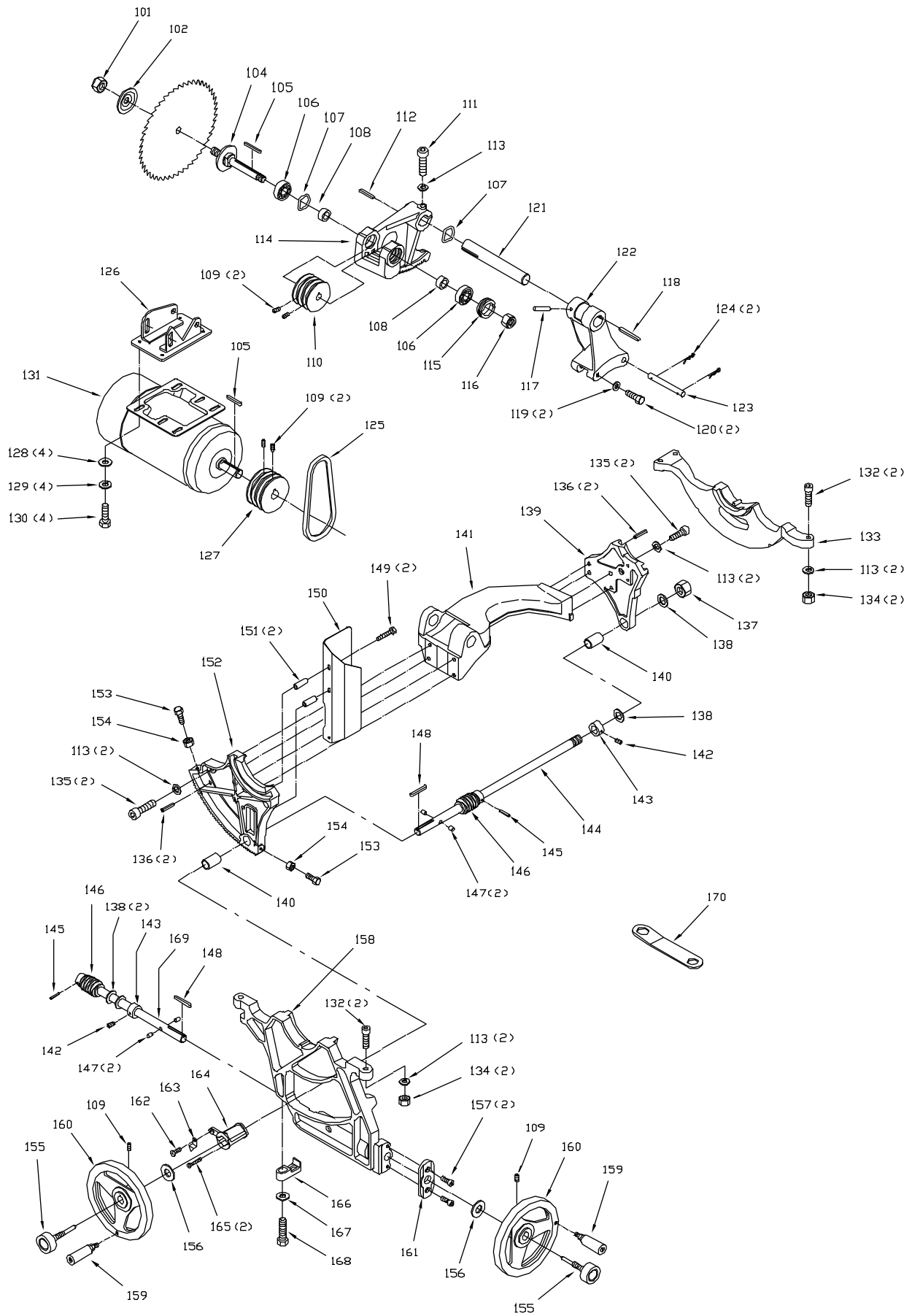

## Motor and Trunnion Assembly – JTAS-10XL

| Index No. | Part No.       | Description                             | Size           | Qty. |
|-----------|----------------|---|----------------|------|
| 101       | JTAS10L-101    | Arbor Nut                               |                | 1    |
| 102       | JTAS10-102     | Arbor Flange                            |                | 1    |
| 104       | JTAS10L-104    | Arbor with Flange                       |                | 1    |
| 105       | JTAS10-105     | Key                                     | M5x1-1/2       | 2    |
| 106       | BB-6203ZZ      | Ball Bearing                            |                | 2    |
| 107       | JTAS10-107     | Wave Washer                             |                | 2    |
| 108       | JTAS10-108     | Bearing Load Spacer                     |                | 2    |
| 109       | TS-0267041     | Set Screw                               | 1/4x3/8        | 6    |
| 110       | JTAS10-110     | Arbor Pulley                            |                | 1    |
| 111       | TS-0209031     | Hex Socket Cap Screw                    | 3/8x1-3/4      | 1    |
| 112       | JTAS10-112     | Key                                     | 1/4x50         | 1    |
| 113       | TS-0720091     | Lock Washer                             | 3/8            | 10   |
| 114       | JTAS10L-114    | Arbor Bracket                           |                | 1    |
| 115       | JTAS10-115     | Spanner Nut                             |                | 1    |
| 116       | JTAS10L-116    | Arbor Nut                               | 5/8            | 1    |
| 117       | JTAS10-117     | Spring Pin                              | M6x50          | 1    |
| 118       | JTAS10-118     | Key                                     | 1/4x75         | 1    |
| 119       | TS-0680051     | Flat Washer                             | 7/16           | 2    |
| 120       | TS-0091031     | Hex Cap Bolt                            | 7/16x1         | 2    |
| 121       | JTAS10-121     | Shaft                                   |                | 1    |
| 122       | JTAS10L-122    | Motor Bracket                           |                | 1    |
| 123       | JTAS10-123     | Pin                                     |                | 1    |
| 124       | JTAS10-124     | Spring Clip                             |                | 2    |
| 125       | VB-A23         | V-Belt                                  |                | 3    |
| 126       | JTAS10L-126    | Motor Mounting Bracket                  |                | 1    |
| 127       | JTAS10-127     | Motor Pulley                            |                | 1    |
| 128       | TS-0680031     | Flat Washer                             | 5/16           | 4    |
| 129       | TS-0720081     | Lock Washer                             | 5/16           | 4    |
| 130       | TS-0051031     | Hex Cap Bolt                            | 5/16x3/4       | 4    |
| 131       | JTAS10L-131N   | Motor (3HP, 1Ph, 230V only)             |                | 1    |
|           | JTAS10L-131C   | Motor (5HP, 1Ph, 230V only)             |                | 1    |
|           | JTAS10L-131A   | Motor (5HP, 3PH, 230/460V)              |                | 1    |
|           | JTAS10-131-017 | Centrifugal Switch Assembly (not shown) |                | 1    |
|           | JTAS10-131D    | Fan Cover (not shown)                   |                | 1    |
|           | JTAS10-131F    | Motor Fan (not shown)                   |                | 1    |
|           | C-600125       | Start Capacitor (not shown)             | 3HP, 1Ph motor | 1    |
|           | C-040250       | Run Capacitor (not shown)               | 3HP, 1Ph motor | 1    |
|           | JTAS10-1315B   | Start Capacitor (not shown)             | 5HP, 1Ph motor | 1    |
|           | JTAS10-1315A   | Run Capacitor (not shown)               | 5HP, 1Ph motor | 1    |
| 132       | TS-0209071     | Hex Socket Cap Screw                    | 3/8x1-1/2      | 5    |
| 133       | JTAS10L-133    | Rear Trunnion Bracket                   |                | 1    |
| 134       | TS-0561031     | Hex Nut                                 | 3/8            | 5    |
| 135       | TS-0209051     | Hex Socket Cap Screw                    | 3/8x1          | 4    |
| 136       | JTAS10-136     | Spring Pin                              | M8x25          | 4    |
| 137       | TS-0561081     | Hex Nut                                 | 3/4            | 1    |
| 138       | JTAS10-138     | Fiber Washer                            |                | 4    |
| 139       | JTAS10L-139    | Rear Trunnion                           |                | 1    |
| 140       | JTAS10-140     | Bushing                                 |                | 2    |
| 141       | JTAS10L-141    | Yoke                                    |                | 1    |
| 142       | TS-0270011     | Set Screw                               | 5/16x1/4       | 4    |
| 143       | JTAS10-143     | Collar                                  |                | 2    |
| 144       | JTAS10-144     | Shaft                                   |                | 1    |
| 145       | JTAS10-145     | Spring Pin                              | M5x30          | 2    |

| Index No. | Part No.    | Description                    | Size       | Qty. |
|-----------|-------------|--------------------------------|------------|------|
| 146       | JTAS10-146  | Worm                           |            | 2    |
| 147       | JTAS10-147  | Lock Pin                       |            | 4    |
| 148       | JTAS10-148  | Key                            | M5x35      | 2    |
| 149       | TS-0051071  | Hex Cap Bolt                   | 5/16x1-1/2 | 2    |
| 150       | JTAS10L-150 | Dust Deflector                 |            | 1    |
| 151       | JTAS10-151  | Spacer                         |            | 2    |
| 152       | JTAS10L-152 | Front Trunnion                 |            | 1    |
|           | JTAS10L-TA  | Trunnion Assy. (#113, 135-141) |            | 1    |
| 153       | TS-0051021  | Hex Cap Bolt                   | 5/16x5/8   | 2    |
| 154       | TS-0561021  | Hex Nut                        | 5/16       | 2    |
| 155       | JTAS10-155A | Lock Knob                      |            | 2    |
| 156       | JTAS10-156  | Fiber Washer                   |            | 2    |
| 157       | TS-0208061  | Hex Socket Cap Screw           | 5/16x1     | 2    |
| 158       | JTAS10L-158 | Front Trunnion Bracket         |            | 1    |
| 159       | JTAS10-159  | Hand Wheel Handle              |            | 2    |
| 160       | JTAS10-160  | Handwheel                      |            | 2    |
| 161       | JTAS10-161  | Shield Plate                   |            | 1    |
| 162       | JTAS10-162  | Round Head Screw               | 1/4x3/8    | 1    |
| 163       | JTAS10-163  | Pointer                        | 3/8        | 1    |
| 164       | JTAS10-164  | Pointer Bracket                |            | 1    |
| 165       | JTAS10-165  | Round Head Screw               | 3/16x2     | 2    |
| 166       | JTAS10-166  | Guide Block                    |            | 1    |
| 167       | TS-0680041  | Flat Washer                    | 3/8        | 1    |
| 168       | TS-0060071  | Hex Cap Bolt                   | 3/8x1-1/2  | 1    |
| 169       | JTAS10-169  | Tilt Shaft                     |            | 1    |
| 170       | JTAS10L-170 | Wrench                         |            | 1    |

# Table and Cabinet Assembly – JTAS-12XL

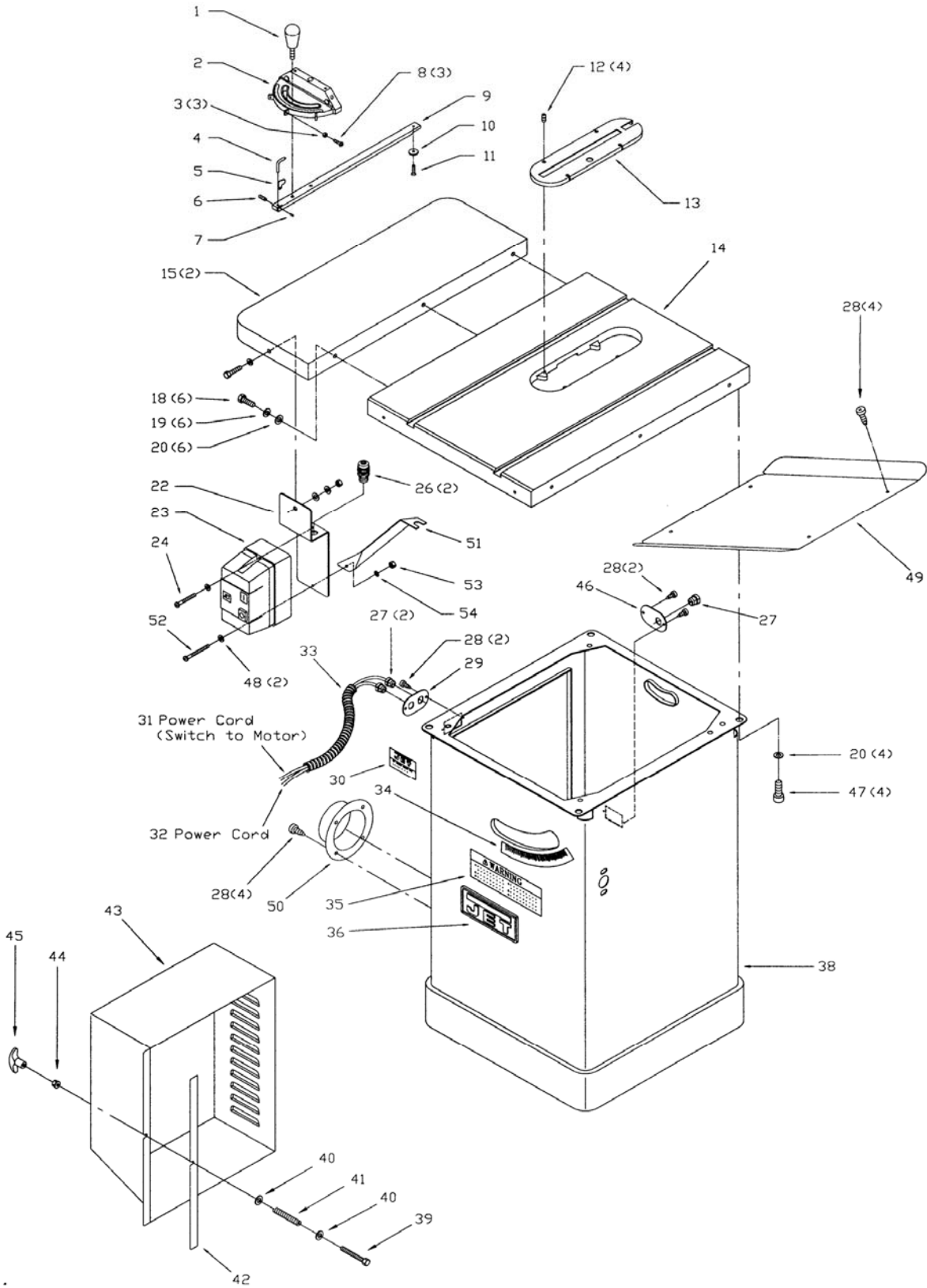



## Table and Cabinet Assembly – JTAS-12XL

| Index No. | Part No.    | Description                    | Size            | Qty. |
|-----------|-------------|--------------------------------|-----------------|------|
| 1         | JTAS10-1    | Lock Knob                      |                 | 1    |
| 2         | JTAS10-2    | Miter Gauge Body               |                 | 1    |
| 3         | TS-1540031  | Hex Nut                        | M5              | 3    |
| 4         | JTAS10-4    | Pointer                        |                 | 1    |
| 5         | JTAS10-5    | Stop Link                      |                 | 1    |
| 6         | TS-1521011  | Set Screw                      | M4x4            | 1    |
| 7         | JTAS10-7    | Special Pin                    | M3x6            | 1    |
| 8         | JTAS10-8    | Screw                          | M5x20           | 3    |
| 9         | JTAS10-9    | Guide Bar                      |                 | 1    |
| 10        | JTAS10-10   | Guide Washer                   |                 | 1    |
| 11        | JTAS10-11   | Flat Head Screw                | M6x8            | 1    |
|           | JTAS10-MG   | Miter Gauge Assembly (#1-11)   |                 | 1    |
| 12        | TS-0267041  | Set Screw                      | 1/4-20x3/8      | 4    |
| 13        | JTAS12L-13  | Table Insert                   |                 | 1    |
| 14        | JTAS12L-14W | Table                          |                 | 1    |
| 15        | JTAS12-15W  | Extension Wing                 |                 | 2    |
| 18        | TS-0061051  | Hex Cap Screw                  | 7/16-14x1-1/2   | 6    |
| 19        | TS-0720101  | Lock Washer                    | 7/16            | 6    |
| 20        | TS-0680051  | Flat Washer                    | 7/16            | 10   |
| 22        | JTAS10-22W  | Switch Plate                   |                 | 1    |
| 23        | JTAS10-23B  | Magnetic Switch                | 5HP, 460V, 3 Ph | 1    |
|           | JTAS12-23   | Magnetic Switch *              | 5HP, 230V, 1 Ph | 1    |
| 24        | TS-081C052  | Screw                          | #10-24x3/4      | 1    |
| 26        | JTAS10-26   | Strain Relief Bushing          |                 | 2    |
| 27        | JTAS10-27   | Strain Relief Bushing          |                 | 3    |
|           | JTAS12-27   | Strain Relief Bushing *        |                 | 3    |
| 28        | JTAS10-28   | Tap Screw                      | M5x10           | 12   |
| 29        | JTAS10-29   | Cord Plate                     |                 | 1    |
|           | JTAS12-29   | Cord Plate *                   |                 | 1    |
| 30        | JTAS12L-30  | Identification Plate           |                 | 1    |
| 31        | JTAS10-31   | Power Cord (switch to motor)   |                 | 1    |
|           | JTAS12-31   | Power Cord (switch to motor) * |                 | 1    |
| 32        | JTAS10-32   | Power Cord                     |                 | 1    |
|           | JTAS12-32   | Power Cord *                   |                 | 1    |
| 33        | JTAS10-33   | Power Cord Sleeve              |                 | 1    |
|           | JTAS12-33   | Power Cord Sleeve *            |                 | 1    |
| 34        | JTAS10L-34  | Tilt Scale                     |                 | 1    |
| 35        | JTAS10-35   | Warning Label                  |                 | 1    |
| 36        | JTAS10-36   | JET Label                      |                 | 1    |
| 38        | JTAS12L-38W | Cabinet                        |                 | 1    |
| 39        | TS-1482101  | Hex Cap Screw                  | M6x50           | 1    |
| 40        | TS-0680021  | Flat Washer                    | 1/4             | 2    |
| 41        | JTAS10-41   | Spring                         |                 | 1    |
| 42        | JTAS12L-42  | Foam Strip                     |                 | 1    |
| 43        | JTAS12L-43W | Motor Cover                    |                 | 1    |
| 44        | TS-1540041  | Hex Nut                        | M6              | 1    |
| 45        | JTAS10-45   | Handle                         |                 | 1    |
| 46        | JTAS10-47   | Cord Clamp Plate               |                 | 1    |
|           | JTAS12-47   | Cord Clamp Plate *             |                 | 1    |
| 47        | TS-0210011  | Socket Head Cap Screw          | 7/16-14x3/4     | 4    |
| 48        | TS-0680011  | Flat Washer                    | 3/16            | 2    |
| 49        | JTAS12-50W  | Lower Panel                    |                 | 1    |

| <b>Index No.</b> | <b>Part No.</b> | <b>Description</b>       | <b>Size</b>   | <b>Qty.</b> |
|------------------|-----------------|--------------------------|---------------|-------------|
| 50.....          | JTAS10-51W..... | Dust Hose Adapter.....   |               | 1           |
| 51.....          | JTAS12-52W..... | Switch Brace Kit **..... |               | 1           |
| 52.....          | TS-081C062..... | Screw.....               | #10-24x1..... | 1           |
| 53.....          | TS-0560071..... | Nut.....                 | #10-24.....   | 3           |
| 54.....          | TS-0733031..... | Star Washer.....         | #10.....      | 1           |

\* Saws with 5HP, 1Ph motor use these parts.

\*\* Switch Brace kit contains bracket, screw, nut, star washer, and 8mm hex wrench.

# Blade Guard Assembly – JTAS-12XL

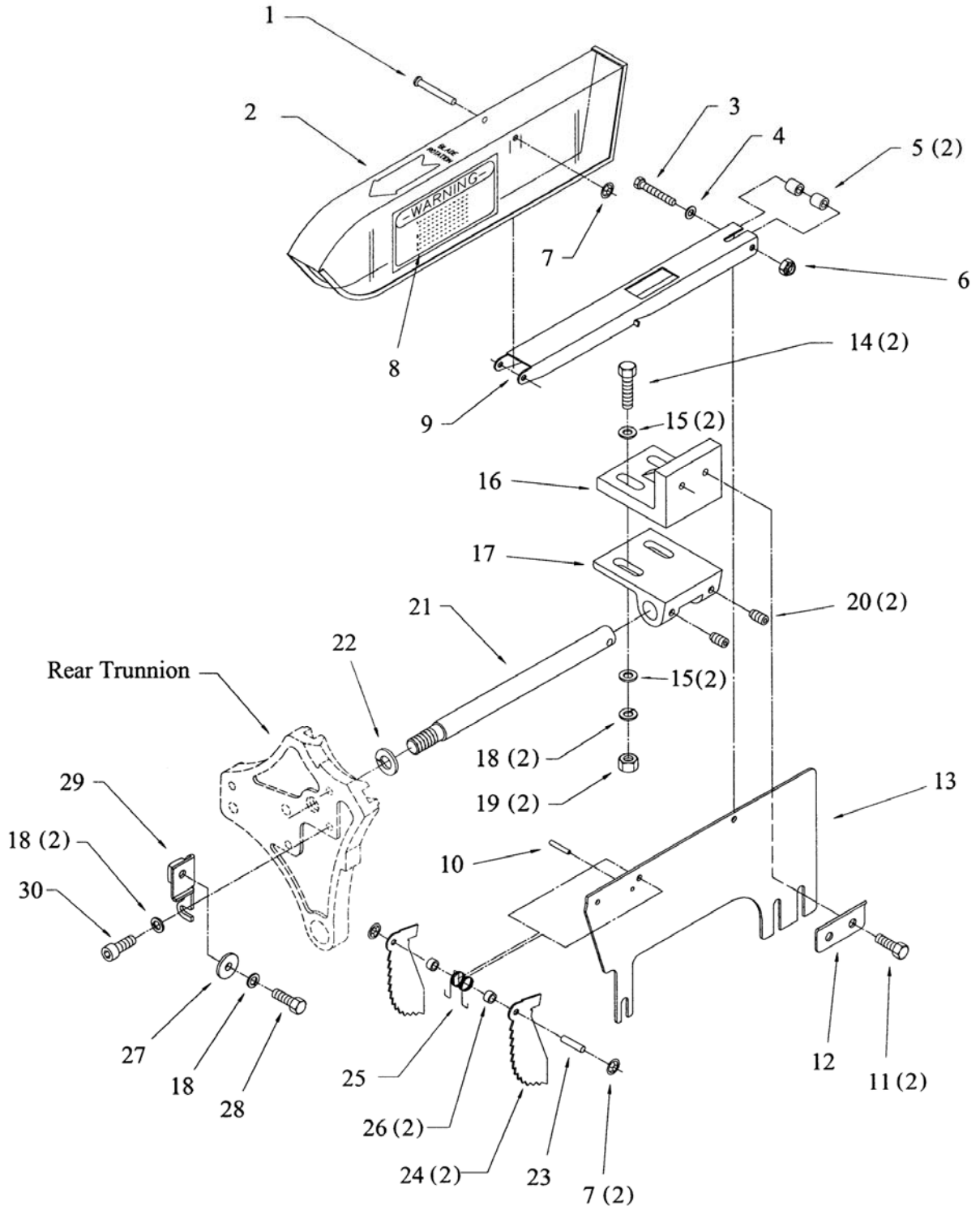

## Blade Guard Assembly – JTAS-12XL

| Index No. | Part No.    | Description                              | Size          | Qty. |
|-----------|-------------|--|---------------|------|
|           | JTAS12L-BG  | Blade Guard Assembly (# 1-10, 13, 23-26) |               | 1    |
| 1         | JTAS10-G1   | Pin                                      |               | 1    |
| 2         | JTAS12L-G2  | Guard                                    |               | 1    |
| 3         | TS-0207081  | Socket Head Cap Screw                    | 1/4-20x1-1/2  | 1    |
| 4         | TS-0680021  | Flat Washer                              | 1/4           | 1    |
| 5         | JTAS10-G5   | Spacer                                   |               | 2    |
| 6         | TS-0561011  | Hex Nut                                  | 1/4-20        | 1    |
| 7         | JTAS10-G7   | Lock Grommet                             |               | 3    |
| 8         | JTAS10-G8   | Warning Label                            |               | 1    |
| 9         | JTAS12-G9   | Support Arm                              |               | 1    |
| 10        | JTAS10-G10  | Pin                                      |               | 1    |
| 11        | TS-0051051  | Hex Cap Screw                            | 5/16-18x1     | 2    |
| 12        | JTAS10-G12  | Plate                                    |               | 1    |
| 13        | JTAS12-G13  | Splitter                                 |               | 1    |
| 14        | TS-0051071  | Hex Cap Screw                            | 5/16-18x1-1/2 | 2    |
| 15        | TS-0680031  | Flat Washer                              | 5/16          | 4    |
| 16        | JTAS10-G16  | Upper Blade Guard Bracket                |               | 1    |
| 17        | JTAS10-G17  | Lower Blade Guard Bracket                |               | 1    |
| 18        | TS-0720081  | Lock Washer                              | 5/16          | 5    |
| 19        | TS-0561021  | Hex Nut                                  | 5/16-18       | 2    |
| 20        | TS-0270031  | Set Screw                                | 5/16-18x3/8   | 2    |
| 21        | JTAS10-G21A | Shaft                                    |               | 1    |
| 22        | TS-0720131  | Lock Washer                              | 5/8           | 1    |
| 23        | JTAS10-G23  | Pin                                      |               | 1    |
| 24        | JTAS12-G24  | Anti-Kickback Pawl                       |               | 2    |
| 25        | JTAS10-G25  | Spring                                   |               | 1    |
| 26        | JTAS10-G26  | Spacer                                   |               | 2    |
| 27        | TS-0680031  | Flat Washer                              | 5/16          | 1    |
| 28        | TS-0051021  | Hex Cap Screw                            | 5/16-18x5/8   | 1    |
| 29        | JTAS10L-G29 | Bracket                                  |               | 1    |
| 30        | TS-0208021  | Socket Head Cap Screw                    | 5/16-18x1/2   | 2    |
|           | 477446      | 12mm Combination Wrench (not shown)      |               | 1    |

# Motor and Trunnion Assembly – JTAS-12XL

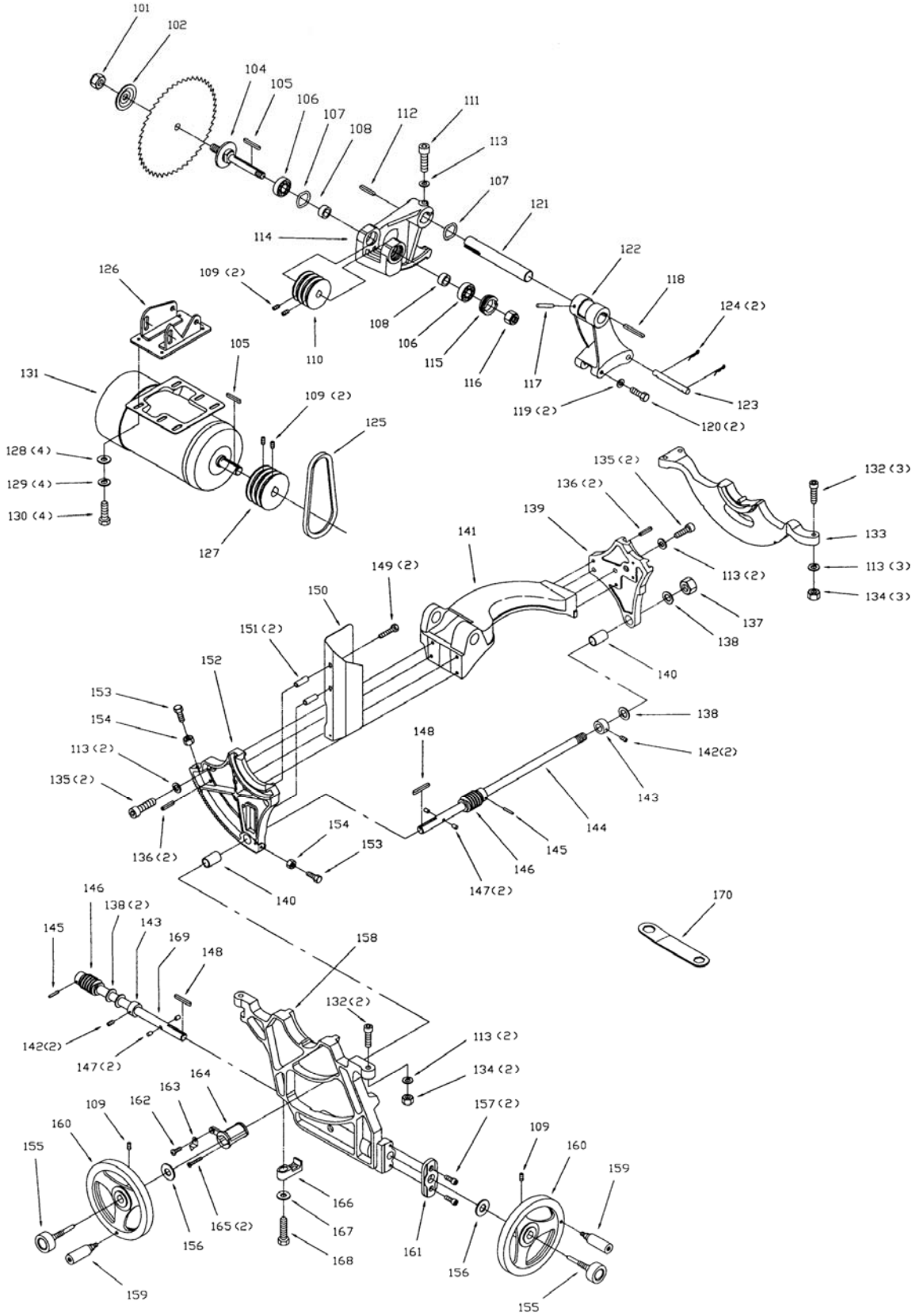

## Motor and Trunnion Assembly – JTAS-12XL

| Index No. | Part No.     | Description                    | Size          | Qty. |
|-----------|--------------|--------------------------------|---------------|------|
| 101       | JTAS12L-101  | Arbor Nut                      |               | 1    |
| 102       | JTAS12-102   | Arbor Flange                   |               | 1    |
| 104       | JTAS12L-104  | Arbor with Flange              |               | 1    |
| 105       | JTAS12-105   | Key                            | M5x1-1/2      | 2    |
| 106       | BB-6005ZZ    | Ball Bearing                   | 6005ZZ        | 2    |
| 107       | JTAS10-107   | Wave Washer                    |               | 2    |
| 108       | JTAS12-108   | Bearing Load Spacer            |               | 2    |
| 109       | TS-0267041   | Set Screw                      | 1/4-20x3/8    | 6    |
| 110       | JTAS12-110   | Arbor Pulley                   |               | 1    |
| 111       | TS-0209081   | Hex Socket Cap Screw           | 3/8-16x1-3/4  | 1    |
| 112       | JTAS10-112   | Key                            | 1/4x50        | 1    |
| 113       | TS-0720091   | Lock Washer                    | 3/8           | 10   |
| 114       | JTAS12L-114  | Arbor Bracket                  |               | 1    |
| 115       | JTAS12-115   | Spanner Nut                    |               | 1    |
| 116       | TS-0561081   | Hex Nut                        | 3/4-10        | 1    |
| 117       | JTAS10-117   | Spring Pin                     | M6x50         | 1    |
| 118       | JTAS10-118   | Key                            | 1/4x75        | 1    |
| 119       | TS-0680051   | Flat Washer                    | 7/16          | 2    |
| 120       | TS-0091031   | Hex Cap Screw                  | 7/16-14x1     | 2    |
| 121       | JTAS10-121   | Shaft                          |               | 1    |
| 122       | JTAS10L-122  | Motor Bracket                  |               | 1    |
| 123       | JTAS10-123   | Pin                            |               | 1    |
| 124       | JTAS10-124   | Spring Clip                    |               | 2    |
| 125       | VB-A23       | V-Belt                         | A-23          | 3    |
| 126       | JTAS10L-126  | Motor Mount                    |               | 1    |
| 127       | JTAS10-127   | Motor Pulley                   |               | 1    |
| 128       | TS-0680031   | Flat Washer                    | 5/16          | 4    |
| 129       | TS-0720081   | Lock Washer                    | 5/16          | 4    |
| 130       | TS-0051031   | Hex Cap Screw                  | 5/16-18x3/4   | 4    |
| 131       | JTAS12L-131  | Motor (5HP, 1Ph, 230V only)    |               | 1    |
|           | JTAS10L-131A | Motor (5HP, 3Ph, 230/460V)     |               | 1    |
|           | JTAS10-1315B | Starting Capacitor (not shown) | 5HP, 1Ph      | 1    |
|           | JTAS10-1315A | Running Capacitor (not shown)  | 5HP, 1Ph      | 1    |
| 132       | TS-0209071   | Socket Head Cap Screw          | 3/8-16x1-1/2  | 5    |
| 133       | JTAS10L-133  | Rear Trunnion Bracket          |               | 1    |
| 134       | TS-0561031   | Hex Nut                        | 3/8-16        | 5    |
| 135       | TS-0209051   | Socket Head Cap Screw          | 3/8-16x1      | 4    |
| 136       | JTAS10-136   | Spring Pin                     | M8x25         | 4    |
| 137       | TS-0561081   | Hex Nut                        | 3/4-10        | 1    |
| 138       | JTAS10-138   | Fiber Washer                   |               | 4    |
| 139       | JTAS10L-139  | Rear Trunnion                  |               | 1    |
| 140       | JTAS10-140   | Bushing                        |               | 2    |
| 141       | JTAS12L-141  | Yoke                           |               | 1    |
| 142       | TS-0270011   | Set Screw                      | 5/16-18x1/4   | 4    |
| 143       | JTAS10-143   | Collar                         |               | 2    |
| 144       | JTAS12-144   | Shaft                          |               | 1    |
| 145       | JTAS10-145   | Spring Pin                     | M5x30         | 2    |
| 146       | JTAS10-146   | Worm                           |               | 2    |
| 147       | JTAS10-147   | Lock Pin                       |               | 4    |
| 148       | JTAS10-148   | Key                            | M5x35         | 2    |
| 149       | JTAS12-149   | Hex Cap Screw                  | 5/16-18x1-1/2 | 2    |
| 150       | JTAS12L-150  | Dust Deflector                 |               | 1    |

| Index No. | Part No.    | Description            | Size         | Qty. |
|-----------|-------------|------------------------|--------------|------|
| 151       | JTAS10-151  | Spacer                 |              | 2    |
| 152       | JTAS10L-152 | Front Trunnion         |              | 1    |
| 153       | TS-0051021  | Hex Cap Screw          | 5/16-18x5/8  | 2    |
| 154       | TS-0561021  | Hex Nut                | 5/16-18      | 2    |
| 155       | JTAS12L-155 | Lock Knob              |              | 2    |
| 156       | JTAS10-156  | Fiber Washer           |              | 2    |
| 157       | TS-0208101  | Socket Head Cap Screw  | 5/16-18x2    | 2    |
| 158       | JTAS12L-158 | Front Trunnion Bracket |              | 1    |
| 159       | JTAS10L-159 | Hand Wheel Handle      |              | 2    |
| 160       | JTAS10L-160 | Hand Wheel             |              | 2    |
| 161       | JTAS12-161  | Adapter                |              | 1    |
| 162       | TS-0813022  | Round Head Screw       | 1/4-20x3/8   | 1    |
| 163       | JTAS10-163  | Pointer                |              | 1    |
| 164       | JTAS10-164  | Pointer Bracket        |              | 1    |
| 165       | TS-081C102  | Pan Head Screw         | #10-24x2     | 2    |
| 166       | JTAS10-166  | Guide Block            |              | 1    |
| 167       | TS-0680041  | Flat Washer            | 3/8          | 1    |
| 168       | TS-0060071  | Hex Cap Screw          | 3/8-16x1-1/2 | 1    |
| 169       | JTAS12-169  | Tilt Shaft             |              | 1    |
| 170       | JTAS12-170  | Wrench                 |              | 1    |

# Electrical Schematic - Single Phase

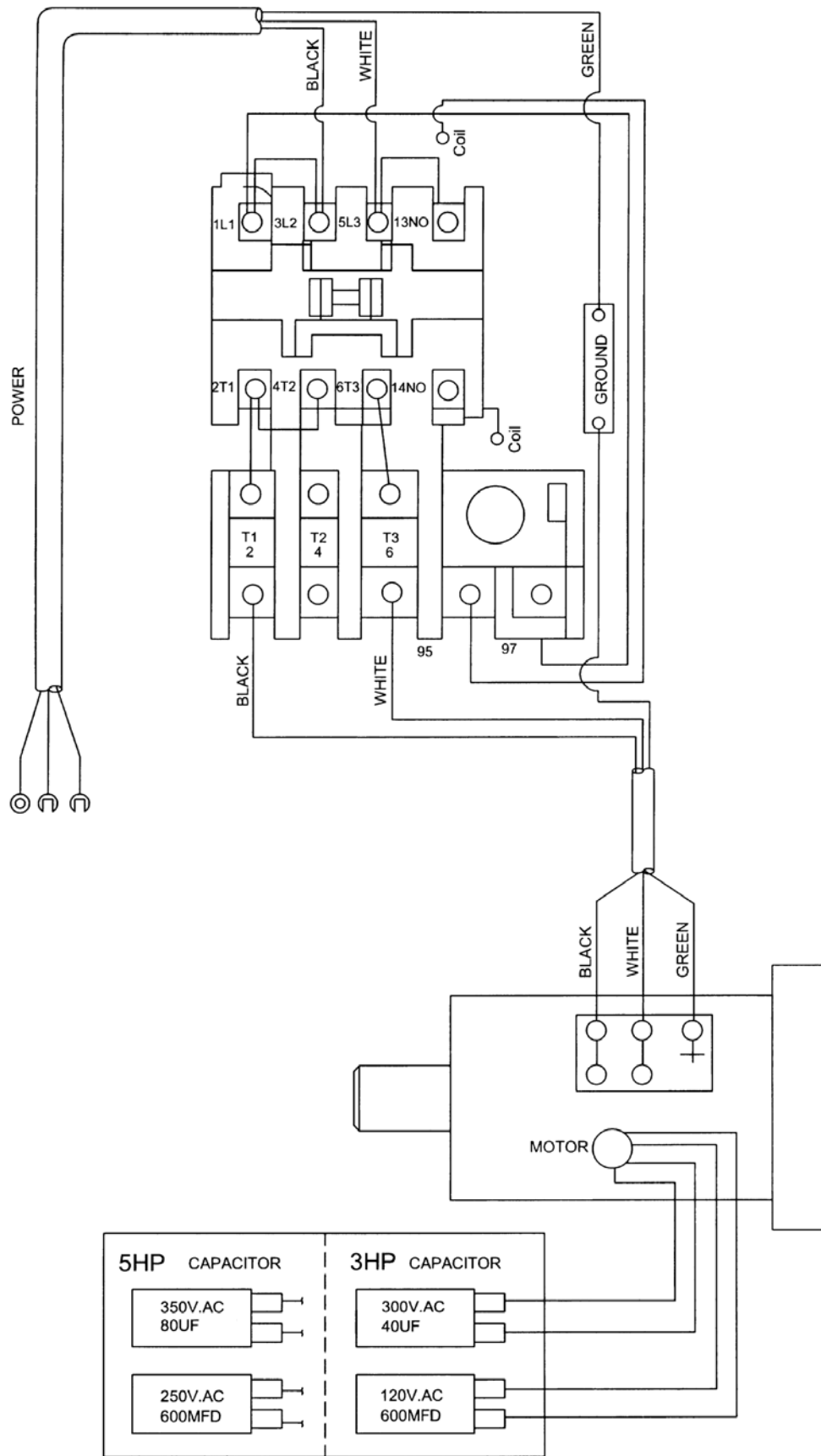



# Electrical Schematic - Three Phase

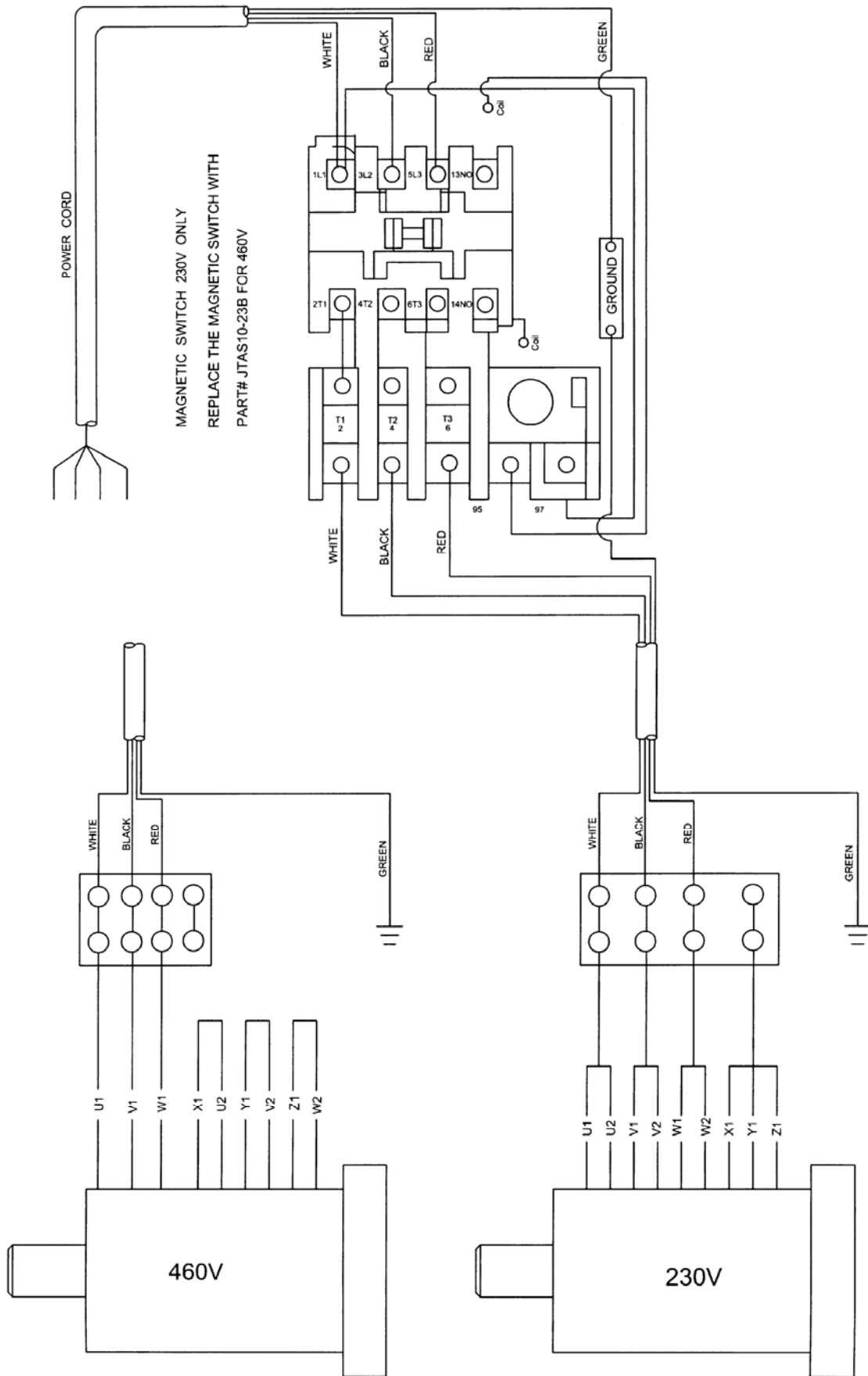

## NOTES





**WALTER MEIER (Manufacturing) Inc.**

427 New Sanford Road  
LaVergne, Tennessee 37086  
Phone: 800-274-6848  
[www.waltermeier.com](http://www.waltermeier.com)