

Type:  
Part no.:

MSf 680D (60Hz,110V)  
72204513118



Item	Part no.	Designation	Quantity	Price RPR	AT	Country
0010	31903156012	MOTOR HOUSING ASS.	1	on req.	-	-
0020	30712076012	Brush holder	2	on req.	-	-
0030	30711098009	CARBON BRUSH	2	on req.	-	-
0040	43046001002	SHEET METAL SCREW	2	on req.	-	-
0050	51256001111	FIELD WITH WINDING	1	on req.	-	-
0080	43046035008	SHEET METAL SCREW	2	on req.	-	-
0090	32427066000	COVER	2	on req.	-	-
0100	43046020001	SHEET METAL SCREW	2	on req.	-	-
0110	53256001113	ARMATURE	1	on req.	X	-
0150	31428042004	AIR CONDUCTING RING	1	on req.	-	-
0160	31206087005	GEAR HOUSING	1	on req.	-	-
0165	31206087014	Gear housing ass.	1	on req.	-	-
0170	42004039001	HEXAGON NUT	1	on req.	-	-
0185	33809165013	BEVEL GEARS	1	on req.	-	-
0190	32408293002	DISC	1	on req.	-	-
0200	41701213096	GROOVED BALL BEARING	1	on req.	-	-
0210	32411058001	COVERING DISC	1	on req.	-	-
0220	30601050002	FELT RING	1	on req.	-	-
0230	32416082005	COVER PLATE	1	on req.	-	-
0240	43064003047	FILLISTER HEAD SCREW	3	on req.	-	-
0260	32419089009	Plate	1	on req.	-	-
0270	30601098001	FELT RING	1	on req.	-	-
0280	32411074000	COVERING DISC	1	on req.	-	-
0290	41701224024	GROOVE BALL BEARING	1	on req.	-	-
0300	32416078007	COVER PLATE	1	on req.	-	-
0310	43064003047	FILLISTER HEAD SCREW	3	on req.	-	-
0330	33406161000	DRIVING SHAFT	1	on req.	-	-
0340	42615108003	Retainer ring	1	on req.	-	-
0350	41706030007	NEEDLE BEARING	1	on req.	-	-
0360	32624104024	WASHER	1	on req.	-	-
0360	32624104030	WASHER	1	on req.	-	-
0370	43064015054	HEX. HEAD CAP SCREW	4	on req.	-	-
0380	41701210021	Groove ball bearing	1	on req.	-	-
0381	42628001006	CIRCLIP RING	1	on req.	-	-
0390	30507174003	BUSH	1	on req.	-	-
0400	43033015052	FILLISTER HEAD SCREW	4	on req.	-	-
0410	43033017059	FILLISTER HEAD SCREW	4	on req.	-	-
0411	42443004057	LOCKING WASHER	8	on req.	-	-
0440	31204124003	Handle upper part	1	on req.	-	-
0450	31204123005	Handle lower part	1	on req.	-	-
0460	30722134011	INTERFER. CAPACITOR	1	on req.	-	-
0470	30701117009	SWITCH	1	on req.	-	-
0480	43046016003	SHEET METAL SCREW	2	on req.	-	-
0490	32431033003	CLAMPING PIECE	1	on req.	-	-
0500	43046021000	SHEET METAL SCREW	2	on req.	-	-
0515	30707185013	CABLE ASS.	1	on req.	-	-
0520	31413094007	Protecting sleeve	1	on req.	-	-
5000	63801120006	INNER FLANGE	1	on req.	-	-
5010	63802052000	OUTER FLANGE	1	on req.	-	-
5020	32119117015	Anti-vibrations handle	1	on req.	-	-
5030	31810070016	WHEEL GUARD ASS	1	on req.	-	-
5040	62903011005	SINGLE HEAD WRENCH	1	on req.	-	-
5050	62907004005	SOCKET HEAD WRENCH	1	on req.	-	-
5060	62910022002	TWO-PIN PEG SPANNER	1	on req.	-	-

<b>Item</b>	<b>Part no.</b>	<b>Designation</b>	<b>Quantity</b>	<b>Price RPR</b>	<b>AT</b>	<b>Country</b>
6000	32160003135	TUBE OF GREASE	1	on req.	-	-
9000	34100613067	Operat.instruction	1	on req.	-	-

Type:  
Part no.:

MSf 680D (60Hz,110V)  
72204513118

7 220 45 - MSF 680d  
7 220 46 - MSF 680c  
7 220 49 - MSFa 680d  
7 220 50 - MSFa 680c

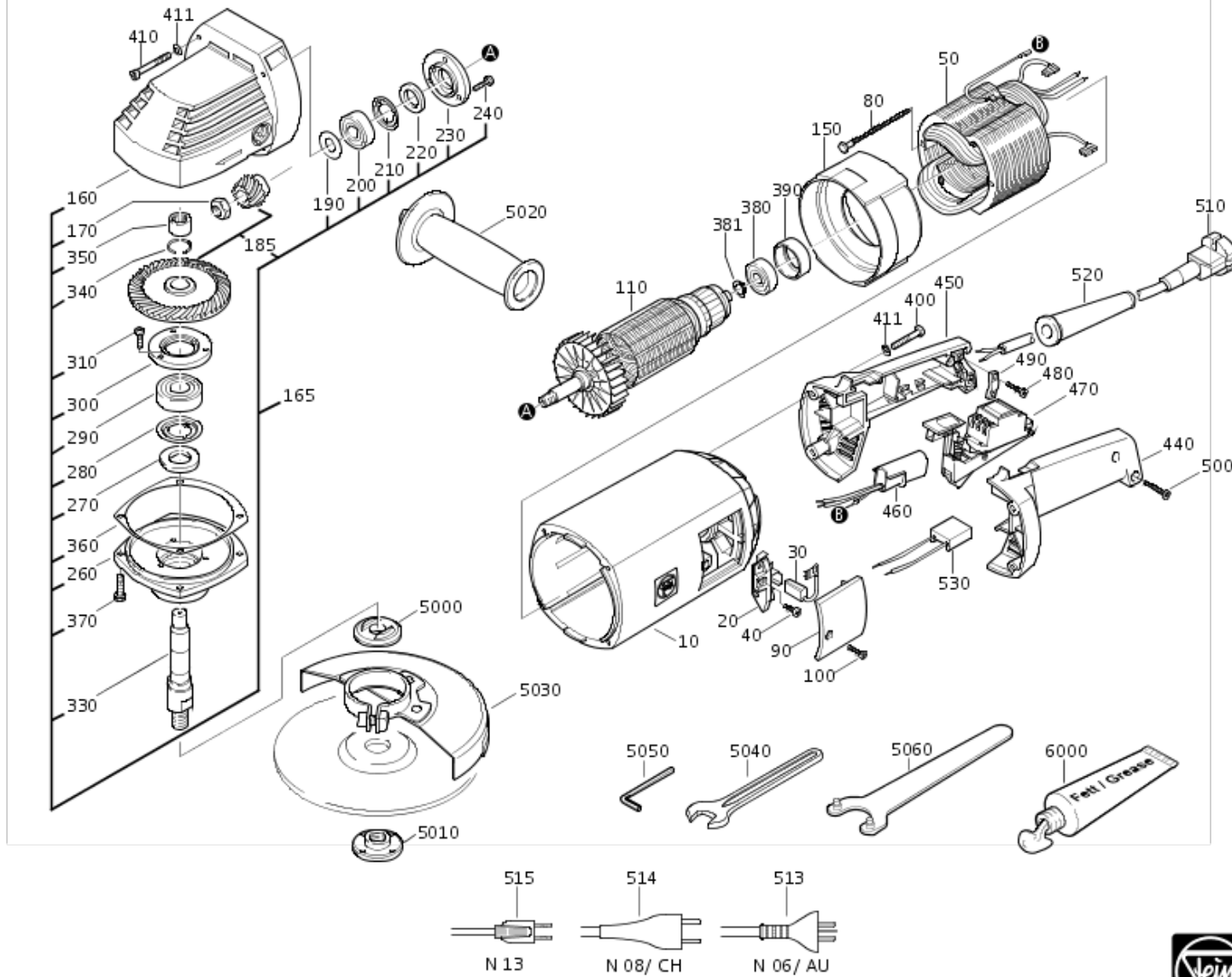

Powered by innovation

