

Prior to Jan 2011

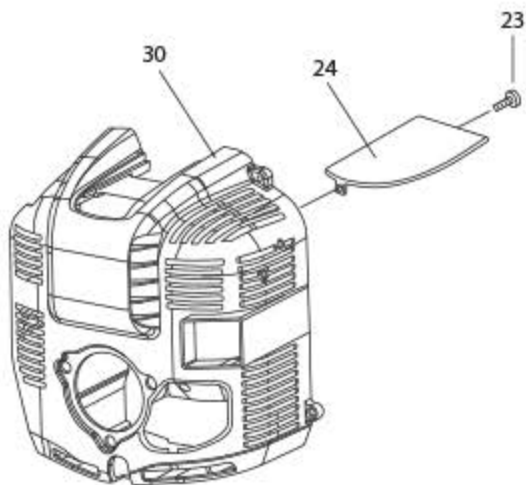

Implemented Jan 2011

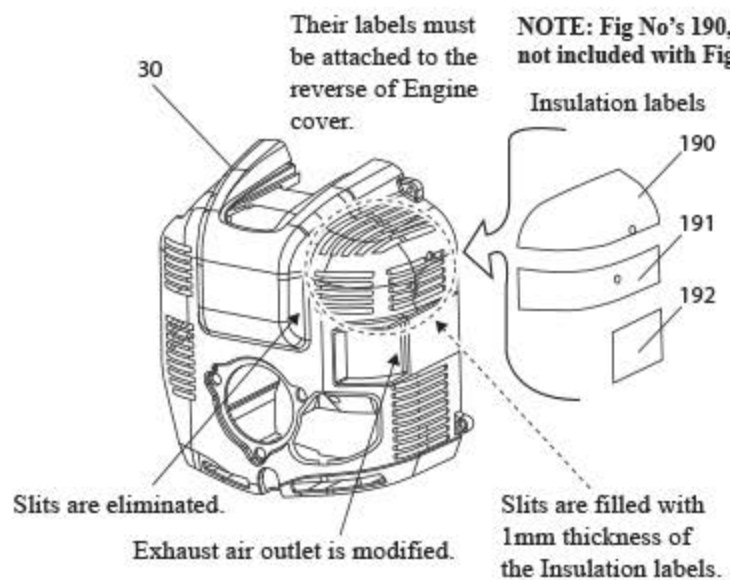

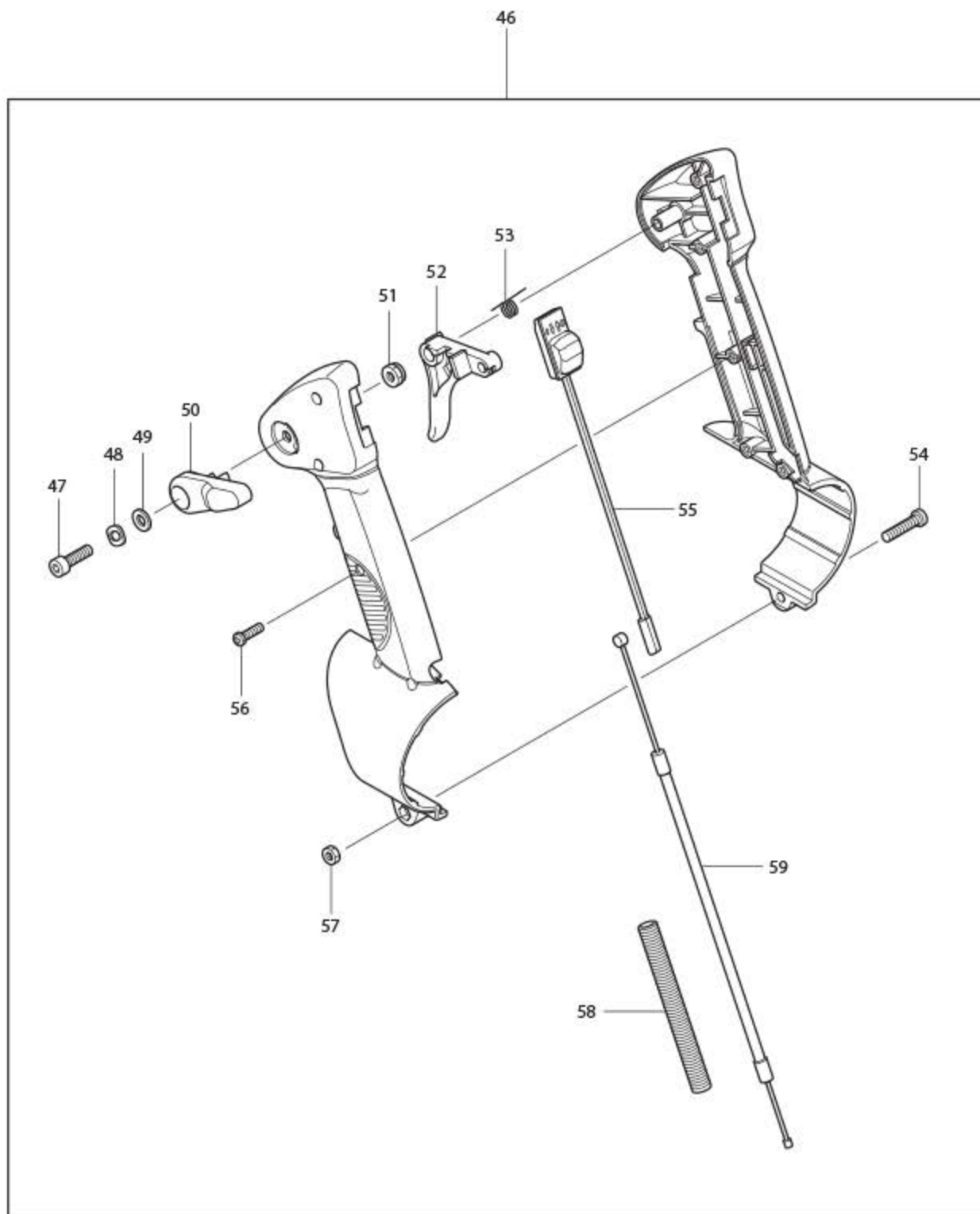

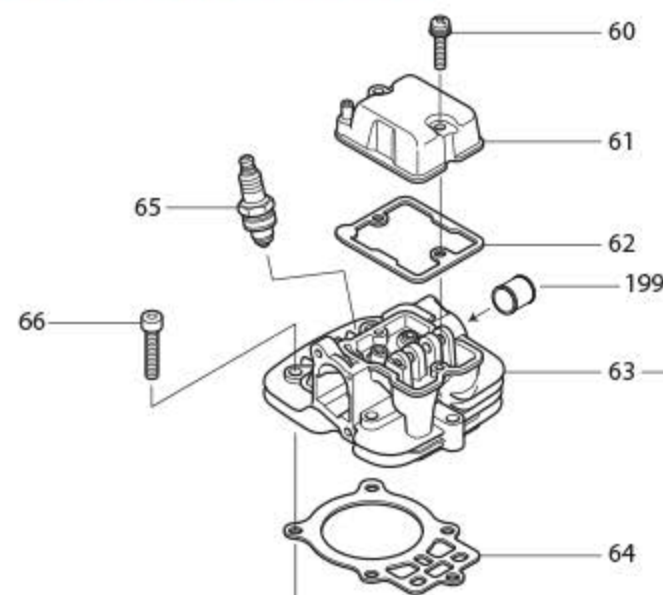

NOTICE: 199 with **TYPE 2** cylinder head only.

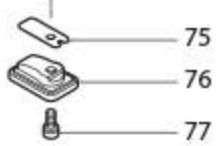
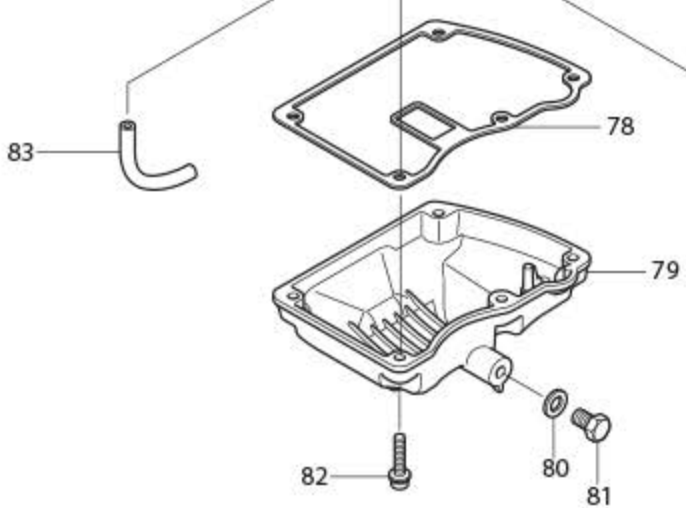
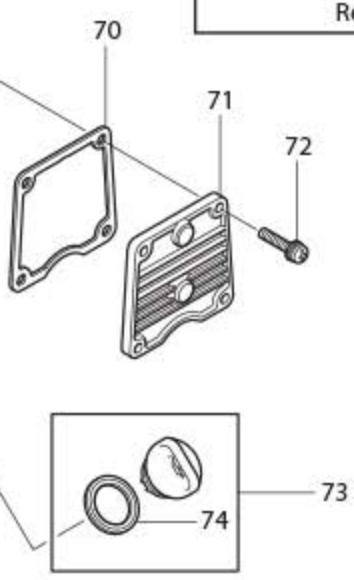
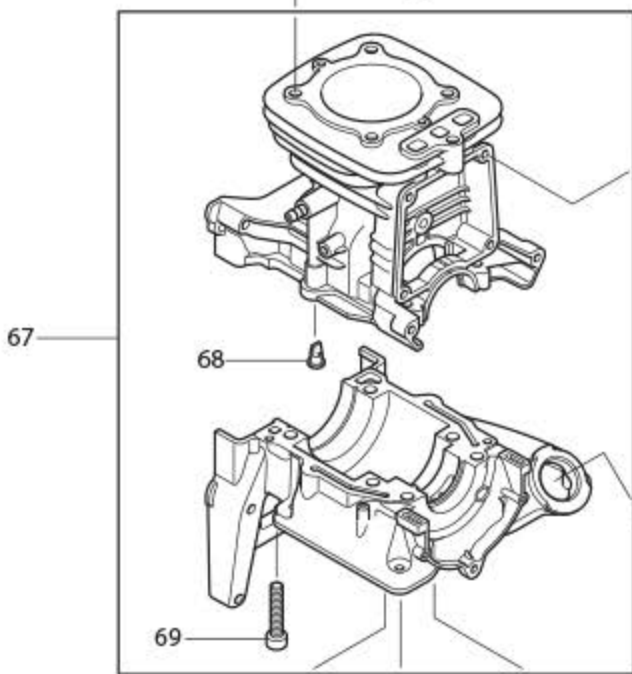
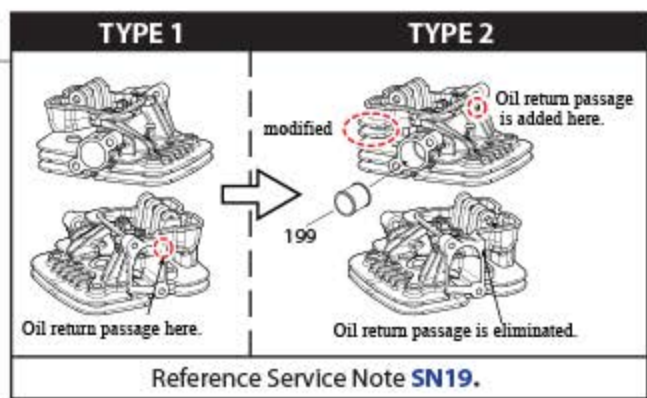

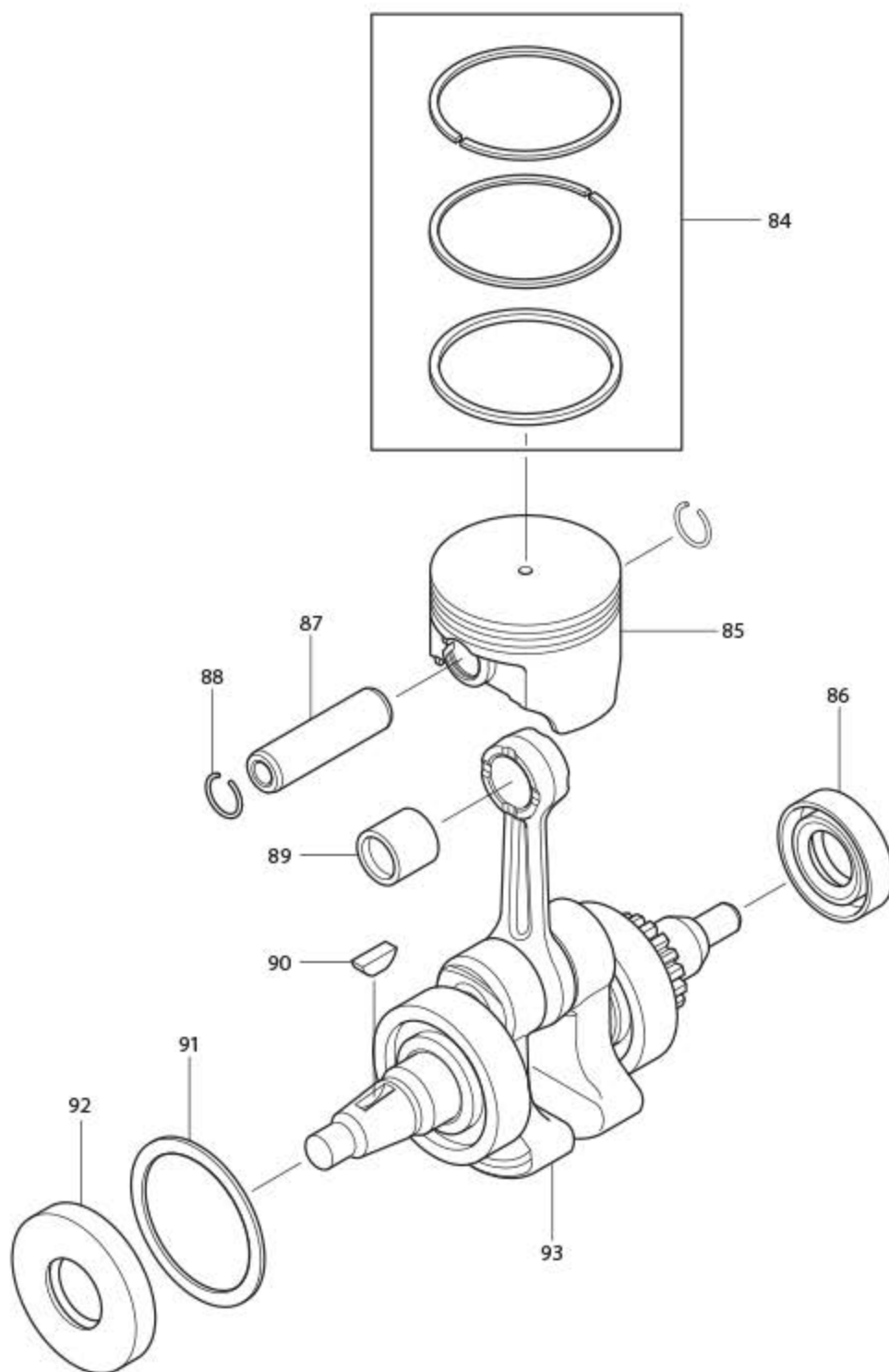

The following parts have changed. (Interchangeable as a set)

Reference Service Note [SN2012_13](#) on how to install.

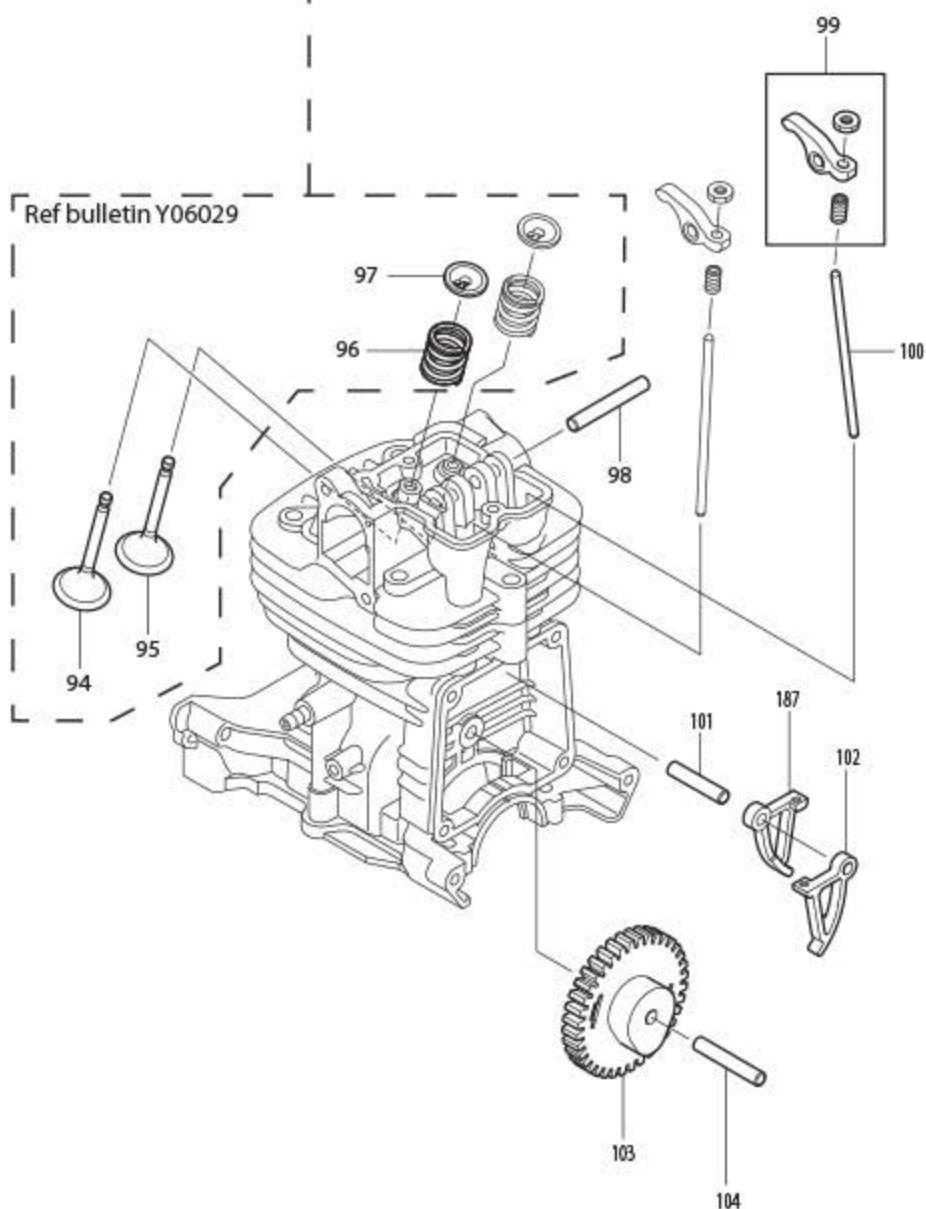
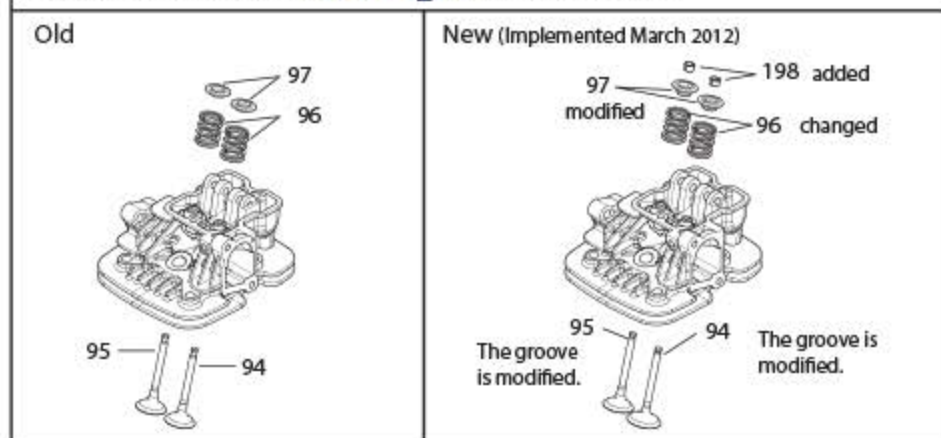

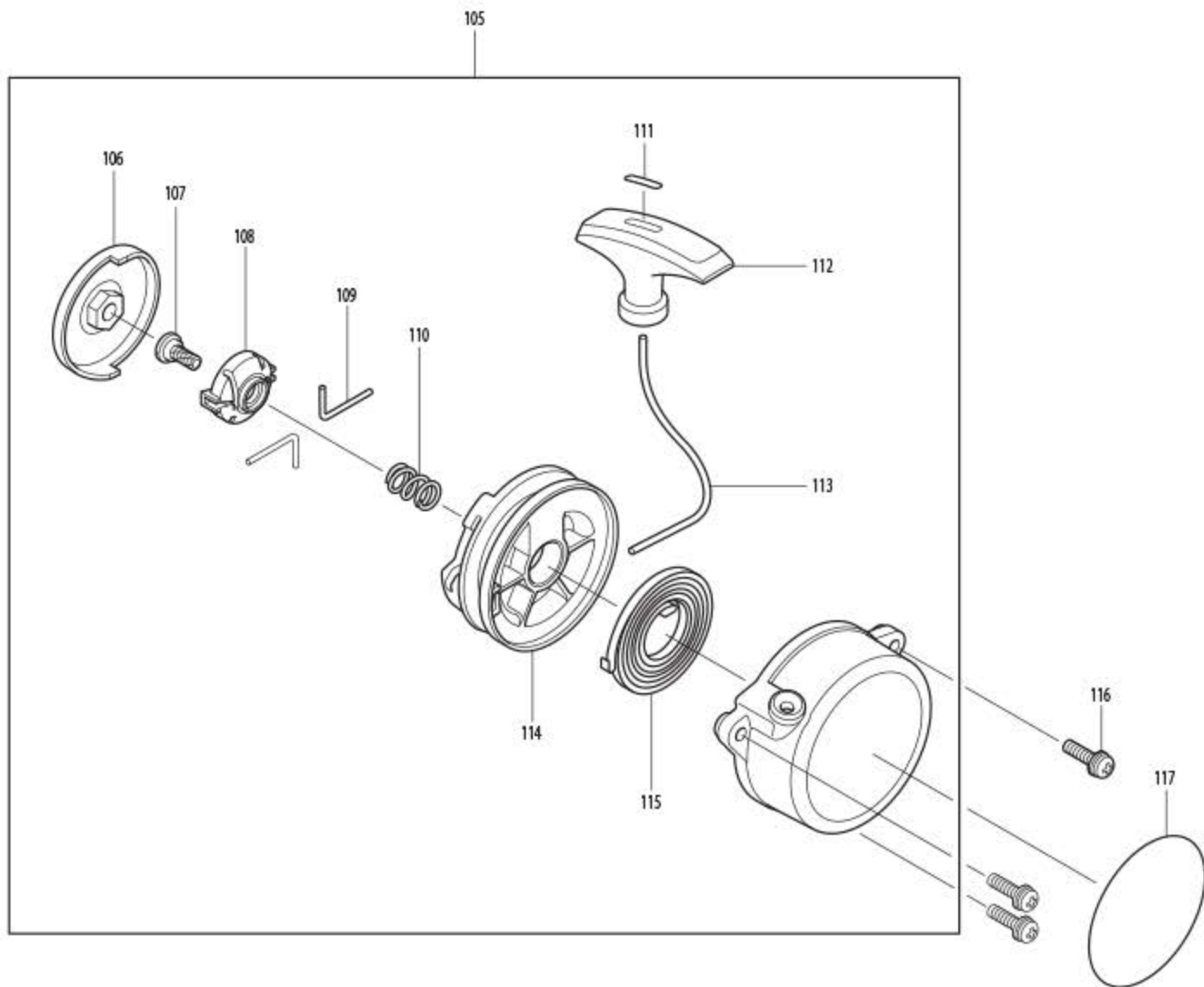

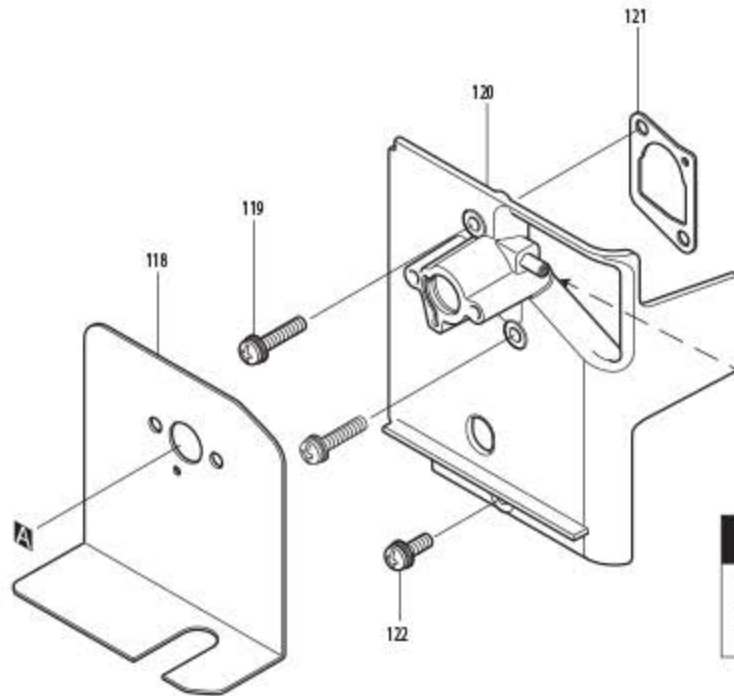

TYPE 2 Cylinder Head
NOTICE: Do not connect tube to port on insulator.

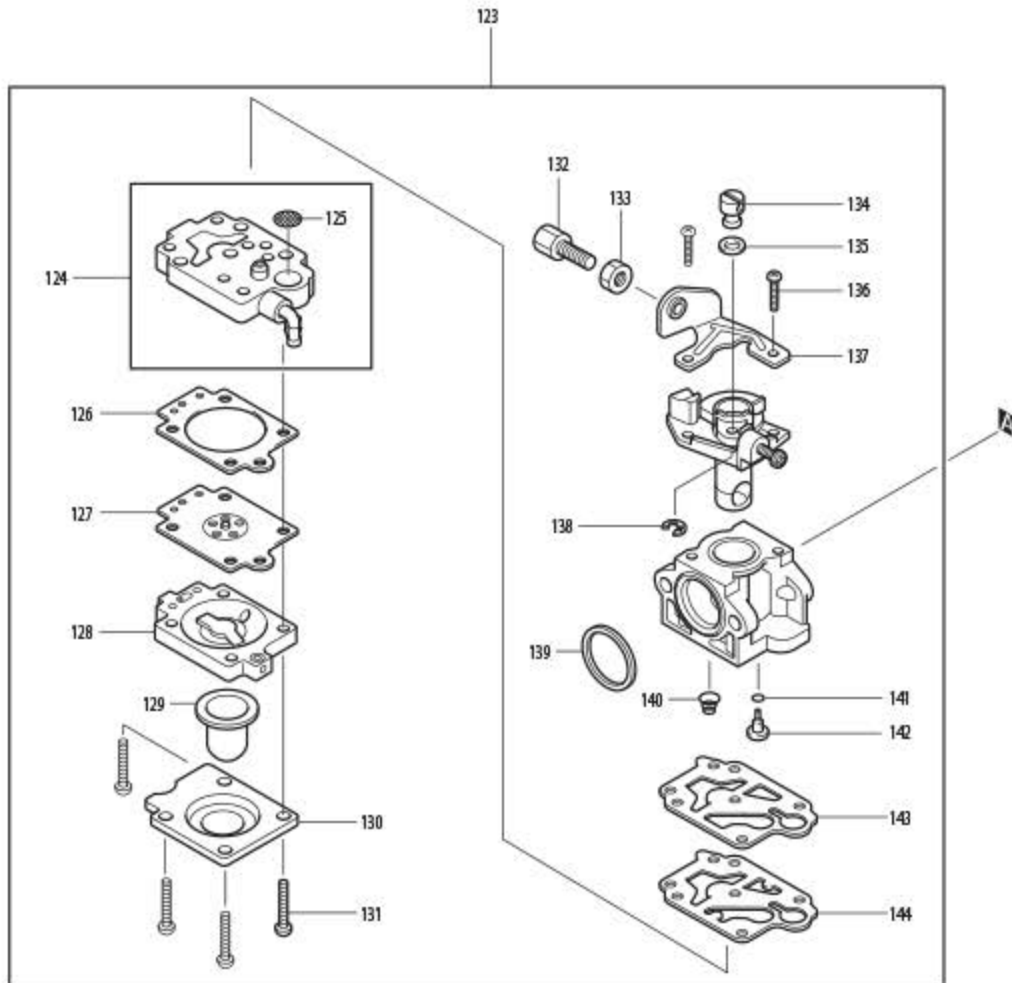

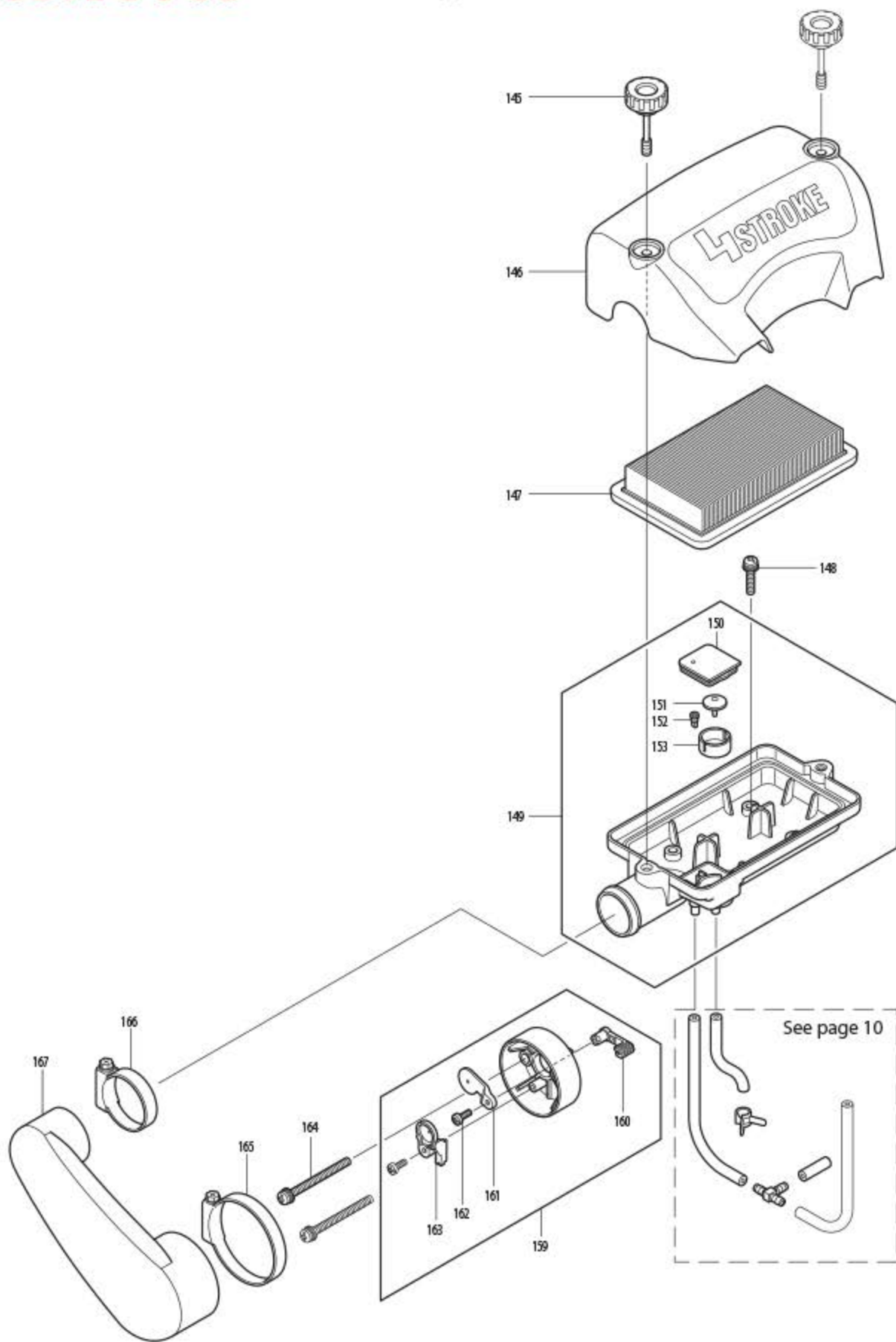

Reference Service Note
SN19.

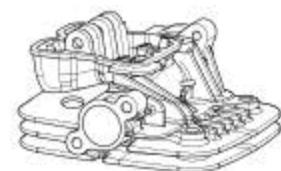
TYPE 1

Oil return passage here.

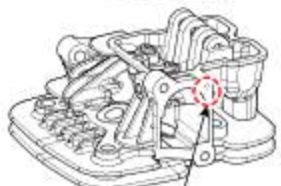
**TYPE 2 (Page 11)**

modified

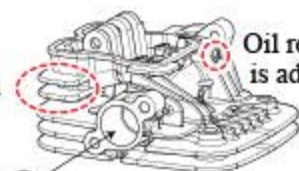

Oil return passage is added here.

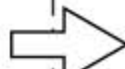

(Spacer Fig No. 199)

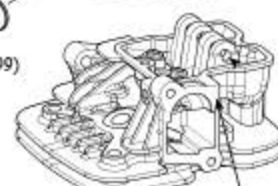

Oil return passage is eliminated.

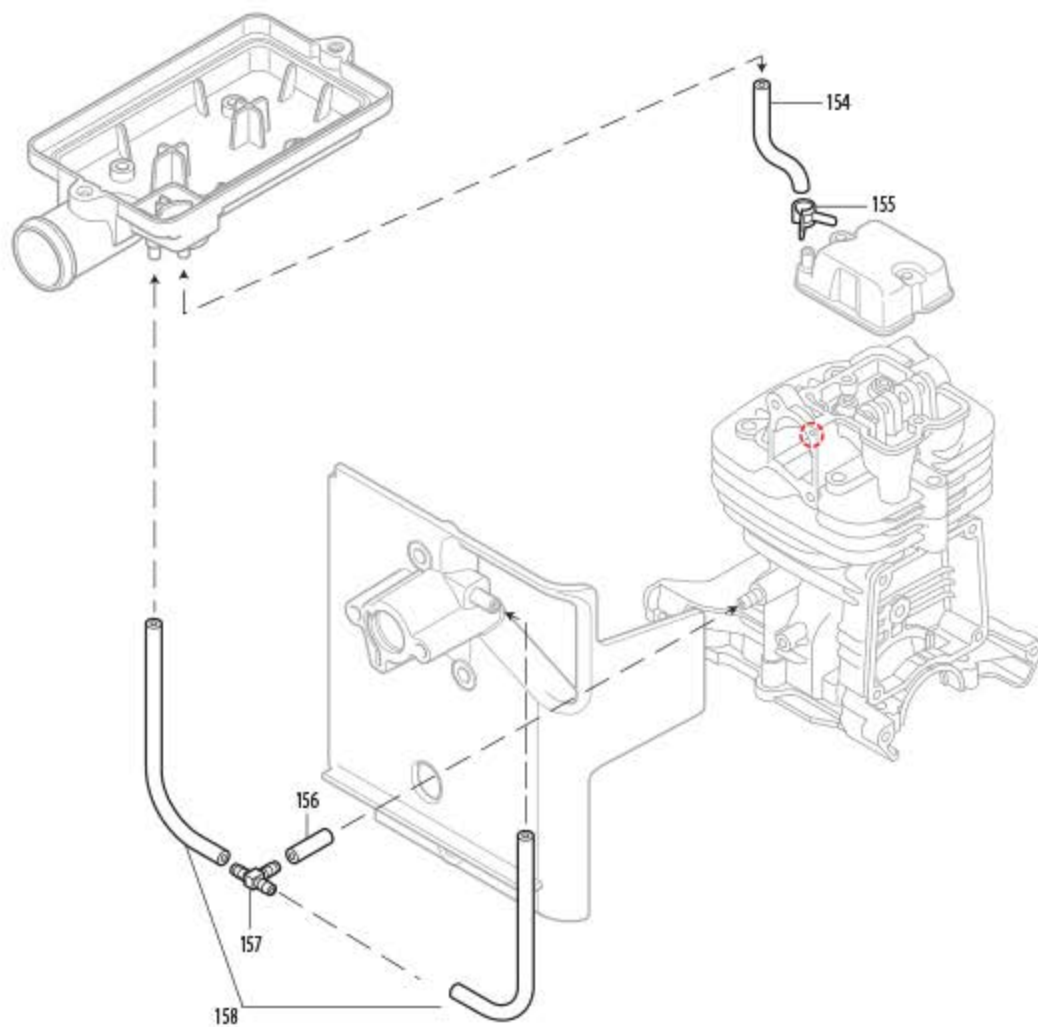
TYPE 1 - OIL TUBE ASSEMBLY

TYPE 2 - OIL TUBE ASSEMBLY