

861

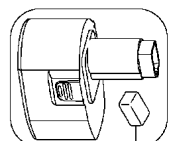

867
866

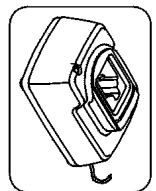

871

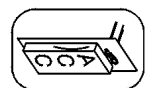

856

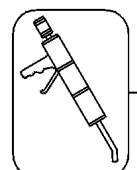

800

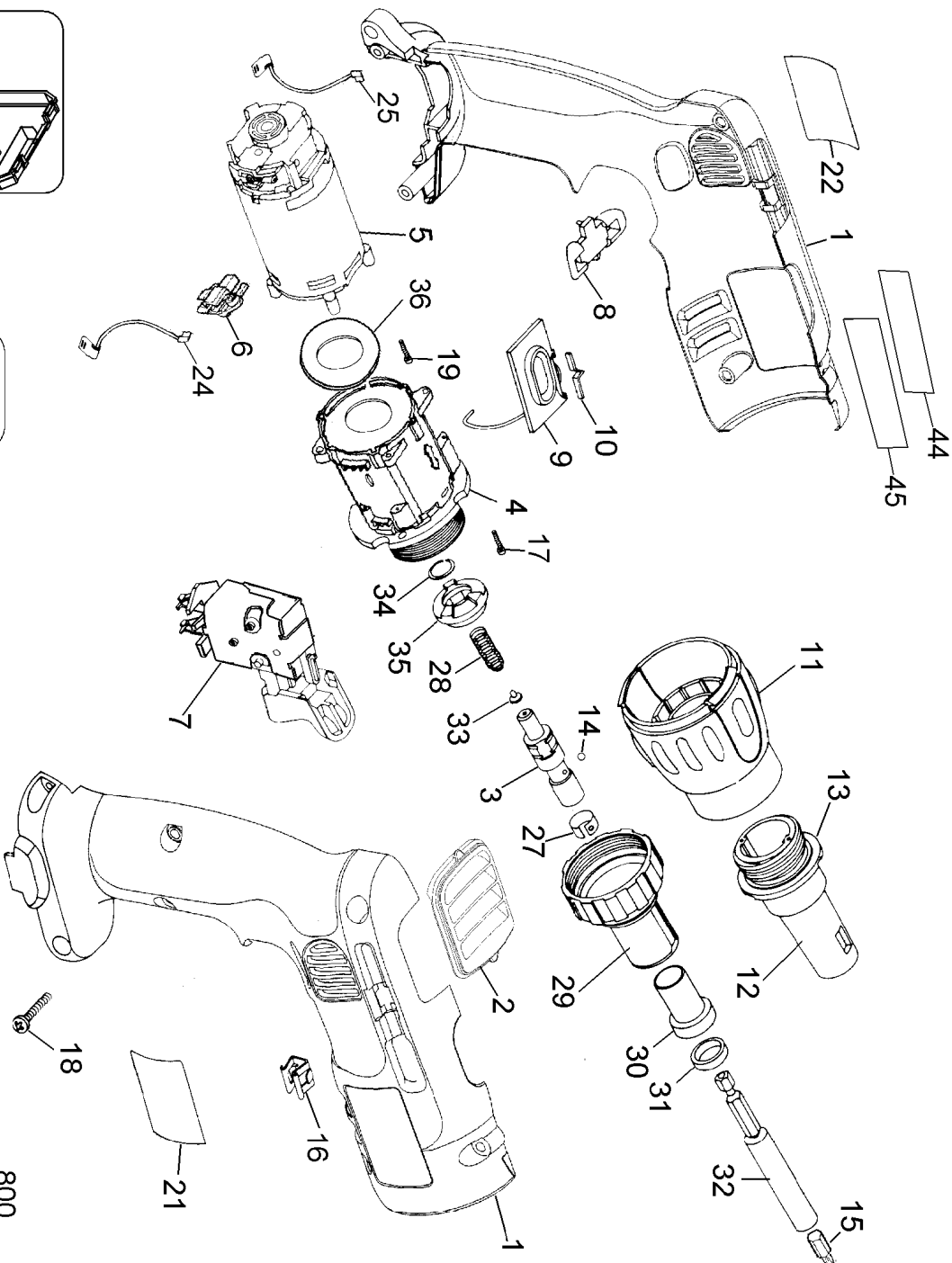

Parts List for DC520KA Type 1

Item Number	Part Number	Description	Qty Required
1	151791-20	CLAMSHELL SET	1
2	151681-00	VENT,AIR	1
3	096540-01	SPINDLE	1
4	152576-00SV	TRANSMISSION	1
5	606004-11SV	MOTOR & PINION	1
6	603754-01	BRUSH BOX	2
7	152274-19SV	SWITCH- V.S.R.	1
8	151678-00	BUTTON,FWD/REV	1
9	150939-01	SHIFTER	1
10	144658-00	SPRING	1
11	151225-00	COLLAR ADJUST	1
12	450770-01SV	LOCATOR	1
12	448862-00	LOCATOR	1
13	449890-00	SEAL,DUST	1
14	696631-00	BALL	1
15	607904-22	BIT,SCREWDRIVER	2
16	148354-03	BIT CLIP	2
17	330019-00	SCREW	4
18	330013-04	SCREW	7
19	098091-10	SCREW	4
21	624824-00	NAMEPLATE	1
22	395657-00	ID LABEL	1
24	389042-00	LEADWIRE,RED	1
25	389041-00	LEADWIRE,BLACK	1
27	094518-00	RETAINER	1
28	86211-00	SPRING	1
29	448859-05	CLUTCH HOUSING	1

COPYRIGHT© 2005. All Rights Reserved.

Parts list, pricing, and availability subject to change. Please visit www.dewaltservicenet.com for current parts information.

Parts List for DC520KA Type 1

Item Number	Part Number	Description	Qty Required
30	450907-00	BEARING,SLEEVE	1
31	696534-00	SEAL	1
32	619773-02	BIT TIP HOLDER	1
33	021287-00	GUIDE	1
34	089210-00	RET RING	1
35	603478-00	CLUTCH	1
36	152482-00	SEAL,FOAM	1
44	625597-00	WARNING LABEL	1
45	625598-00	WARNING LABEL	1
800	284778-00	GREASE,MOLYKOTE	1
856	364262-04	MAGNETIC NUTSETTER,5/16IN	1
856	DW2222	5/16 MAG SOCKET DRV	1
861	660141-00	KITBOX	1
866	DC9096	BATTERY PACK	2
867	645221-00	BATTERY CAP	2
871	388683-12	1 HOUR CHARGER	1

COPYRIGHT© 2005. All Rights Reserved.

Parts list, pricing, and availability subject to change. Please visit www.dewaltservicenetwork.com for current parts information.