

1) FUEL TANK, TUBULAR GRIP

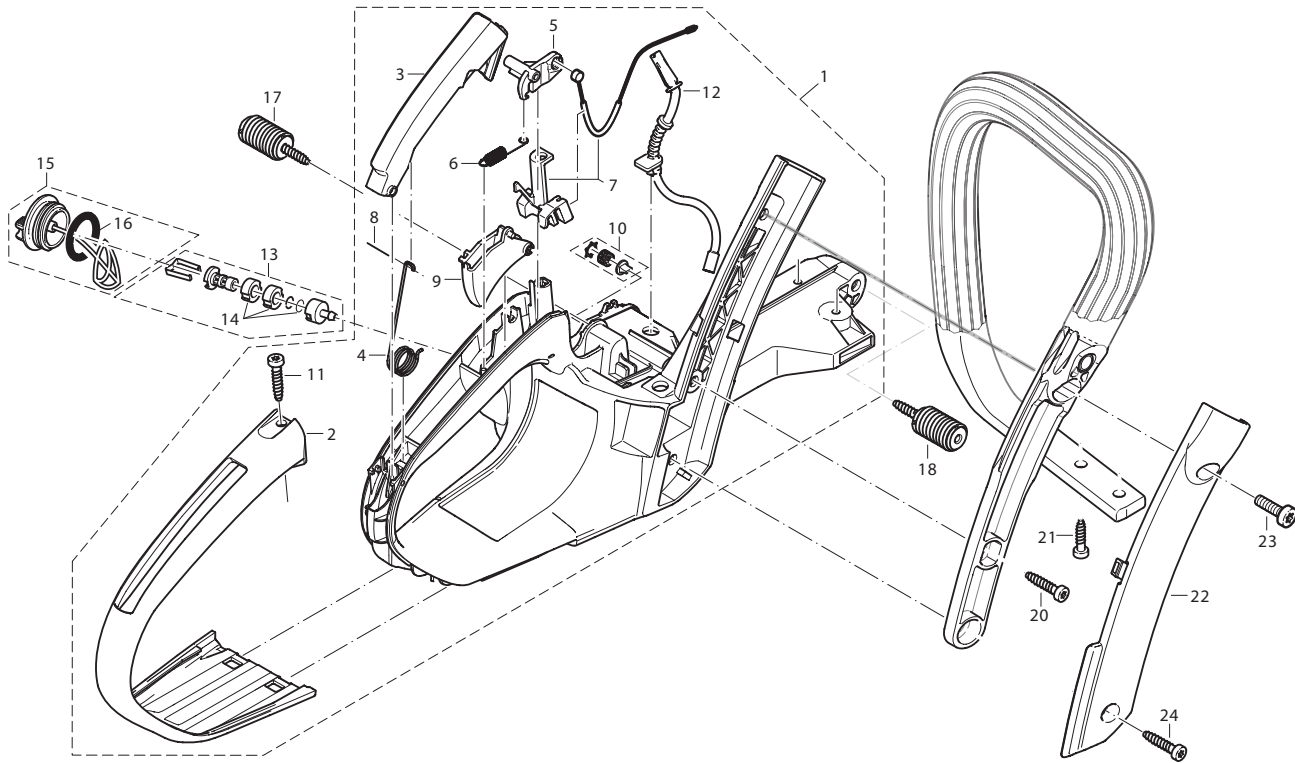

2a) HOOD, AIR FILTER, MUFFLER

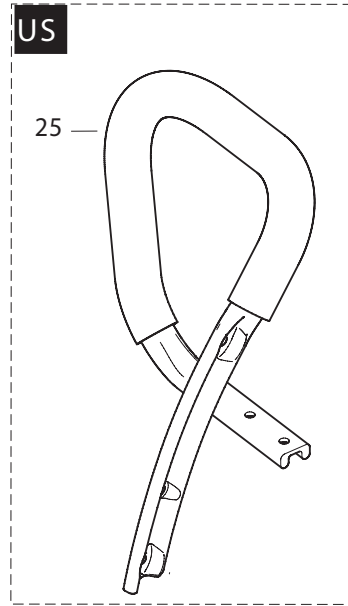
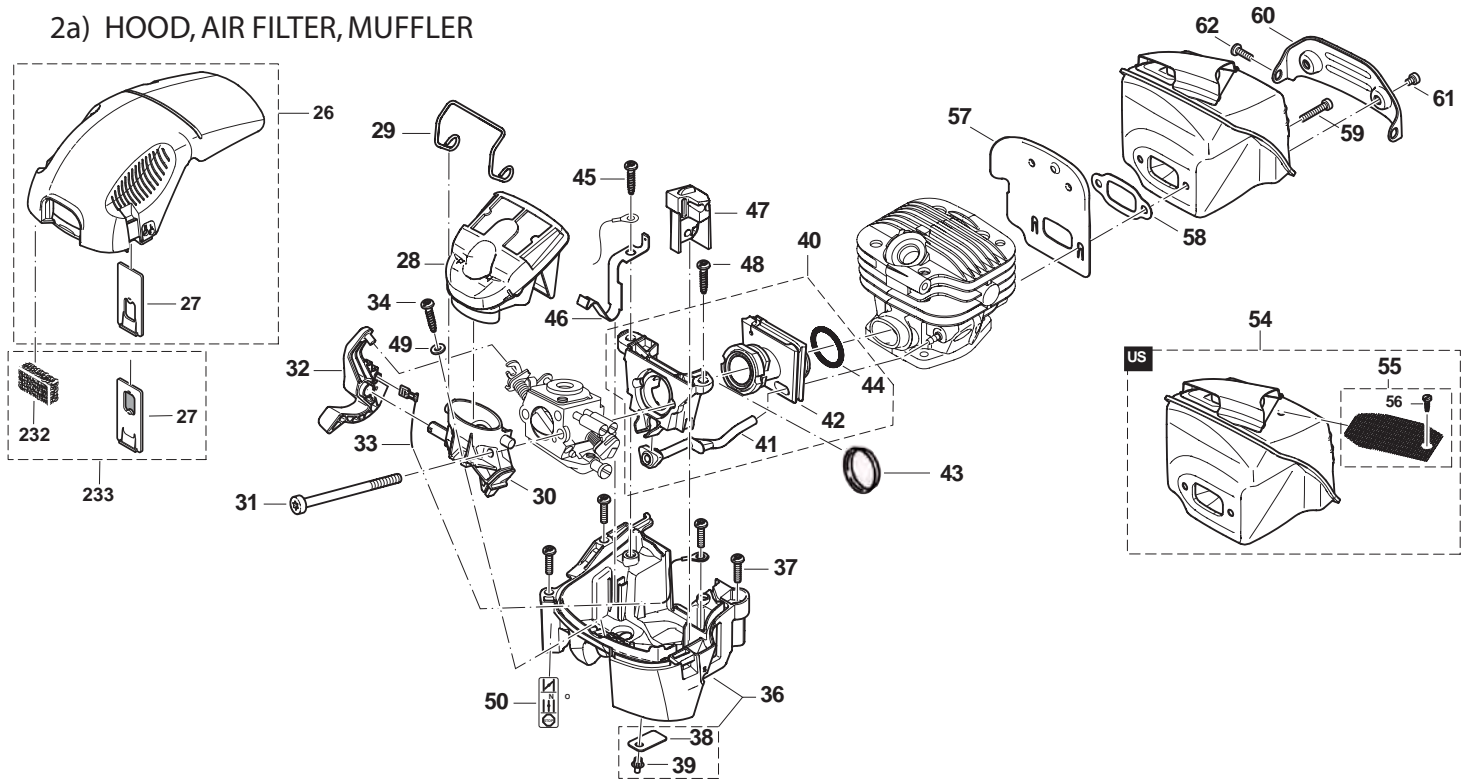

2b) CYLINDER CRANKCASE

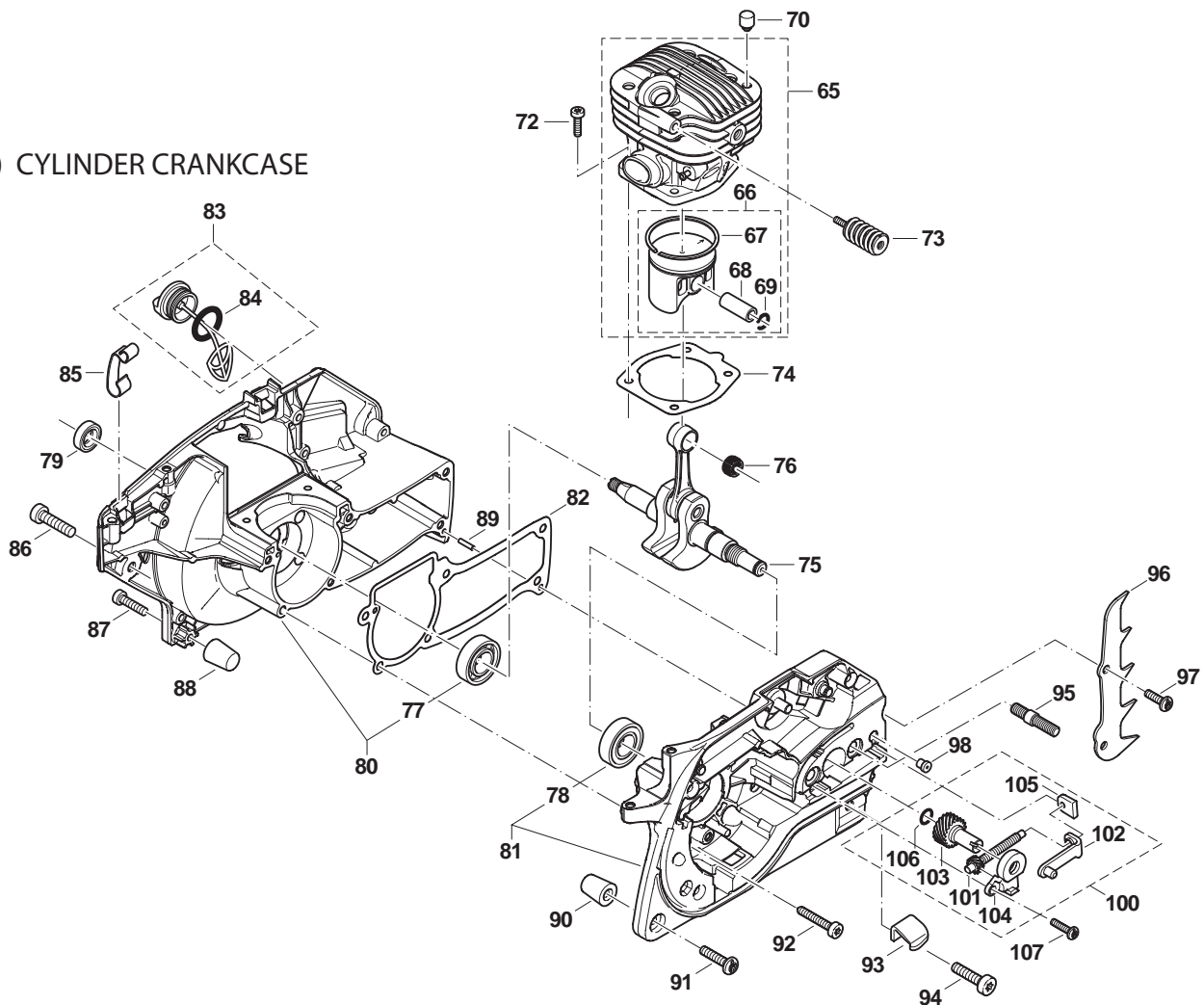

3a) IGNITION ELECTRONICS, STARTER

**Tech Bulletin 2010-01**

Easy Start - Implemented 2010 Production

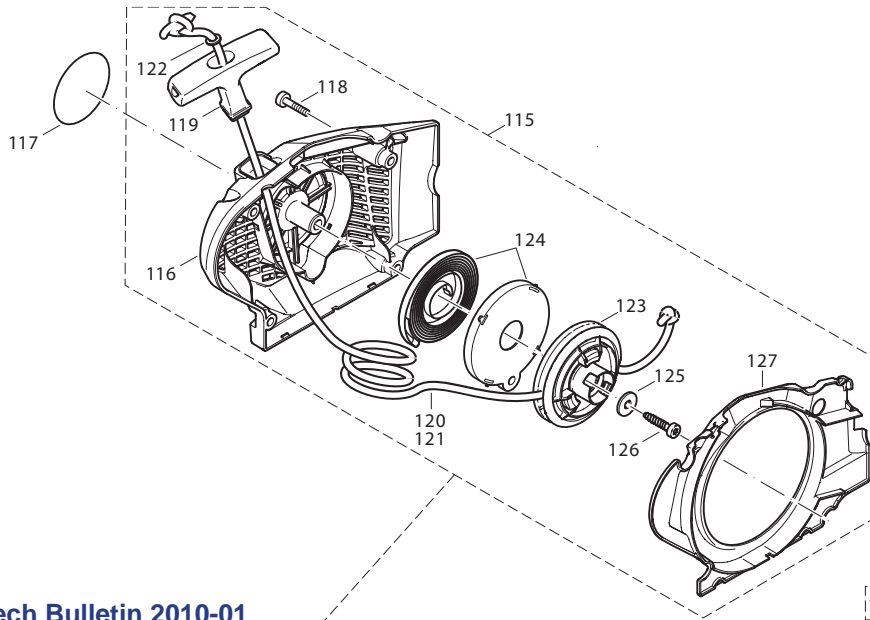
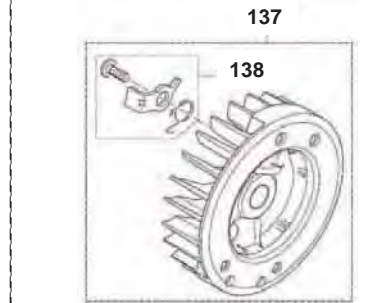

**Tech Bulletin 2010-01**

Easy Start - Implemented 2010 Production

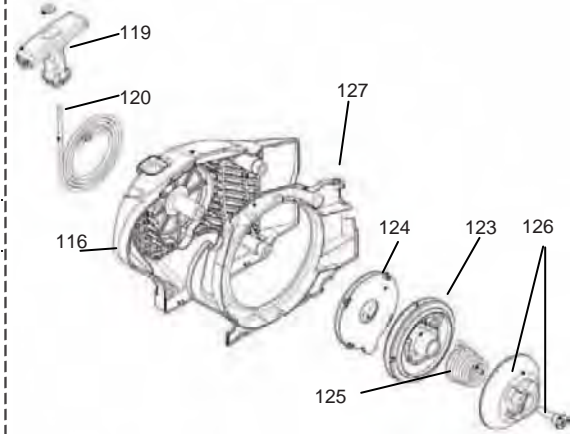

**Tech Bulletin 2010-01**

Easy Start - Implemented 2010 Production

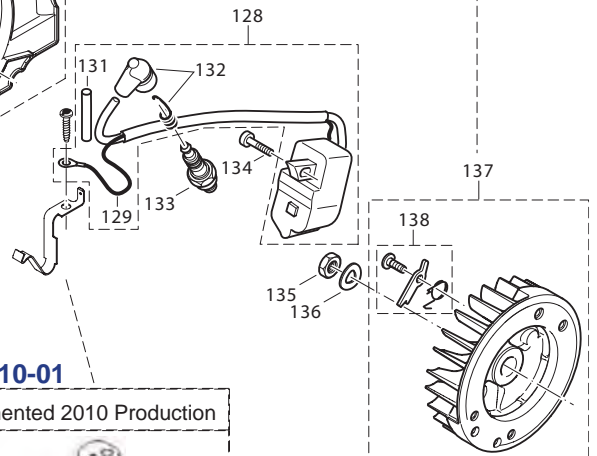
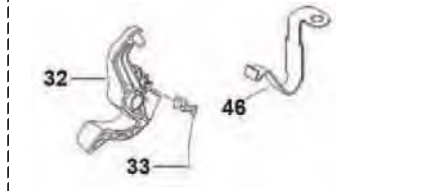

3b) OIL PUMP, CLUTCH, CHAIN BRAKE

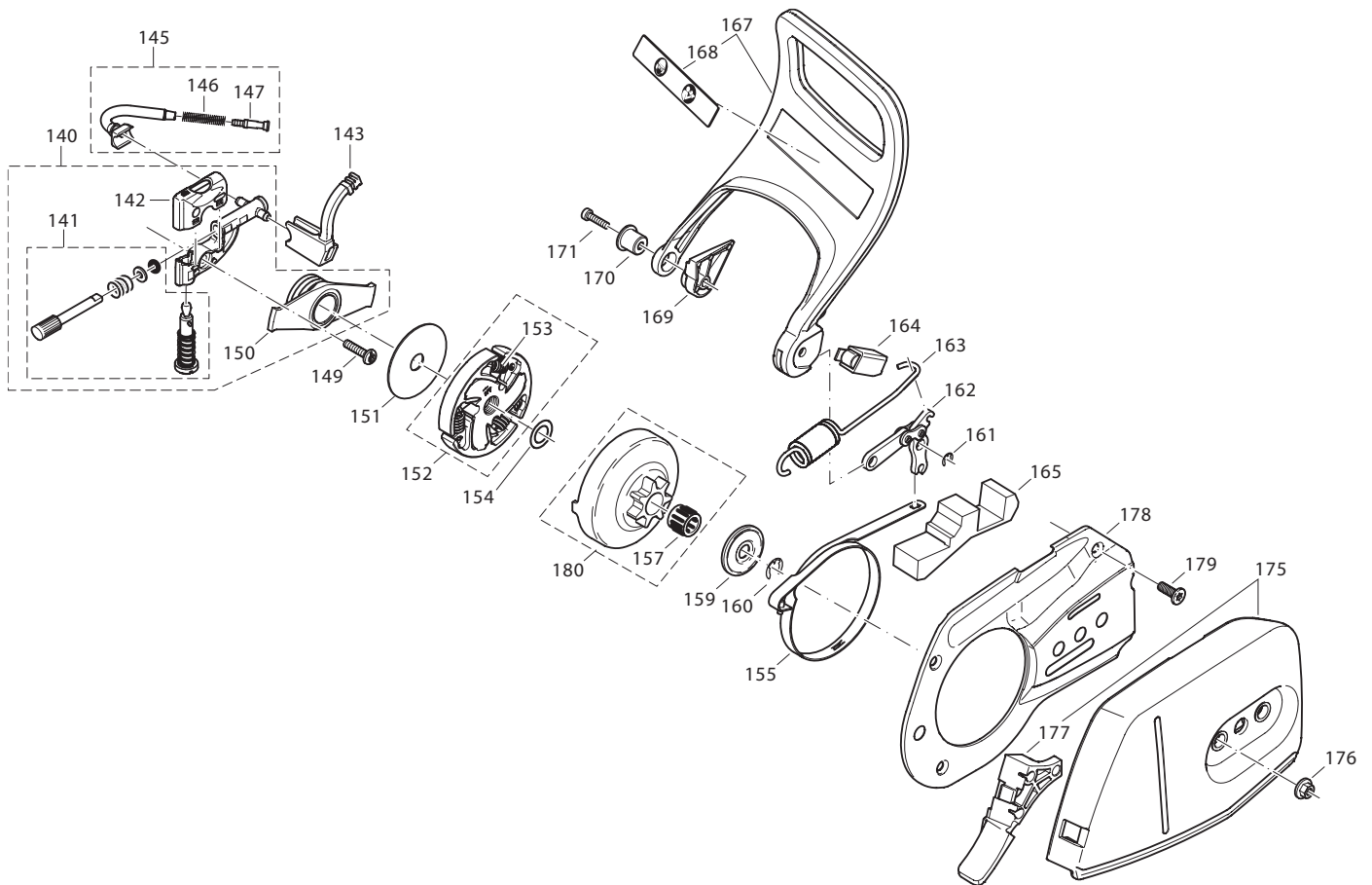

4) CARBURATOR

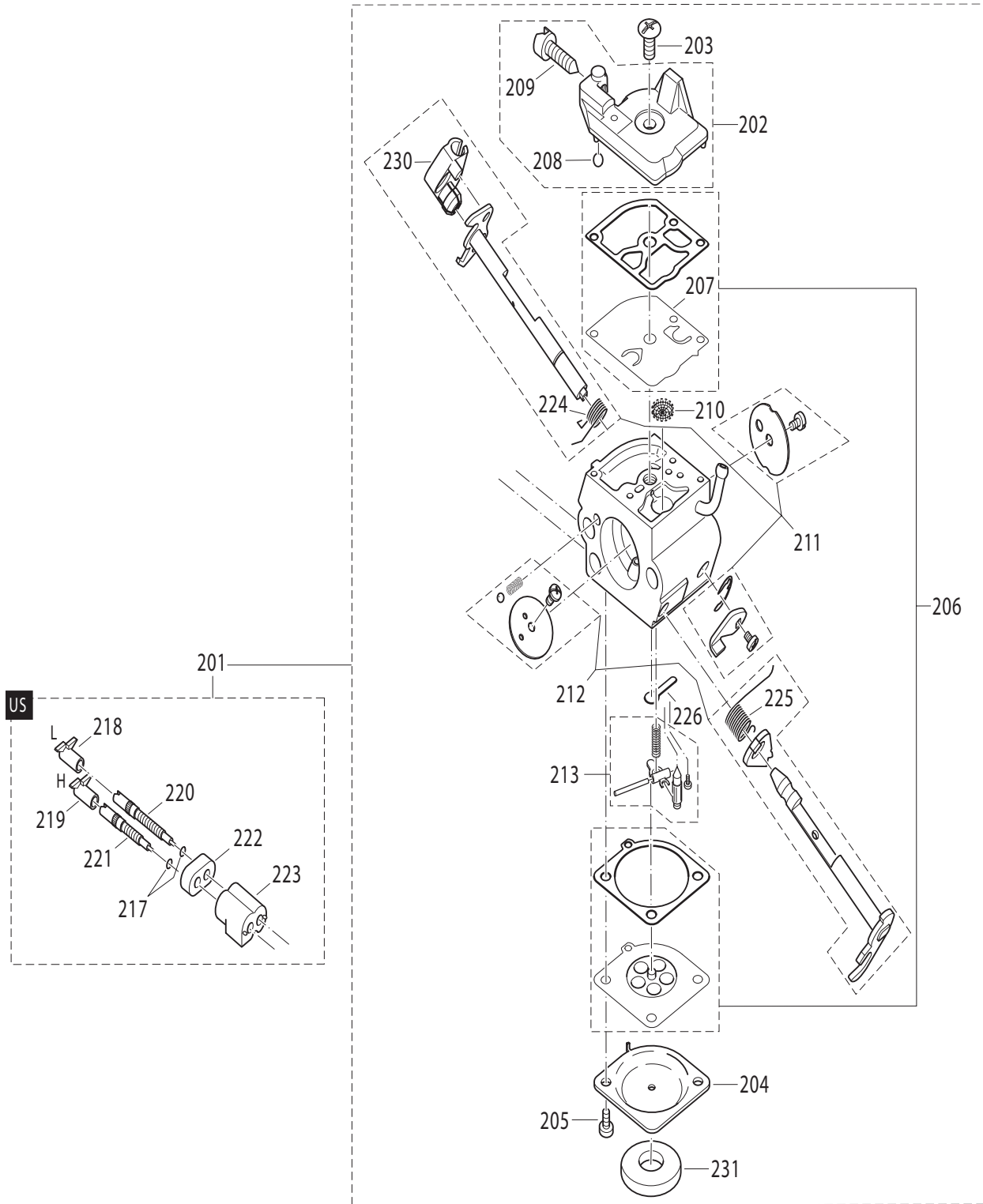

5) GUIDE BAR, SAW CHAINS, TOOLS

