

SERVICE CHANGE

1. Change on Tool Retainer and Tool Holder.

Type 1

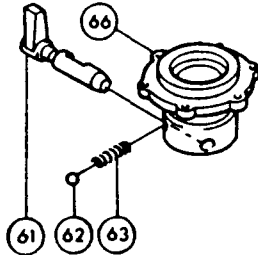

Type 2

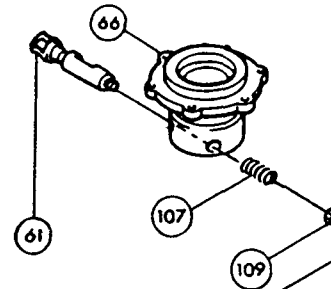

When tightening Nut,
apply metal adhesive

Fig.	Description	Type 1	Type 2
61	Tool Retainer	Part #314018-8	Part #322166-9
62	Steel Ball 7.9	Part #216004-4	(Discontinued)
63	Compression Spring	Part #231032-8	(Discontinued)
66	Tool Holder	Part #321830-9	Part #322167-7
107	Compression Spring	—————	Part #231281-7
109	HEX NUT M8-13	—————	Part #252046-4

• SEE SERVICE CHANGE 5

The above parts are completely interchangeable as a set.

2. Changes to Grip and Split Pin.

Type 1

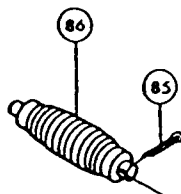

Hole has 4mm diameter

Type 2

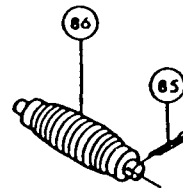

Hole has 3mm diameter

Bend Split Pin
as shown

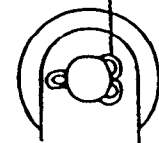

Fig.	Description	Type 1	Type 2
85	Split Pin	Part #952307-9 4-25	Part #952257-8 3-20
86	Grip 38	Part #273417-2 (Discontinued)	Part #273490-2

The above parts are completely interchangeable as a set.

3) Change on Seal Holder.

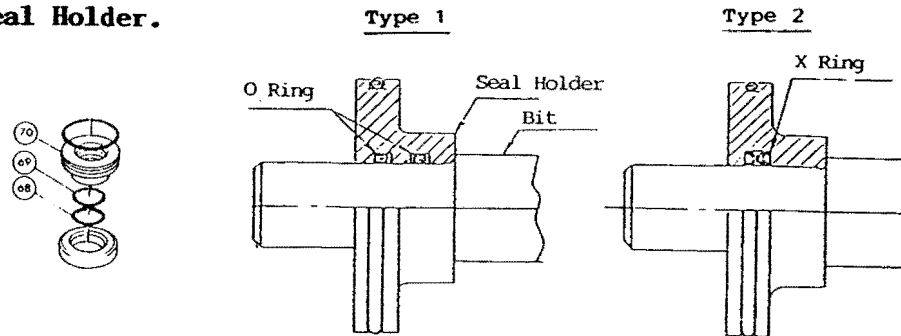

Fig.	Description	Type 1	Type 2
68	O Ring	Part #213372-6	Part #213383-1
69	O Ring	Part #213372-6	X Ring 25
70	Seal Holder	Part #321827-8 (Discontinued)	Part #322343-3

The above parts are completely interchangeable as a set.

4) Change on Hex Socket Head Bolts.

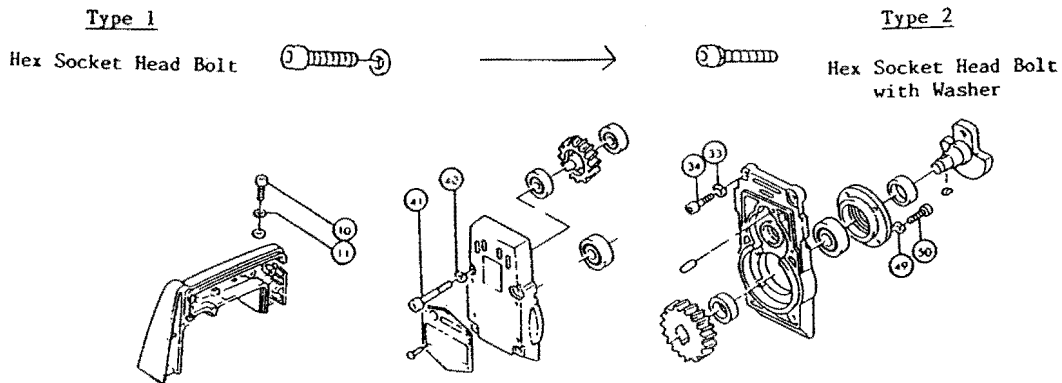

Fig.	Description	Type 1	Type 2	New Fig.	Qty.
10	Hex Socket Head Bolt M6X30	922352-8	922351-0	Fig. 10	4
11	Spring Washer 6	942151-2	with Washer		
33	Spring Washer 6	942151-2	922341-3	Fig. 34	2
34	Hex Socket Head Bolt M6X25	922342-1	with Washer		
40	Spring Washer 6	942151-2	922381-1	Fig. 41	4
41	Hex Socket Head Bolt M6X60	922382-9	with Washer		
49	Spring Washer 6	942151-2	922326-9	Fig. 50	4
50	Hex Socket Head Bolt M6X18	922327-7	with Washer		

5) Change on Tool Retainer from S/N 24,038E.

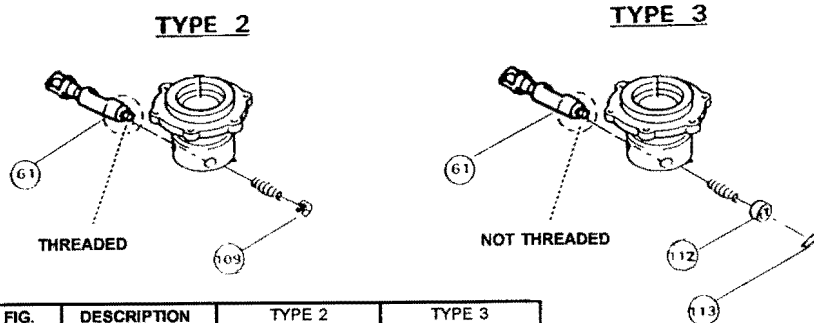

FIG.	DESCRIPTION	TYPE 2	TYPE 3
61	Tool Retainer	Part #322166-9 (Discontinued)	Part #322567-1
109	Hex Nut M8-13	Part #252046-4	---
112	Retaining Ring	---	Part #322699-4
113	Pin 4	---	Part #256219-1

The above parts are interchangeable as a set.